

Proposal Basic Information

Proposal File No.	JNP/IB/0002/W26/2023
Owner Name	KAUSHALYA DEVI
Khata No	9
Plot No	33
Village Name	Belatar
Use	Residential
SubUse	Bungalow/ Dwelling / Non Apartment

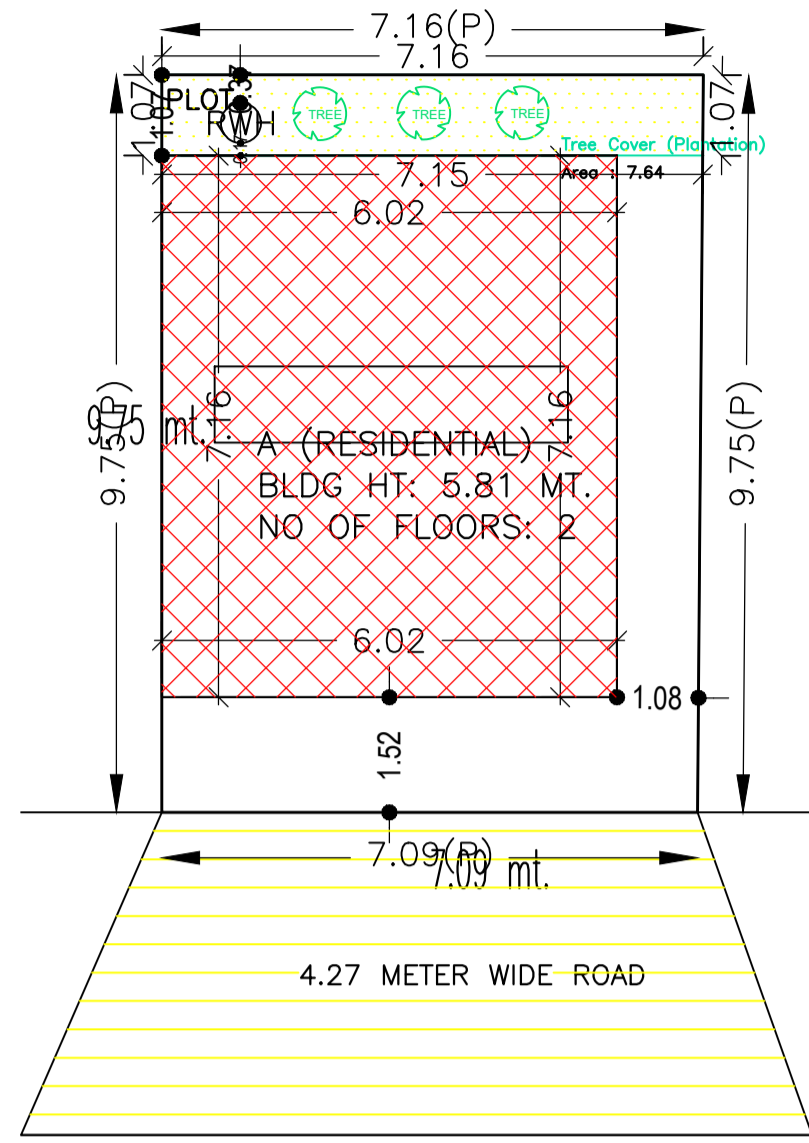

SITE PLAN

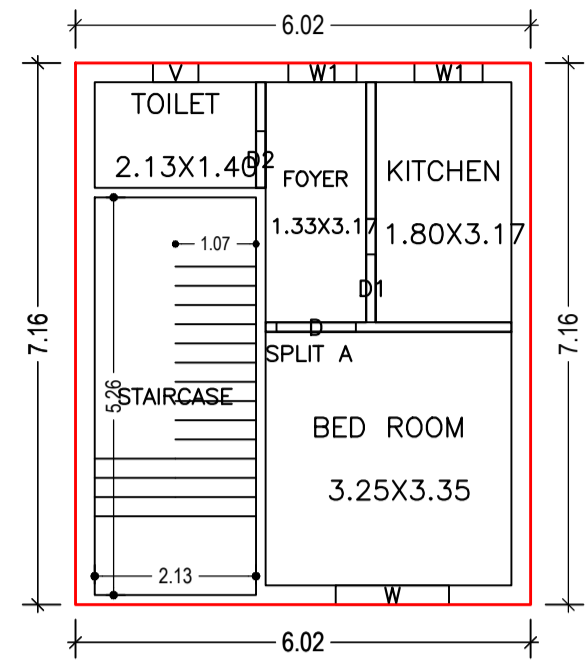

GROUND FLOOR PLAN (Proposed) (SCALE 1:100)

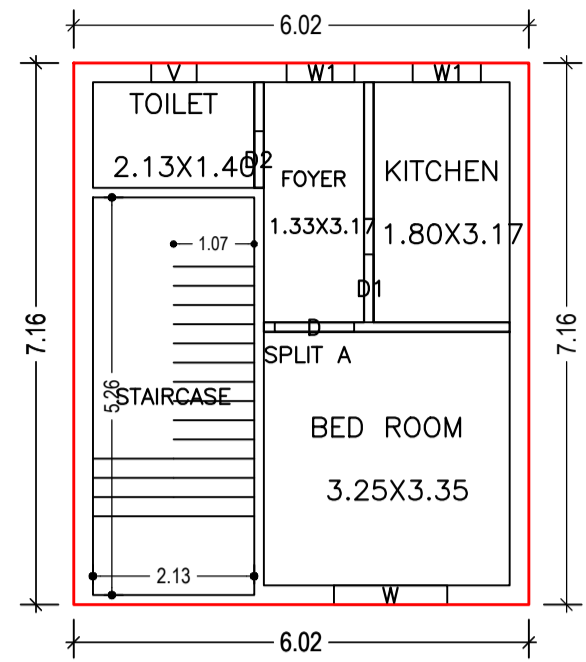

FIRST FLOOR PLAN (Proposed) (SCALE 1:100)

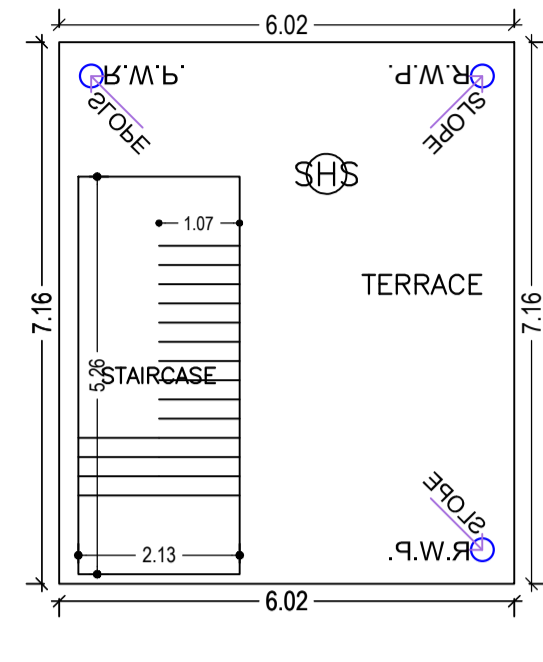

TERRACE FLOOR PLAN (SCALE 1:100)

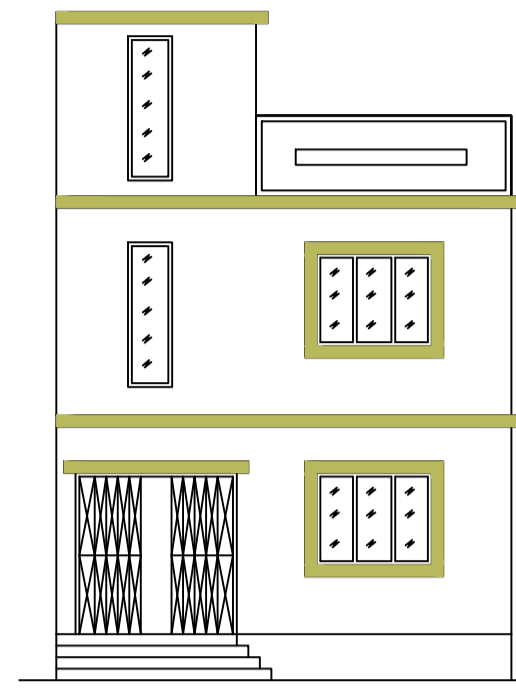

FRONT ELEVATION

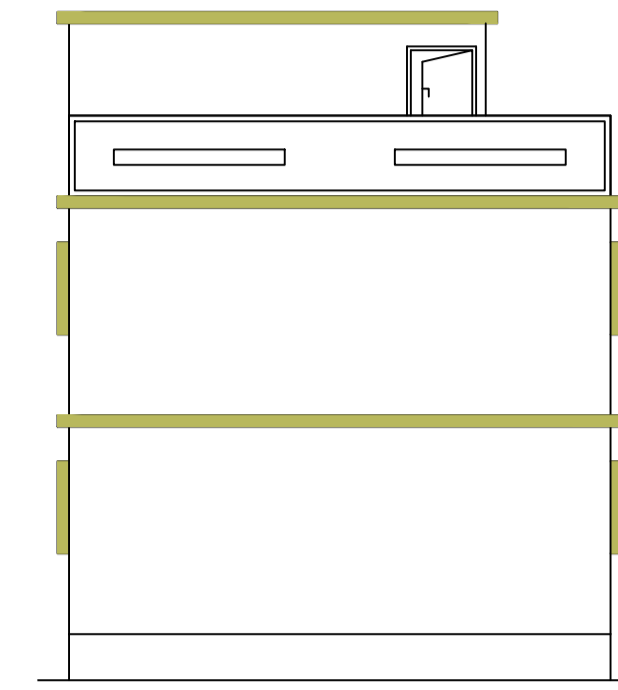

CROSS ELEVATION

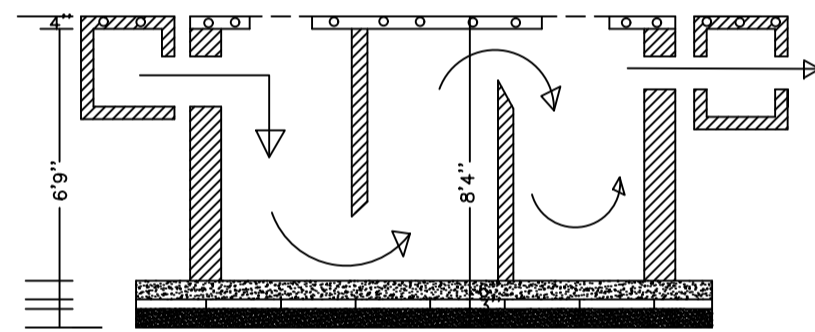

SECTION

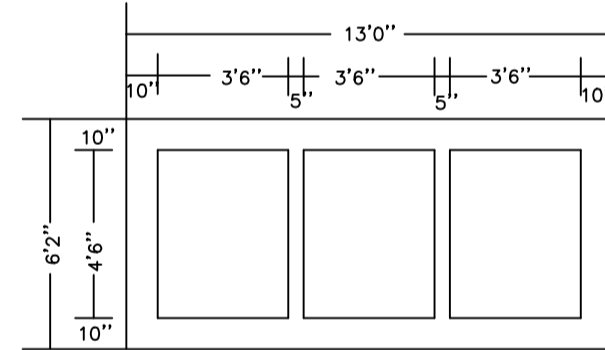

PLAN OF SEPTIK TANK

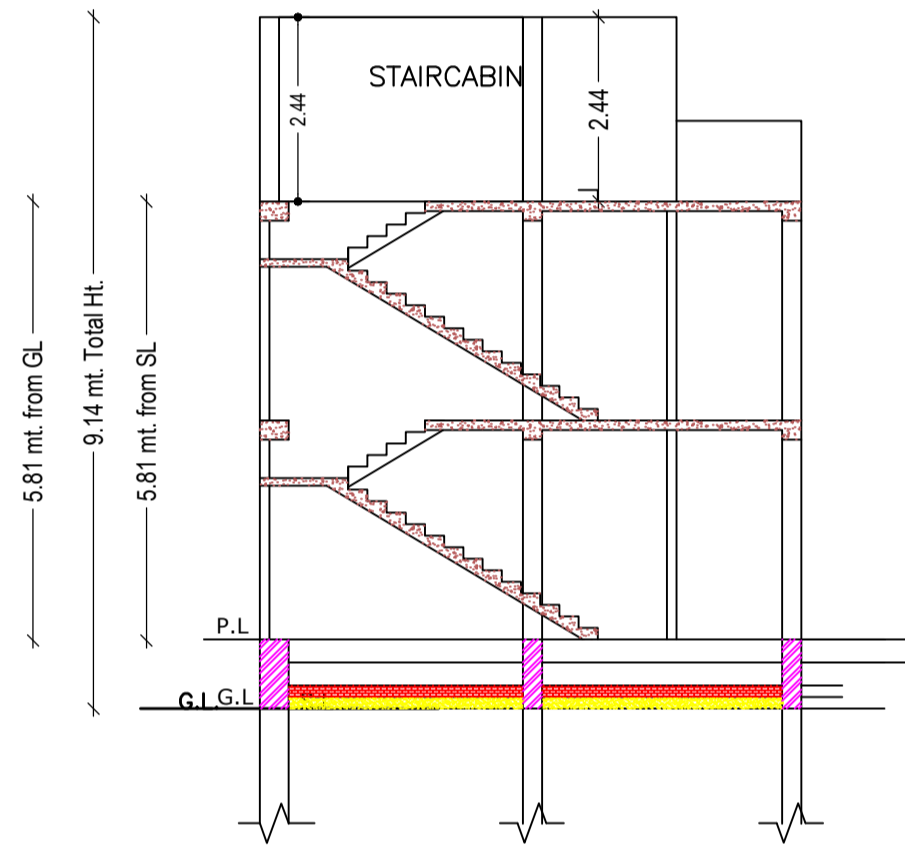

CROSS SECTION (A)

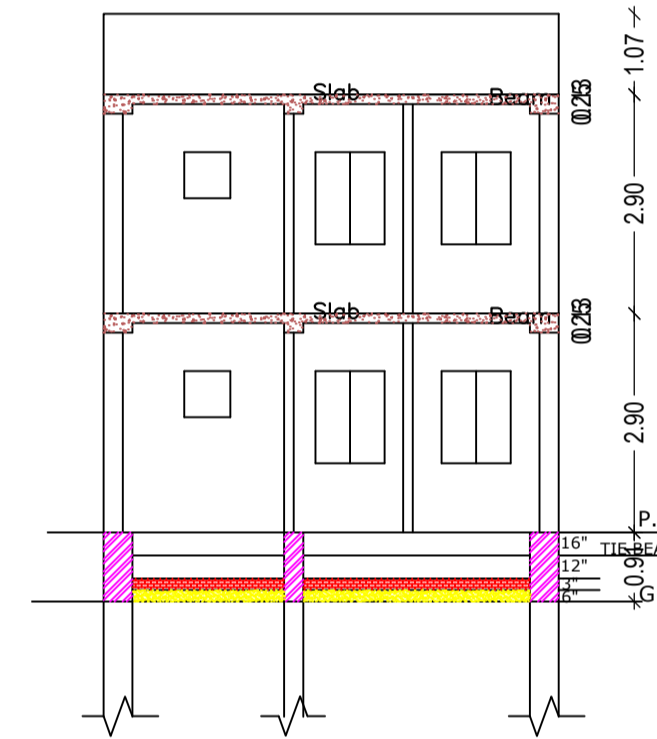

CROSS SECTION (B)

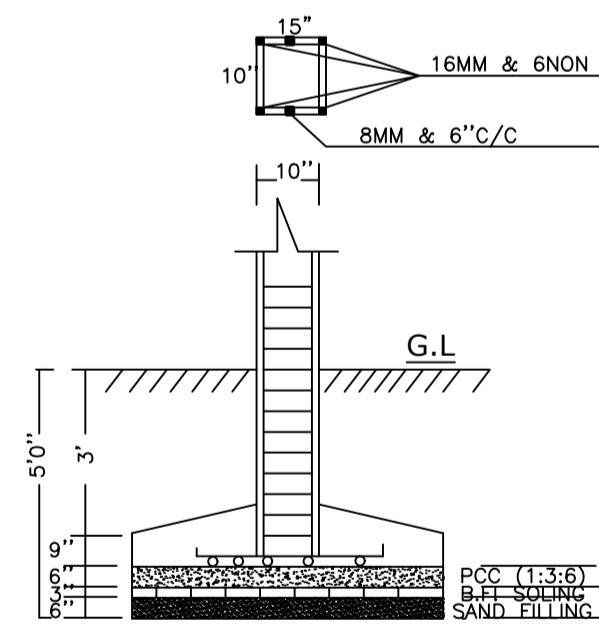

SECTION

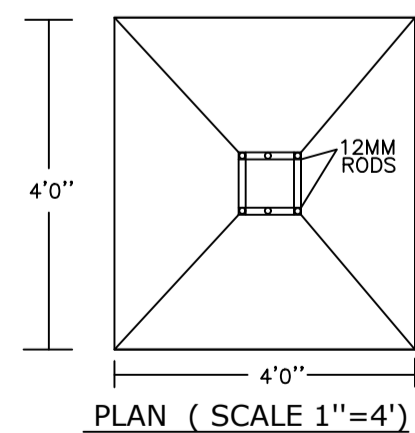

PLAN (SCALE 1"=4')

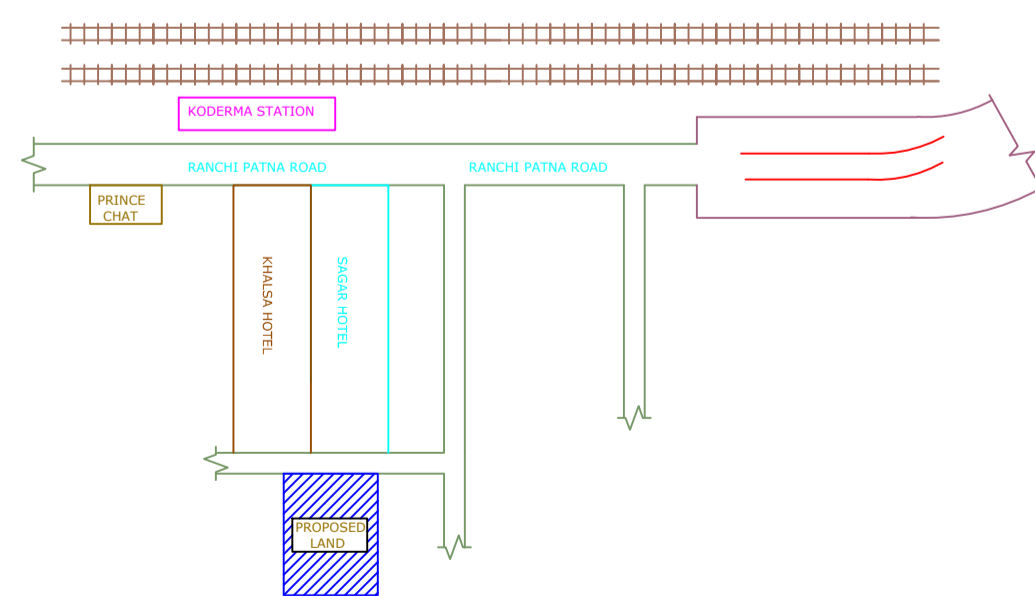

LOCATION PLAN (SCALE -1"=16')

AREA STATEMENT	VERSION NO.: 1.0.66	SQ.MT.
JHUMRITILAYA NAGAR PARISHAD	VERSION DATE: 16/10/2020	
PROJECT DETAIL:		
Region: JHARKHAND URBAN LOCAL BODIES	Plot Use: Residential	
District: KODERMA	Plot SubUse: Bungalow/ Dwelling / Non Apartment	
Authority: JHUMRITILAYA NAGAR PARISHAD	PlotNearby/ReligiousStructure: NA	
Inward No: JNP/IB/0002/W26/2023	Plot/SubPlot No: 33	
Application Type: General Proposal	North: Road Width - 4.27	
Project Type: Building Permission	South: Plot No. - HOUSE OF VAISHALI PRESS	
Nature of Development: New	East: Plot No. - NU VENDOR	
Location of Development Area: Old Area	West: Plot No. - NU VENDOR	
AREA DETAILS:		
AREA OF PLOT (Minimum)	(A)	69.49
NET AREA OF PLOT(Gross Plot Area - Deduction from Gross Plot area)	(A-Deductions)	69.49
Deduction for Balance Plot Area(from Gross Plot Area)		
Common Plot		7.64
Total		7.64
BALANCE AREA OF PLOT(Net Plot Area - Recreational/Amenity space)	(A-Deductions)	61.85
PLOT AREA FOR COVERAGE(Net Plot Area)	(A-Deductions)	69.49
Plot Area for FAR (Net Plot Area + Road/Widening Area)	(A-Deductions)	69.49
COVERAGE CHECK		
Permissible Coverage area ( 70.00 % )		48.64
Proposed Coverage Area ( 62.05 % )		43.12
Total Prop. Coverage Area ( 62.05 % )		43.12
Balance coverage area ( 7.94 % )		5.52
FAR CHECK		
Perm. FAR Area ( 1.500 )		104.24
Total Perm. FAR area		104.24
Residential FAR		86.24
Proposed FAR Area		86.24
Total Proposed FAR Area		86.24
Consumed FAR (Factor)		1.24
Balance FAR Area		18.00
BUILT UP AREA CHECK		
Total Proposed BuiltUp Area		86.24
ARCHITECT (Regd)	KIRAN KUMARI	
ENGINEER (Regd)		
SUPERVISOR (Regd)		
OWNER (Regd)	KAUSHALYA DEVI	
DEVELOPMENT AUTHORITY		LOCAL BODY

Buildingwise Floor FAR Details

Floor Name	Building Name		Total	
	Proposed Built Up Area (Sq.mt.)	Proposed FAR Area (Sq.mt.)	Total Proposed Built Up Area (Sq.mt.)	Total FAR Area (Sq.mt.)
Ground Floor	43.12	43.12	43.12	43.12
First Floor	43.12	43.12	43.12	43.12
Terrace Floor	0.00	0.00	0.00	0.00
Total :	86.24	86.24	86.24	86.24

Building USE/SUBUSE Details

Building Name	Building Use	Building SubUse	Building Structure
A (RESIDENTIAL)	Residential	Bungalow/ Dwelling / Non Apartment	Non-Highrise

FAR & Tenement Details (Table 4c-1)

Building	No. of Same Bldg	Total Built Up Area (Sq.mt.)	Proposed FAR Area (Sq.mt.)	Total FAR Area (Sq.mt.)	Total Consumed Additional FAR Area (Sq.mt.)	Tnmt (No.)
A (RESIDENTIAL)	1	86.24	86.24	86.24	86.24	01
Grand Total :	1	86.24	86.24	86.24	86.24	01

UnitBUA Table for Building :A (RESIDENTIAL)

FLOOR	Name	UnitBUA Type	UnitBUA Area	Carpet Area	No. of Rooms	No. of Tenement
GROUND FLOOR PLAN	SPLIT A	FLAT	49.59	47.60	4	1
FIRST FLOOR PLAN	SPLIT A	FLAT	0.00	0.00	4	0
Total:	-	-	49.59	47.60	8	1

SCHEDULE OF DOOR:

BUILDING NAME	NAME	LENGTH	HEIGHT	NOS
A (RESIDENTIAL)	D2	0.75	2.10	02
A (RESIDENTIAL)	D1	0.90	2.10	02
A (RESIDENTIAL)	D	1.05	2.10	02

SCHEDULE OF WINDOW/VENTILATION:

BUILDING NAME	NAME	LENGTH	HEIGHT	NOS
A (RESIDENTIAL)	V	0.60	0.90	02
A (RESIDENTIAL)	W1	0.90	1.20	04
A (RESIDENTIAL)	W	1.50	1.20	02

Building :A (RESIDENTIAL)

Floor Name	Total Built Up Area (Sq.mt.)	Proposed FAR Area (Sq.mt.)	Total FAR Area (Sq.mt.)	Total Consumed Additional FAR Area (Sq.mt.)	Tnmt (No.)
Ground Floor	43.12	43.12	43.12	43.12	01
First Floor	43.12	43.12	43.12	43.12	00
Terrace Floor	0.00	0.00	0.00	0.00	00
Total :	86.24	86.24	86.24	86.24	01
Total Number of Same Buildings :	1				
Total :	86.24	86.24	86.24	86.24	01

COLOR INDEX

PLOT BOUNDARY	Black
ABUTTING ROAD	Green
PROPOSED CONSTRUCTION	Red
COMMON PLOT	Yellow
ROAD WIDENING AREA	Blue
EXISTING (To be retained)	Light Blue
EXISTING (To be demolished)	Orange

LTP NAME AND SIGNATURE

KIRAN KUMARI  
JNP/ENG/001/2019

STRUCTURAL ENG'S NAME AND SIGNATURE

BUILDER NAME AND SIGNATURE

DIGITAL SIGNATURE