

Project Title : RAJEEV RANJAN

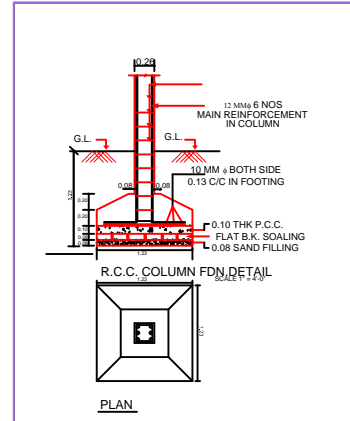

| AREA STATEMENT : RAJEEV RANJAN | | VERSION NO : 0.01 |
|---|--|--------------------------|
| PROJECT DETAIL | | VERSION DATE: 16/02/2024 |
| Plot No. | Plot Use: Residential | |
| Project Name: RAJEEV RANJAN LOCAL BODIES | Plot Location: Residential/Commercial/ New Apartment | |
| District: KODERMA | Land Use Zone: RA | |
| Application Type: General Proposal | Abutting Road Width: - | |
| Project Type: Building Permission | Site No.: | |
| Nature of Development: New | Revenue Survey No./Survey No.: | |
| Location: GID Area | Thana No.: | |
| Sub Location: RA | Warding No.: | |
| Village/Muza Name: - | Khasa No.: | |
| Block No.: | North.: | |
| Food Street: - | South.: | |
| | East.: | |
| | West.: | |
| AREA DETAILS | | IS:W/F |
| Net Plot Area (Minimum) | (A) | 100.51 |
| Net Plot Area (Gross Plot Area - (A-Deductions)) | | 100.51 |
| Deductions for Balance Plot Area (from Gross Plot Area) | | |
| TOP Area | | 12.28 |
| Total | | 12.28 |
| Balance Plot Area (Net Plot Area - (A-Deductions)) | | 87.64 |
| Plot Area for Coverage (Net Plot Area) | (A-Deductions) | 100.51 |
| Plot Area for FAR (Net Plot Area + Road/Widening Area) | (A-Deductions) | 100.51 |
| COVERAGE CHECK | | |
| Proposed Coverage Area (60.82 %) | | 61.13 |
| Max Coverage Area (60.82 %) | | 61.13 |
| FAR CHECK | | |
| Proposed Area of FAR | | 122.26 |
| Max Area of FAR | | 122.26 |
| BRUT TO FINISH CHECK | | |
| Total Proposed Built up Area | | 122.26 |
| ARCHT ENGRG / SUPERVISOR (Page) | | OWNER |
| DEVELOPMENT AUTHORITY | | LOCAL BODY |

| COLOR INDEX | | | | | |
|-------------------------------------|-------------------------|----------------------------|--------------------------|-----------------------|--------------|
| Color Index: | | | | | |
| MARGIN DETAIL: | | | | | |
| Building / W/M | Road Name | Front Margin | Rear Margin | Side Margin | Solid Margin |
| AA (AA) | 3.06 mt. Wide Main Road | 1.51 | 0.91 | 0.91 | 0.91 |
| FAR & Tenement Details (Table 4c-1) | | | | | |
| Building | No. of Same Bldg | Total Built Up Area (Sq.m) | Proposed FAR Area (Sq.m) | Total FAR Area (Sq.m) | Tenmt (No.) |
| AA (AA) | 1 | 122.26 | 122.26 | 122.26 | 01 |
| Grand Total | 1 | 122.26 | 122.26 | 122.26 | 01 |

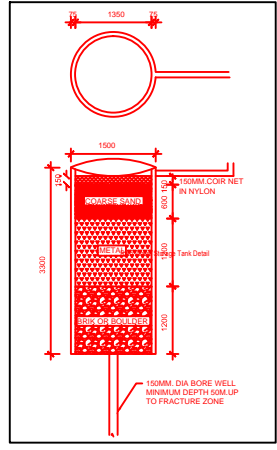
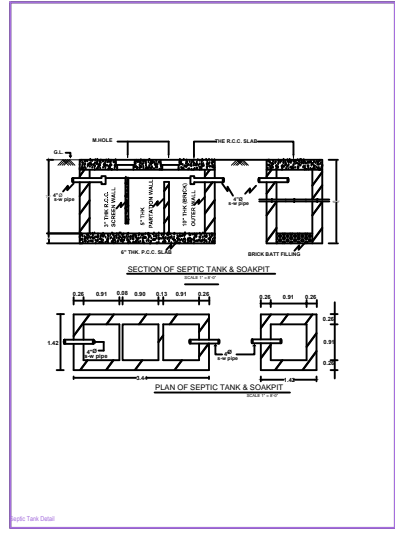
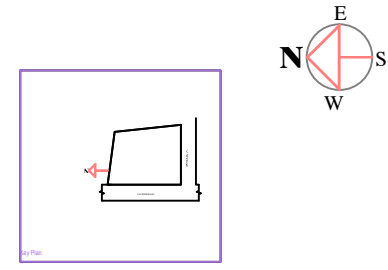
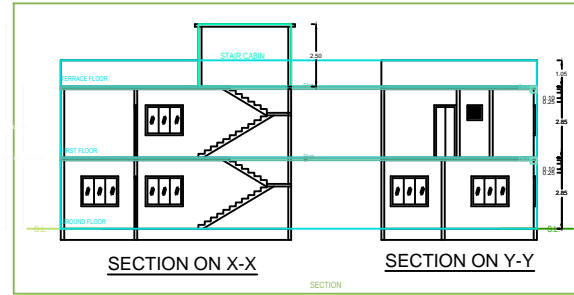
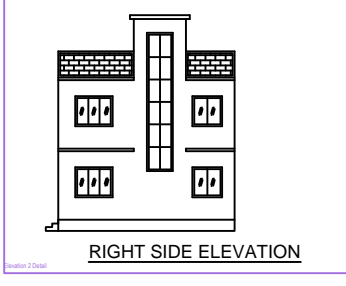
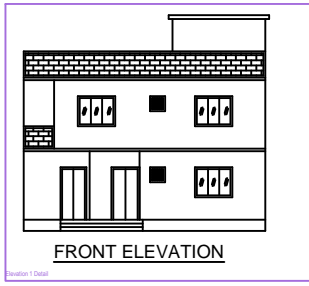
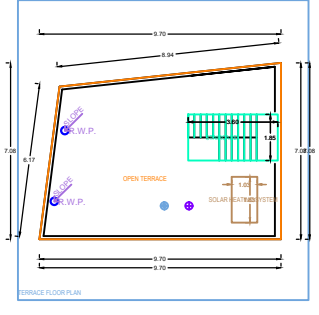
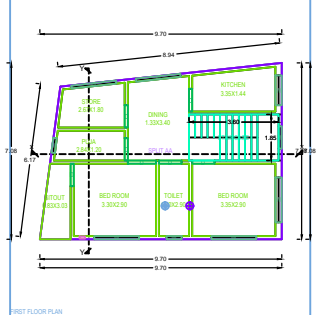
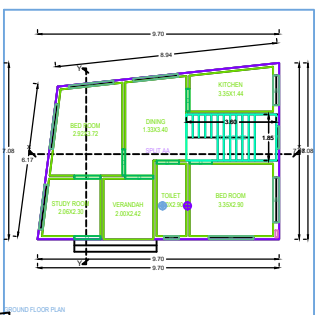
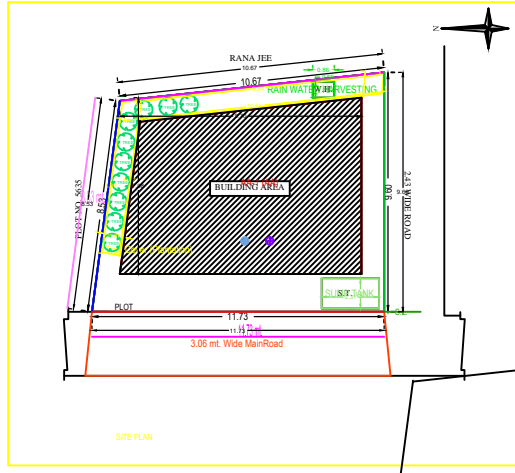

| Floor Name | Total Built Up Area (Sq.m) | Proposed FAR Area (Sq.m) | Total FAR Area (Sq.m) | Tenmt (No.) |
|---------------|----------------------------|--------------------------|-----------------------|-------------|
| Ground Floor | 61.13 | 61.13 | 61.13 | 01 |
| FIRST FLOOR | 61.13 | 61.13 | 61.13 | 01 |
| TERRACE FLOOR | 0.00 | 0.00 | 0.00 | 00 |
| Total | 122.26 | 122.26 | 122.26 | 01 |

| SCHEDULE OF JOINERY: | | | | |
|----------------------|------|--------|--------|-----|
| BUILDING NAME | NAME | LENGTH | HEIGHT | NOS |
| AA (AA) | D | 0.90 | 2.10 | 09 |
| AA (AA) | D | 1.20 | 2.10 | 03 |
| AA (AA) | D | 1.13 | 2.10 | 02 |
| Total | - | - | - | 14 |

| SCHEDULE OF JOINERY: | | | | |
|----------------------|------|--------|--------|-----|
| BUILDING NAME | NAME | LENGTH | HEIGHT | NOS |
| AA (AA) | W | 0.90 | 1.20 | 03 |
| AA (AA) | W | 0.90 | 1.20 | 02 |
| AA (AA) | W | 1.20 | 1.20 | 02 |
| AA (AA) | W | 1.80 | 1.20 | 11 |
| Total | - | - | - | 18 |

| Unit/BUA Table for Building 'AA (AA) | | | | | | |
|--------------------------------------|----------|---------------|---------------|---------------|--------------|-----------------|
| FLOOR | Name | UNIT/BUA Type | Unit/BUA Area | Carpet Area | No. of Rooms | No. of Tenement |
| GROUND FLOOR/PLAN | SPLIT AA | FLAT | 122.27 | 122.24 | 1 | 1 |
| Total | - | - | 122.27 | 122.24 | 1 | 1 |