

Project Title :1.SMT KULDEEP KAUR.W/O - SRI. TARANJEET SINGH. 2. SRI.TARANJEET SINGH. SO- SRI.HARBHAJAN SINGH.

AREA STATEMENT: JHUMRILAYANA NAGAR	VERSION NO.: 1.0.36
PARISHAD	VERSION DATE: 16/10/2020
PROJECT DETAIL:	
Plot No.:	Plot User: Residential
Region: JHARKHAND URBAN LOCAL BODIES	Plot SubUser: Bungalow Dwelling / Non Apartment
District: KODERMA	Land Use Zone: NA
Application Type: General Proposal	Abutting Road Width: -
Project Type: Building Permission	Plot No.:
Nature of Development: New	Revenue Survey No/Survey No: -
Location: Old Area	Thana No: -
Sub Location: NA	Holding No: -
Village/Mauza Name: -	Khata No: -
Ward No: -	North: -
Road/Street: -	South: -
	East: -
	West: -

AREA DETAILS		SQ.MT.
AREA OF PLOT (Minimum)	(A)	50.85
Net Plot Area (Gross Plot Area - Deduction from Gross Plot area)	(A-Deductions)	50.85
Deductions for Balance Plot Area (from Gross Plot Area)		
COP Area		6.21
Total		6.21
Balance Plot Area (Net Plot Area - Recreational/Amenity space)	(A-Deductions)	44.64
Plot Area for Coverage (Net Plot Area)	(A-Deductions)	50.85
Plot Area for FSI (Net Plot Area + Road Widening Area)	(A-Deductions)	50.85
Accession/Use Area		3.34
COVERAGE CHECK		
Proposed Coverage Area ( 60.24 % )		30.63
Total Coverage Area ( 60.24 % )		30.63
FAR CHECK		
Proposed Area of FAR		90.98
Total Area of FAR		90.98
BUILT UP AREA CHECK		
Total Proposed Built Up Area		91.89
ARCH/ENGR/SUPERVISOR (Regd)	OWNER	
DEVELOPMENT AUTHORITY	LOCAL BODY	

COLOR INDEX	
Plot Boundary	Black
Abutting Road	Green
Proposed Work (Coverage Area)	Red
Existing (To be retained)	Blue
Existing (To be demolished)	Yellow

MARGIN DETAIL:					
Building / Wing Name	Road Name	Front Margin	Rear Margin	Side1 Margin	Side2 Margin
AA-1 (KULDEEP KAUR)	4.57 M WIDE ROAD	1.71	0.90	0.00	0.90

FAR & Tenement Details (Table 4c-1)							
Building	No. of Same Bldg	Total Built Up Area (Sq.mt.)	Deductions (Area in Sq.mt.)		Proposed FAR Area (Sq.mt.)	Total FAR Area (Sq.mt.)	Trmt (No.)
			Void	Res.			
AA (KULDEEP KAUR)	1	91.89	0.91	0.91	90.98	90.98	01
Grand Total	1	91.89	0.91	0.91	90.98	90.98	01

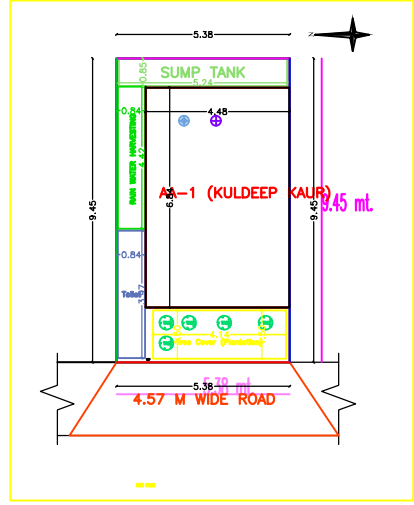
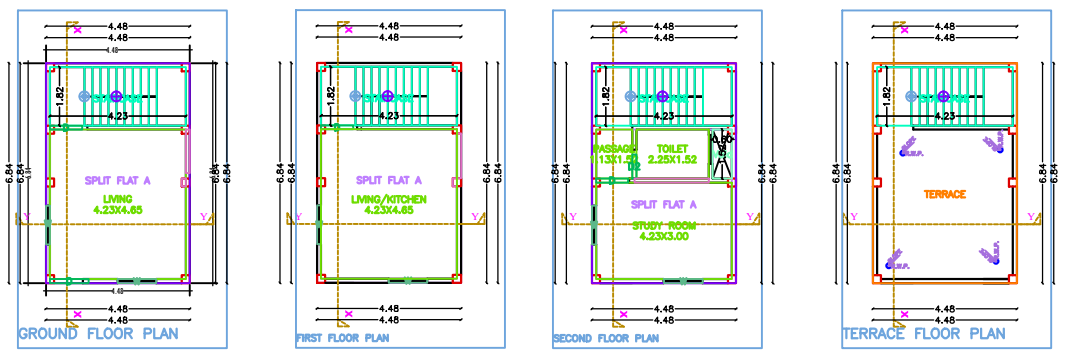
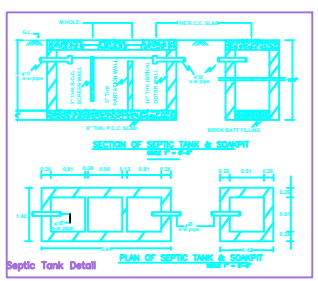
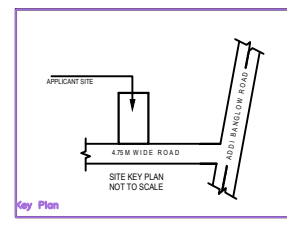
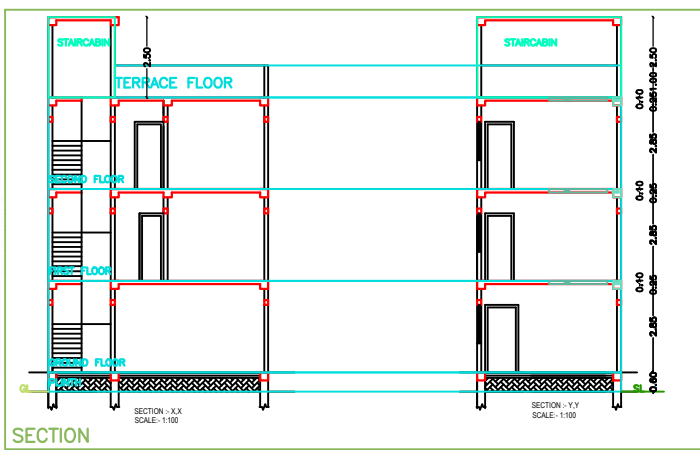
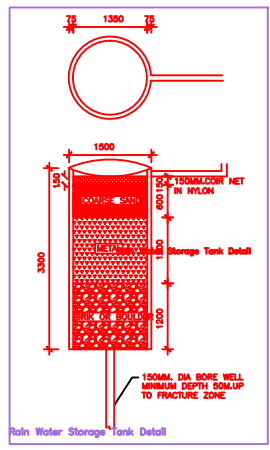
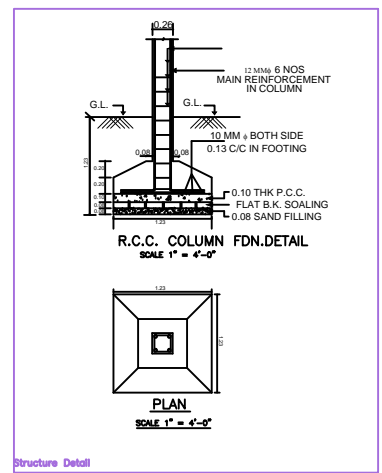
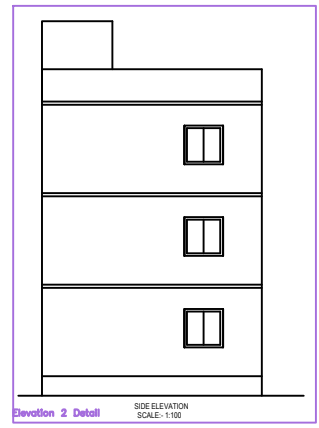
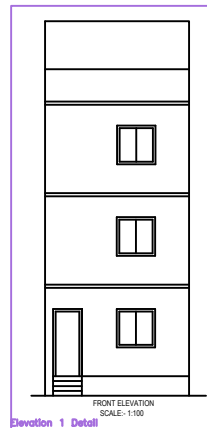

AA (KULDEEP KAUR)

Building :AA (KULDEEP KAUR)						
Floor Name	Total Built Up Area (Sq.mt.)	Deductions (Area in Sq.mt.)	Proposed FAR Area (Sq.mt.)	Total FAR Area (Sq.mt.)	Trmt (No.)	
Ground Floor	30.63	0.00	30.63	30.63	01	
First Floor	30.63	0.00	30.63	30.63	00	
Second Floor	30.63	0.91	29.72	29.72	00	
Terrace Floor	0.00	0.00	0.00	0.00	00	
Total	91.89	0.91	90.98	90.98	01	
Total Number of Same Buildings	1					
Total	91.89	0.91	90.98	90.98	01	

SCHEDULE OF JOINERY:				
BUILDING NAME	NAME	LENGTH	HEIGHT	NOS
AA (KULDEEP KAUR)	D2	0.75	2.10	01
AA (KULDEEP KAUR)	D	1.00	2.10	03
AA (KULDEEP KAUR)	D	1.20	2.10	01
Total	-	-	-	06

SCHEDULE OF JOINERY:				
BUILDING NAME	NAME	LENGTH	HEIGHT	NOS
AA (KULDEEP KAUR)	W	1.20		06
Total	-	-	-	06

UnitBUA Table for Building :AA (KULDEEP KAUR)						
FLOOR	Name	UnitBUA Type	UnitBUA Area	Carpet Area	No. of Rooms	No. of Tenement
GROUND FLOOR PLAN	SPLIT FLAT A	FLAT	58.06	57.71	1	1
Total	-	-	58.06	57.71	1	1