

FAR & Tenement Details (Table 4c-1)

Building	No. of Same Bldg	Total Built Up Area (Sq.mt.)	Deductions (Area in Sq.mt.)	Proposed FAR Area (Sq.mt.)	Total FAR Area (Sq.mt.)	Total Consumed Additional FAR Area (Sq.mt.)	Tnmt (No.)
AA (KULDEEP KAUR)	1	76.23	0.91	75.32	75.32	75.32	01
Grand Total :	1	76.23	0.91	75.32	75.32	75.32	01

Proposal Basic Information

Proposal File No.	JNP/IBP/0007/W14/2023
Owner Name	1 SMT KULDEEP KAUR 2 SRI TARANJEET SINGH
Khata No	381
Plot No	7160,7166
Village Name	Tilaiya
Use	Residential
SubUse	Bungalow/ Dwelling / Non Apartment

AREA STATEMENT

AREA DETAILS:		SQ.MT.
AREA OF PLOT (Minimum)	(A)	50.85
NET AREA OF PLOT (Gross Plot Area - Deduction from Gross Plot area)	(A-Deductions)	50.85
Deduction for Balance Plot Area (from Gross Plot Area)		
Common Plot		6.21
Total		6.21
BALANCE AREA OF PLOT (Net Plot Area - Recreational/Amenity space)	(A-Deductions)	44.64
PLOT AREA FOR COVERAGE (Net Plot Area)	(A-Deductions)	50.85
Plot Area for FAR (Net Plot Area + Road Widening Area)	(A-Deductions)	50.85
COVERAGE CHECK		
Permissible Coverage area (70.00 %)		35.59
Proposed Coverage Area (49.97 %)		25.41
Total Prop. Coverage Area (49.97 %)		25.41
Balance coverage area (20.02 %)		10.18
FAR CHECK		
Perm. FAR Area (1.500)		76.27
Total Perm. FAR area		76.27
Residential FAR		75.33
Proposed FAR Area		75.33
Total Proposed FAR Area		75.33
Consumed FAR (Factor)		1.48
Balance FAR Area		0.94
BUILT UP AREA CHECK		
Total Proposed BuiltUp Area		76.23
ARCHITECT (Regd)	MD SHOAB ALAM	
ENGINEER (Regd)		
SUPERVISOR (Regd)		
OWNER (Regd)	1 SMT KULDEEP KAUR 2 SRI TARANJEET SINGH	
DEVELOPMENT AUTHORITY	LOCAL BODY	

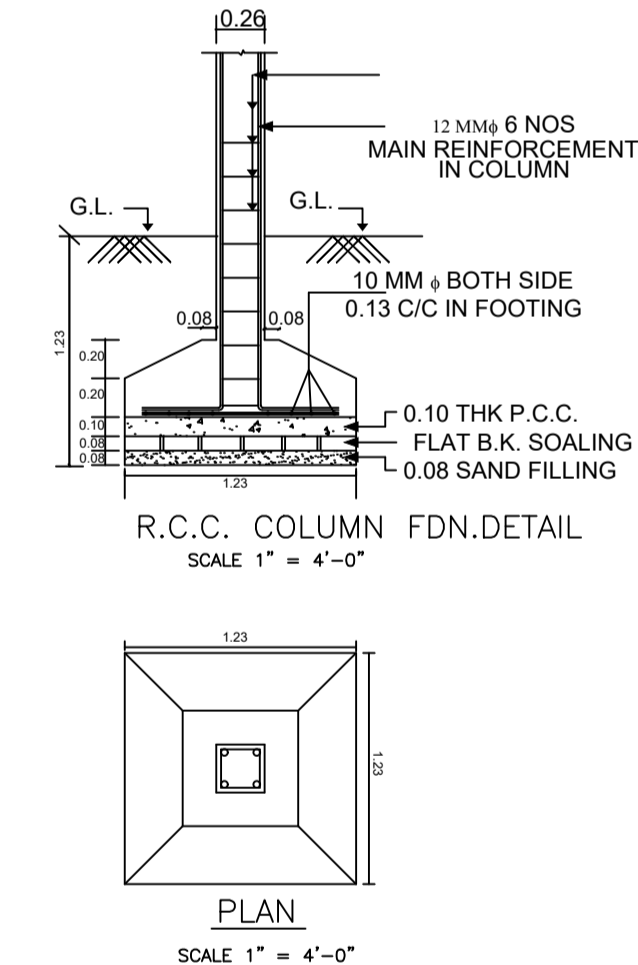
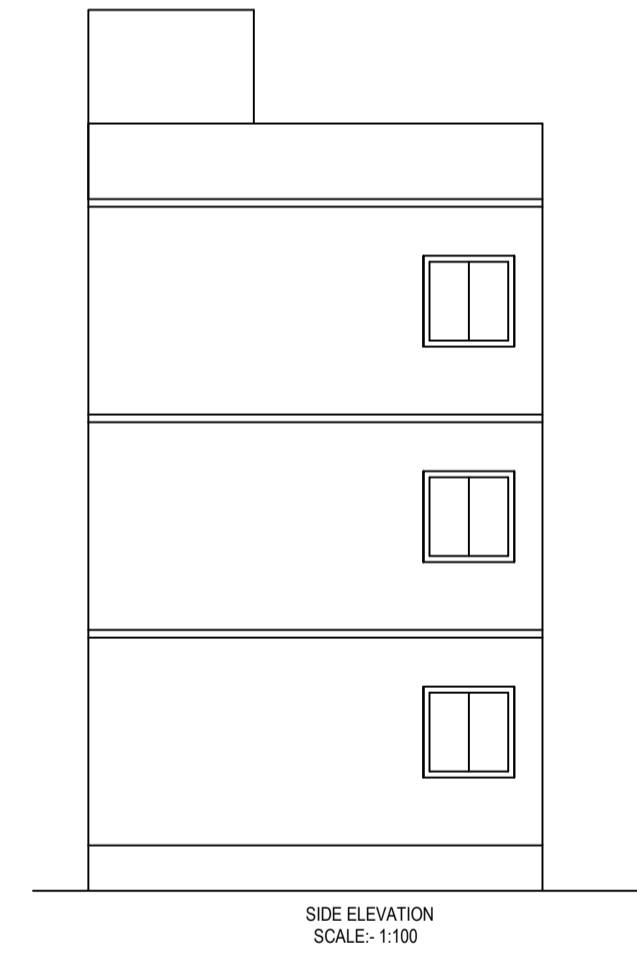
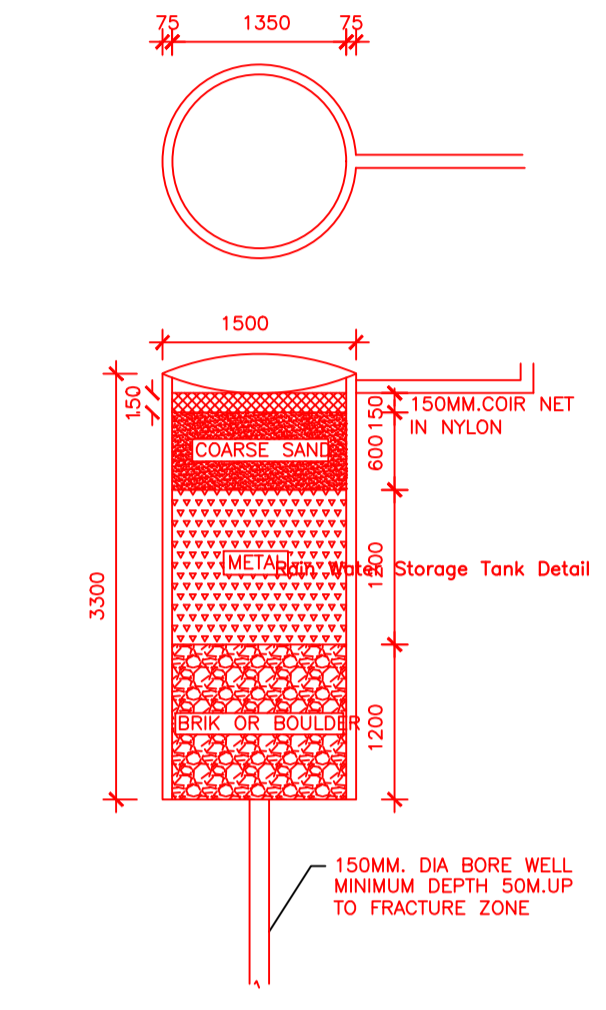
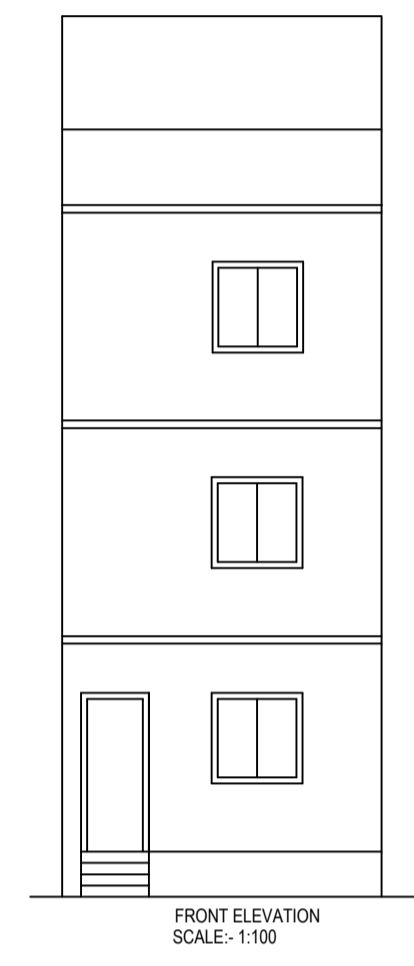
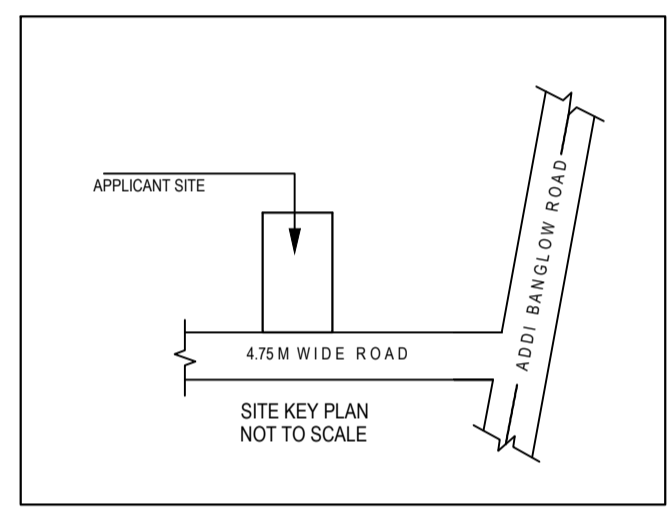
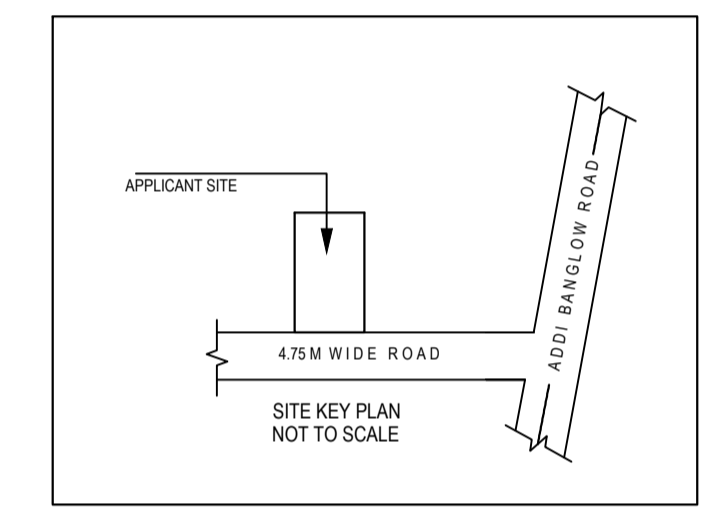
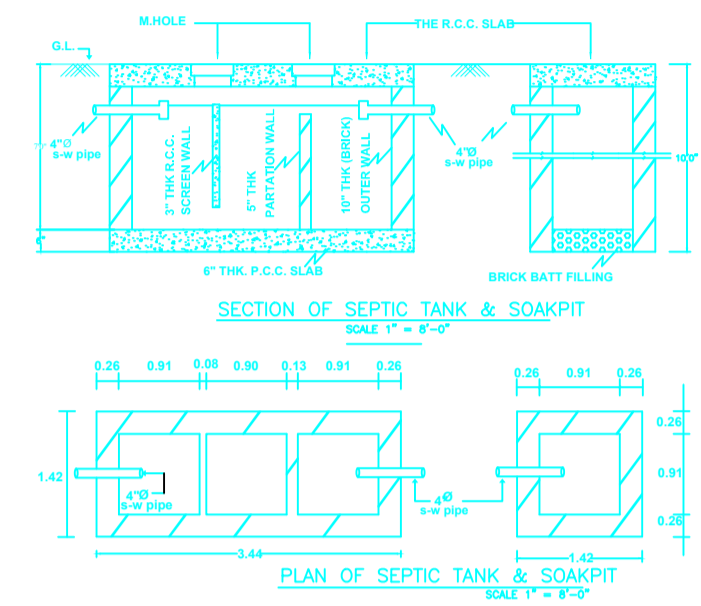

COLOR INDEX

PLOT BOUNDARY	Black
ABUTTING ROAD	Green
PROPOSED CONSTRUCTION	Red
COMMON PLOT	Yellow
ROAD WIDENING AREA	Blue
EXISTING (To be retained)	Orange
EXISTING (To be demolished)	White

Buildingwise Floor FAR Details

Floor Name	Building Name AA (KULDEEP KAUR)		Total	
	Proposed Built Up Area (Sq.mt.)	Proposed FAR Area (Sq.mt.)	Total Proposed Built Up Area (Sq.mt.)	Total FAR Area (Sq.mt.)
Ground Floor	25.41	25.41	25.41	25.41
First Floor	25.41	25.41	25.41	25.41
Second Floor	25.41	24.50	25.41	24.50
Terrace Floor	0.00	0.00	0.00	0.00
Total :	76.23	75.32	76.23	75.32

Building USE/SUBUSE Details

Building Name	Building Use	Building SubUse	Building Structure
AA (KULDEEP KAUR)	Residential	Bungalow/ Dwelling / Non Apartment	Non-Highrise

Building :AA (KULDEEP KAUR)

Floor Name	Total Built Up Area (Sq.mt.)	Deductions (Area in Sq.mt.)	Proposed FAR Area (Sq.mt.)	Total FAR Area (Sq.mt.)	Total Consumed Additional FAR Area (Sq.mt.)	Tnmt (No.)
Ground Floor	25.41	0.00	25.41	25.41	25.41	01
First Floor	25.41	0.00	25.41	25.41	25.41	00
Second Floor	25.41	0.91	24.50	24.50	24.50	00
Terrace Floor	0.00	0.00	0.00	0.00	0.00	00
Total :	76.23	0.91	75.32	75.32	75.32	01
Total Number of Same Buildings	1					
Total :	76.23	0.91	75.32	75.32	75.32	01

SCHEDULE OF DOOR:

BUILDING NAME	NAME	LENGTH	HEIGHT	NOS
AA (KULDEEP KAUR)	D2	0.75	2.10	01
AA (KULDEEP KAUR)	D	1.00	2.10	04
AA (KULDEEP KAUR)	D	1.20	2.10	01

SCHEDULE OF WINDOW/VENTILATION:

BUILDING NAME	NAME	LENGTH	HEIGHT	NOS
AA (KULDEEP KAUR)	V	0.60	0.60	01
AA (KULDEEP KAUR)	W	1.20	1.20	06

UnitBUA Table for Building :AA (KULDEEP KAUR)

FLOOR	Name	UnitBUA Type	UnitBUA Area	Carpet Area	No. of Rooms	No. of Tenement
GROUND FLOOR PLAN	SPLIT FLAT A	FLAT	44.66	44.31	1	1
FIRST FLOOR PLAN	SPLIT FLAT A	FLAT	0.00	0.00	1	0
SECOND FLOOR PLAN	SPLIT FLAT A	FLAT	0.00	0.00	3	0
Total:	-	-	44.66	44.31	5	1

LTP NAME AND SIGNATURE	STRUCTURAL ENG'S NAME AND SIGNATURE	BUILDER NAME AND SIGNATURE	DIGITAL SIGNATURE
MD SHOAB ALAM JNP/ENG/001/2017			