

SITE PLAN

FAR & Tenement Details (Table 4c-1)

Building	No. of Same Bldg	Total Built Up Area (Sq.mt.)	Proposed FAR Area (Sq.mt.) Resi.	Total FAR Area (Sq.mt.)	Total Consumed Additional FAR Area (Sq.mt.)	Tnmt (No.)
AA (SMT PUNAM DEVI)	1	166.32	166.32	166.32	166.32	01
Grand Total :	1	166.32	166.32	166.32	166.32	01

Proposal Basic Information

Proposal File No.	JNP/IB/0006/W23/2023
Owner Name	SMT PUNAM DEVI
Khata No	540
Plot No	5835/6308
Village Name	Gomo
Use	Residential
SubUse	Bungalow/ Dwelling / Non Apartment

AREA STATEMENT	VERSION NO. : 1.0.65
JHUMRITILAIYA NAGAR PARISHAD	VERSION DATE: 16/10/2020
PROJECT DETAIL:	
Region: JHARKHAND URBAN LOCAL BODIES	Plot Use: Residential
District: KODERMA	Plot SubUse: Bungalow/ Dwelling / Non Apartment
Authority: JHUMRITILAIYA NAGAR PARISHAD	PlotNearbyReligiousStructure: NA
Inward No: JNP/IB/0006/W23/2023	Plot/SubPlot No: 5835/6308
Application Type: General Proposal	North: Road Width - 4.57M WIDE P.C.C ROAD
Project Type: Building Permission	South: Plot No. - SHALIGRAM MODI
Nature of Development: New	East: Plot No. - TODAY VENDEE JYOTI RANI
Location of Development Area: Old Area	West: Plot No. - AJIT KUMAR BARNWAL
AREA DETAILS:	
AREA OF PLOT (Minimum)	(A) 93.22
NET AREA OF PLOT(Gross Plot Area - Deduction from Gross Plot area)	(A-Deductions) 93.22
Deduction for Balance Plot Area(from Gross Plot Area)	
Common Plot	9.69
BALANCE AREA OF PLOT(Net Plot Area - Recreational/Amenity space)	(A-Deductions) 83.53
PLOT AREA FOR COVERAGE(Net Plot Area)	(A-Deductions) 93.22
Plot Area for FAR (Net Plot Area + RoadWidening Area)	(A-Deductions) 93.22
COVERAGE CHECK	
Permissible Coverage area (70.00 %)	65.25
Proposed Coverage Area (59.47 %)	55.44
Total Prop. Coverage Area (59.47 %)	55.44
Balance coverage area (10.52 %)	9.81
FAR CHECK	
Perm. FAR Area (1.800)	167.80
Total Perm. FAR area	167.80
Residential FAR	166.31
Proposed FAR Area	166.31
Total Proposed FAR Area	166.31
Consumed FAR (Factor)	1.78
Balance FAR Area	1.49
BUILT UP AREA CHECK	
Total Proposed BuiltUp Area	166.32
ARCHITECT (Regd)	MD SHOAB ALAM
ENGINEER (Regd)	
SUPERVISOR (Regd)	
OWNER (Regd)	SMT PUNAM DEVI
DEVELOPMENT AUTHORITY LOCAL BODY	

COLOR INDEX	
PLOT BOUNDARY	Black
ABUTTING ROAD	Green
PROPOSED CONSTRUCTION	Red
COMMON PLOT	Yellow
ROAD WIDENING AREA	Blue
EXISTING (To be retained)	Blue
EXISTING (To be demolished)	Yellow

Buildingwise Floor FAR Details

Floor Name	Building Name AA (SMT PUNAM DEVI)		Total	
	Proposed Built Up Area (Sq.mt.)	Proposed FAR Area (Sq.mt.)	Total Proposed Built Up Area (Sq.mt.)	Total FAR Area (Sq.mt.)
Ground Floor	55.44	55.44	55.44	55.44
First Floor	55.44	55.44	55.44	55.44
Second Floor	55.44	55.44	55.44	55.44
Terrace Floor	0.00	0.00	0.00	0.00
Total :	166.32	166.32	166.32	166.32

Building USE/SUBUSE Details

Building Name	Building Use	Building SubUse	Building Structure
AA (SMT PUNAM DEVI)	Residential	Bungalow/ Dwelling / Non Apartment	Non-Highrise

LTP NAME AND SIGNATURE	STRUCTURAL ENG'S NAME AND SIGNATURE	BUILDER NAME AND SIGNATURE	DIGITAL SIGNATURE
MD SHOAB ALAM JNP/ENG/0001/2017			

Proposal Basic Information

Proposal File No.	JNP/IB/0006/W23/2023
Owner Name	SMT PUNAM DEVI
Khata No	540
Plot No	5835/6308
Village Name	Gomo
Use	Residential
SubUse	Bungalow/ Dwelling / Non Apartment

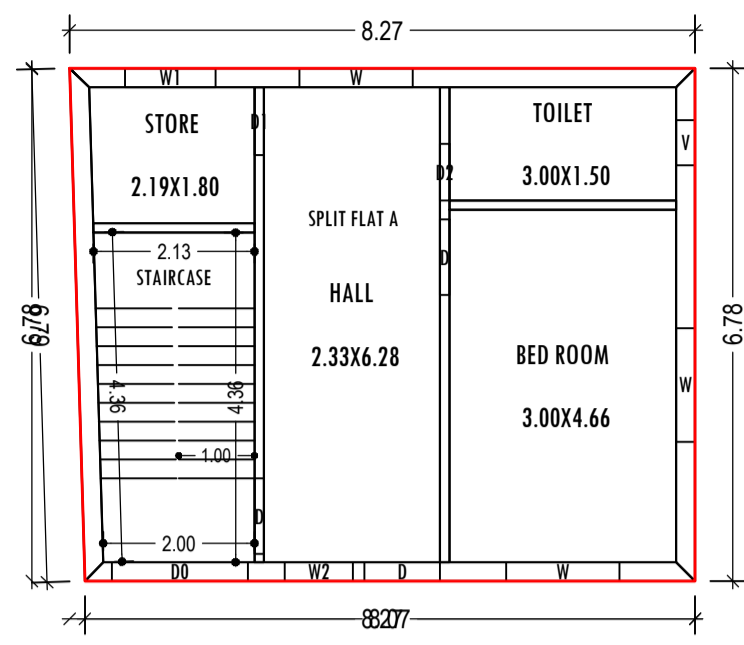

GROUND FLOOR PLAN (Proposed) (SCALE 1:100)

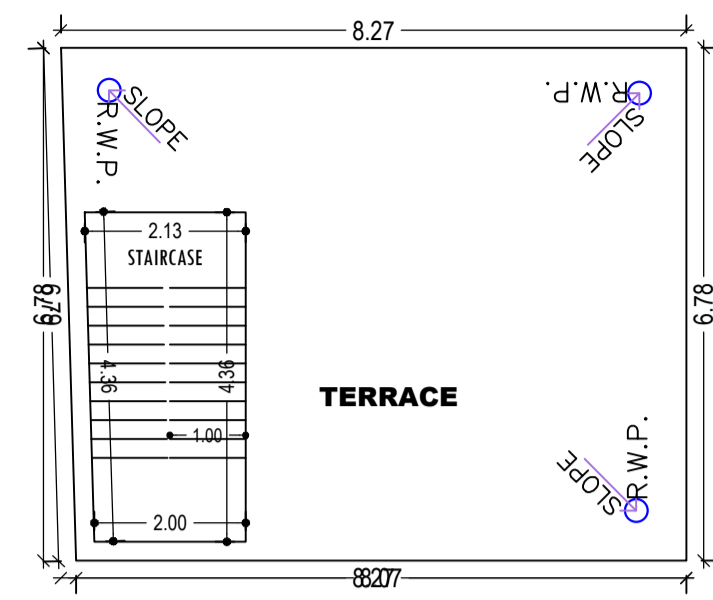

TERRACE FLOOR PLAN (SCALE 1:100)

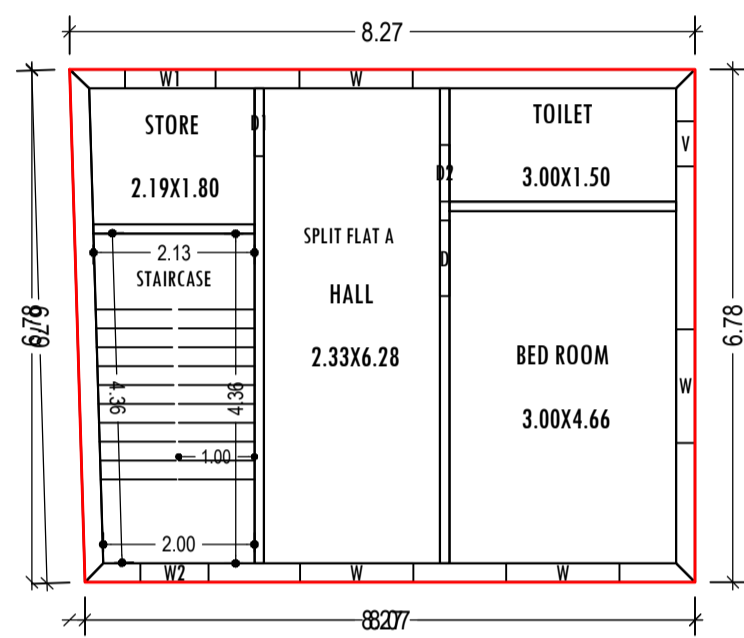

FIRST FLOOR PLAN (Proposed) (SCALE 1:100)

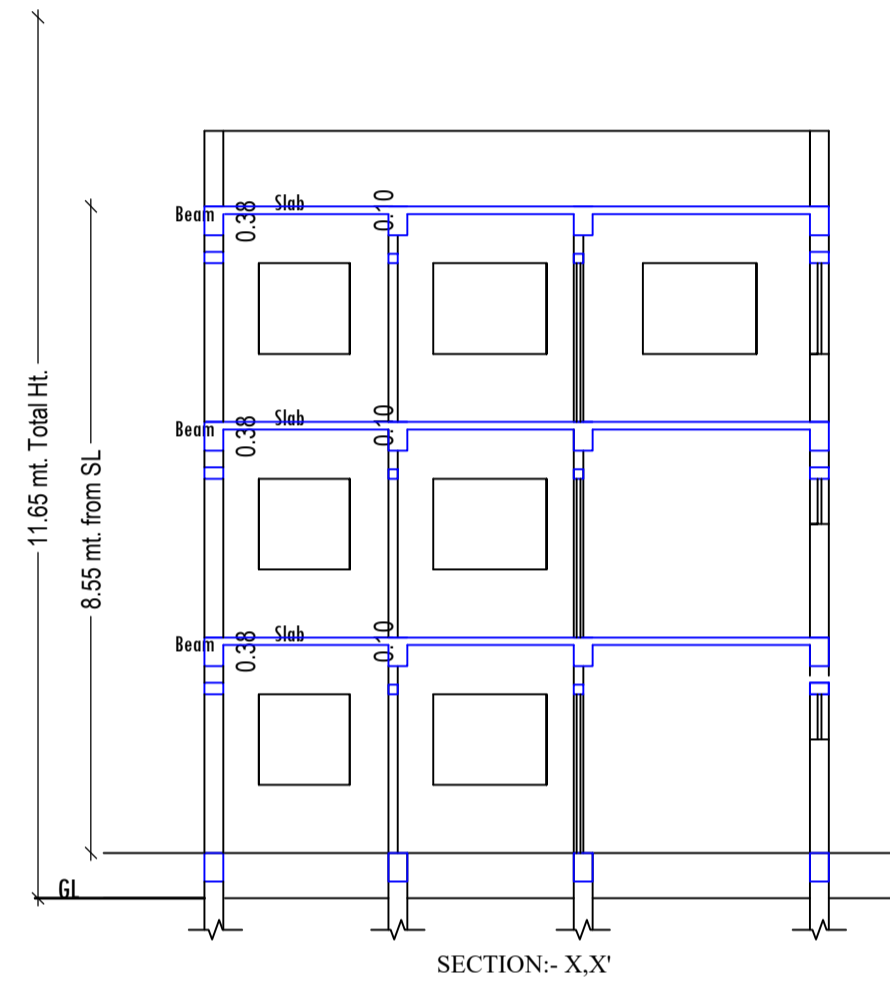

SECTION-- X-X'

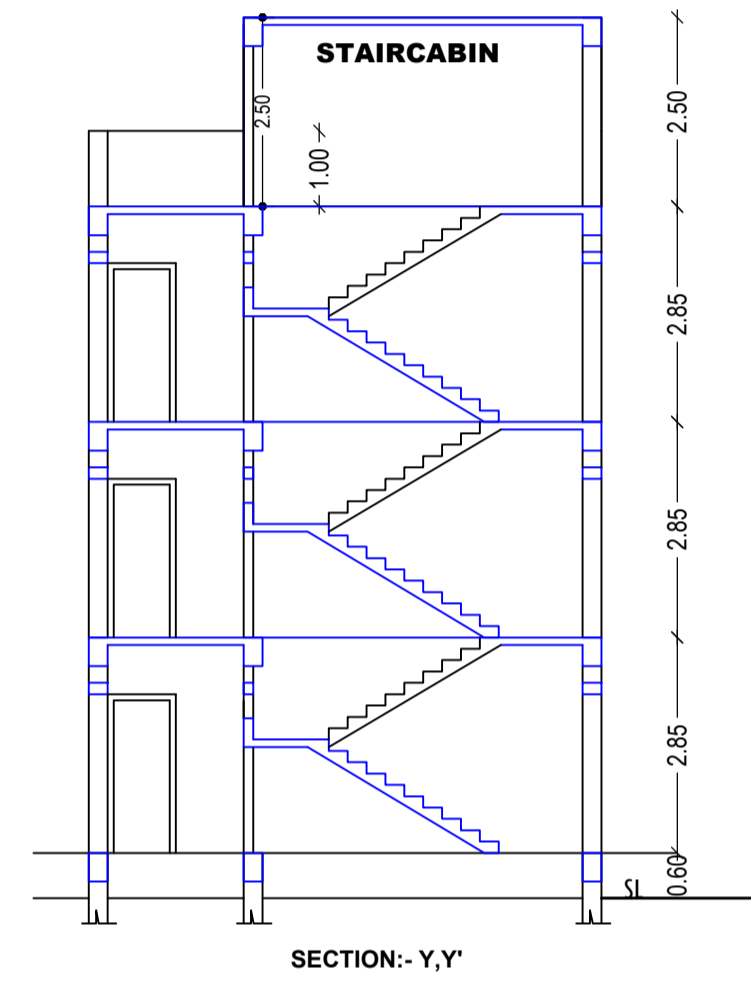

SECTION-- Y-Y'

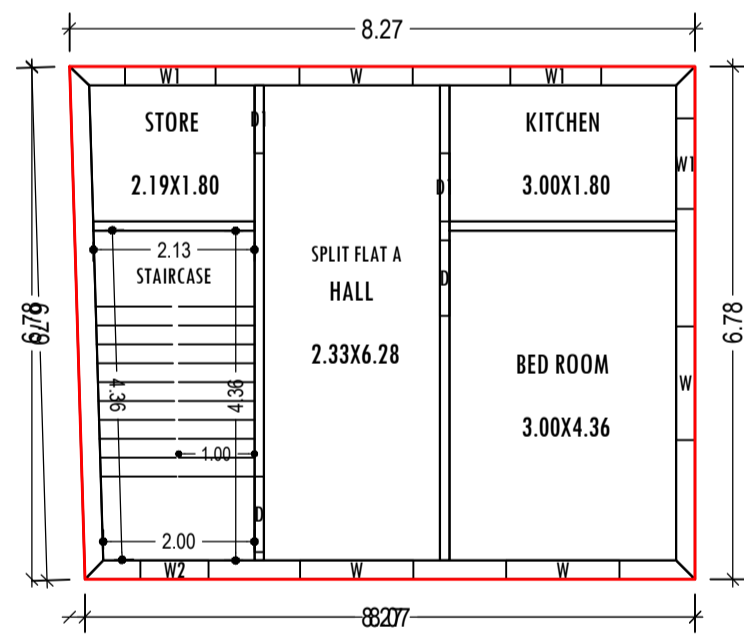

SECOND FLOOR PLAN (Proposed) (SCALE 1:100)

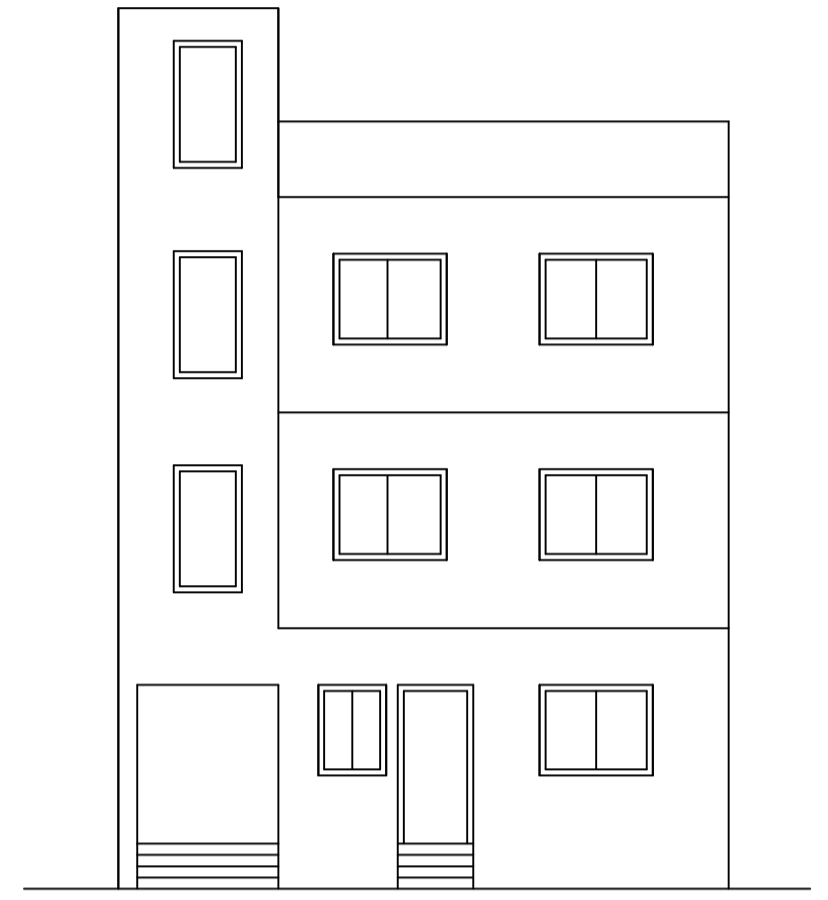
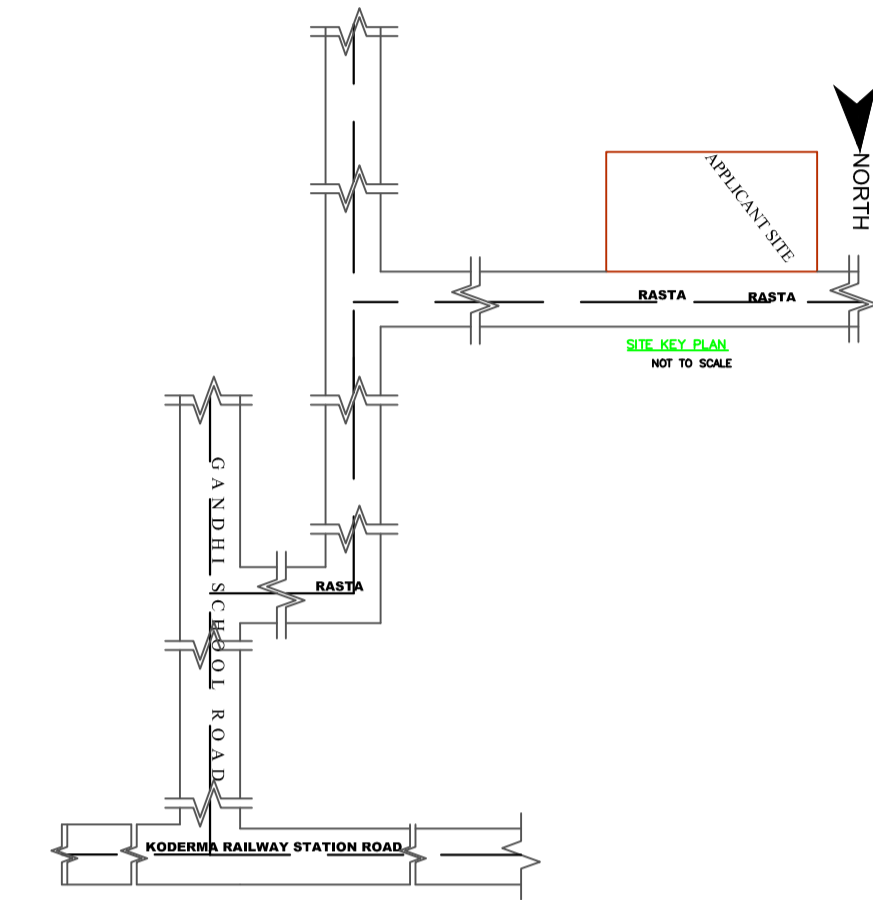

FRONT ELEVATION

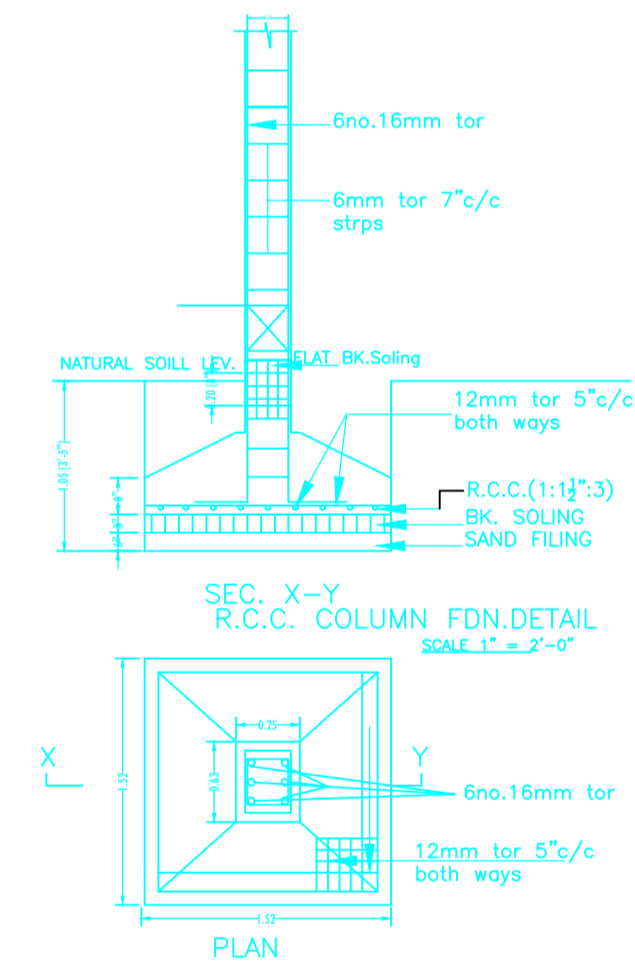

SCALE=1":2'-0"

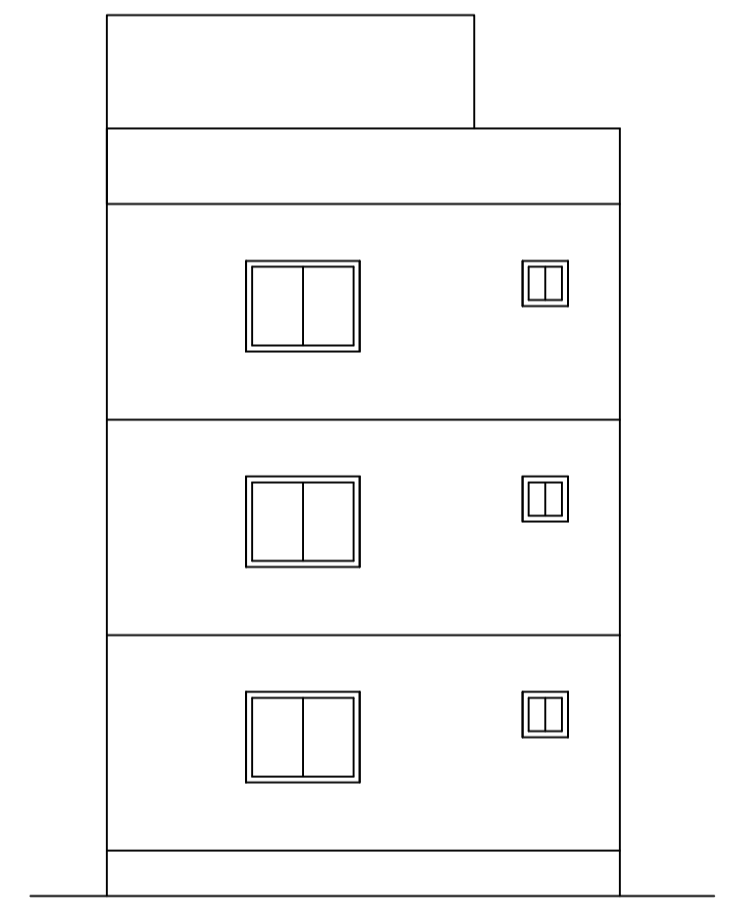

SIDE ELEVATION

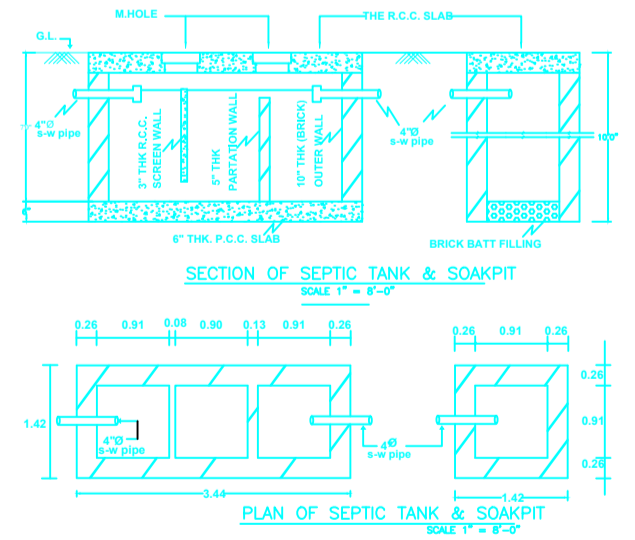

PLAN OF SEPTIC TANK & SOAKPIT

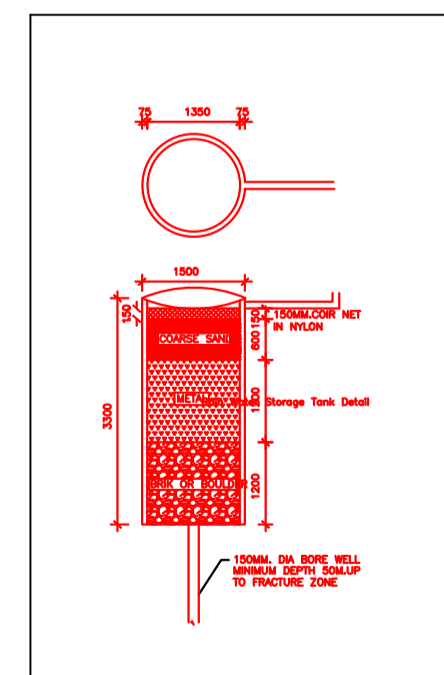

SCHEDULE OF DOOR:

BUILDING NAME	NAME	LENGTH	HEIGHT	NOS
AA (SMT PUNAM DEVI)	D2	0.75	2.10	02
AA (SMT PUNAM DEVI)	D1	0.90	2.10	04
AA (SMT PUNAM DEVI)	D	1.00	2.10	06

SCHEDULE OF WINDOW/VENTILATION:

BUILDING NAME	NAME	LENGTH	HEIGHT	NOS
AA (SMT PUNAM DEVI)	V	0.60	0.60	02
AA (SMT PUNAM DEVI)	W2	0.90	1.20	03
AA (SMT PUNAM DEVI)	W1	1.20	1.20	05
AA (SMT PUNAM DEVI)	W	1.50	1.20	11

UnitBUA Table for Building -AA (SMT PUNAM DEVI)

FLOOR	Name	UnitBUA Type	UnitBUA Area	Carpet Area	No. of Rooms	No. of Tenement
GROUND FLOOR PLAN	SPLIT FLAT A	FLAT	115.14	111.66	4	1
FIRST FLOOR PLAN	SPLIT FLAT A	FLAT	0.00	0.00	4	0
SECOND FLOOR PLAN	SPLIT FLAT A	FLAT	0.00	0.00	4	0
Total:	-	-	115.14	111.66	12	1

Building -AA (SMT PUNAM DEVI)

Floor Name	Total Built Up Area (Sq.mt.)	Proposed FAR Area (Sq.mt.)	Total FAR Area (Sq.mt.)	Total Consumed Additional FAR Area (Sq.mt.)	Tnmt (No.)
Ground Floor	55.44	55.44	55.44	55.44	01
First Floor	55.44	55.44	55.44	55.44	00
Second Floor	55.44	55.44	55.44	55.44	00
Terrace Floor	0.00	0.00	0.00	0.00	00
Total:	166.32	166.32	166.32	166.32	01
Total Number of Same Buildings	1				
Total:	166.32	166.32	166.32	166.32	01

LTP NAME AND SIGNATURE	STRUCTURAL ENG'S NAME AND SIGNATURE	BUILDER NAME AND SIGNATURE	DIGITAL SIGNATURE
MD SHOAB ALAM JNP/ENG/0001/2017			