

SITE PLAN

FAR & Tenement Details (Table 4c-1)

Building	No. of Same Bldg	Total Built Up Area (Sq.mt.)	Proposed FAR Area (Sq.mt.) Resi.	Total FAR Area (Sq.mt.)	Total Consumed Additional FAR Area (Sq.mt.)	Trmt (No.)
AA (SMT KANTI SINHA)	1	305.58	305.58	305.58	305.58	01
Grand Total :	1	305.58	305.58	305.58	305.58	01

Proposal Basic Information

Proposal File No.	JNP/IBP/0012/W23/2023
Owner Name	SMT KANTI SINHA
Khata No	106
Plot No	5863
Village Name	Gomo
Use	Residential
SubUse	Bungalow/ Dwelling / Non Apartment

AREA STATEMENT	VERSION NO. : 1.0.65
JHUMRITILAIYA NAGAR PARISHAD	VERSION DATE: 16/10/2020
PROJECT DETAIL:	
Region: JHARKHAND URBAN LOCAL BODIES	Plot Use: Residential
District: KODERMA	Plot SubUse: Bungalow/ Dwelling / Non Apartment
Authority: JHUMRITILAIYA NAGAR PARISHAD	PlotNearbyReligiousStructure: NA
Inward No: JNP/IBP/0012/W23/2023	Plot/SubPlot No: 5863
Application Type: General Proposal	North: Road Width - 3.05M WIDE KATCHA RASTA
Project Type: Building Permission	South: Plot No. - LAND OF RAJENDRA RAM & SAVITA KUMARI
Nature of Development: New	East: Road Width - 4.87M WIDE ROAD
Location of Development Area: Old Area	West: Plot No. - LAND & HOUSE OF SMT BACHCHI DEVI
AREA DETAILS:	
AREA OF PLOT (Minimum)	(A) 401.37
NET AREA OF PLOT(Gross Plot Area - Deduction from Gross Plot area)	(A-Deductions) 401.37
Deduction for Balance Plot Area(from Gross Plot Area)	
Common Plot	42.17
Total	42.17
BALANCE AREA OF PLOT(Net Plot Area - Recreational/Amenity space)	(A-Deductions) 359.20
PLOT AREA FOR COVERAGE(Net Plot Area)	(A-Deductions) 401.37
Plot Area for FAR (Net Plot Area + RoadWidening Area)	(A-Deductions) 401.37
COVERAGE CHECK	
Permissible Coverage area (60.00 %)	240.82
Proposed Coverage Area (38.07 %)	152.79
Total Prop. Coverage Area (38.07 %)	152.79
Balance coverage area (21.93 %)	88.03
FAR CHECK	
Perm. FAR Area (1.800)	722.47
Total Perm. FAR area	722.47
Residential FAR	305.58
Proposed FAR Area	305.58
Total Proposed FAR Area	305.58
Consumed FAR (Factor)	0.76
Balance FAR Area	416.89
BUILT UP AREA CHECK	
Total Proposed BuiltUp Area	305.58
ARCHITECT (Regd)	MD SHOAB ALAM
ENGINEER (Regd)	
SUPERVISOR (Regd)	
OWNER (Regd)	SMT KANTI SINHA
DEVELOPMENT AUTHORITY	LOCAL BODY

COLOR INDEX	
PLOT BOUNDARY	Black
ABUTTING ROAD	Green
PROPOSED CONSTRUCTION	Red
COMMON PLOT	Yellow
ROAD WIDENING AREA	Blue
EXISTING (To be retained)	Blue
EXISTING (To be demolished)	Yellow

Buildingwise Floor FAR Details

Floor Name	Building Name		Total	
	Proposed Built Up Area (Sq.mt.)	Proposed FAR Area (Sq.mt.)	Total Proposed Built Up Area (Sq.mt.)	Total FAR Area (Sq.mt.)
Ground Floor	152.79	152.79	152.79	152.79
First Floor	152.79	152.79	152.79	152.79
Terrace Floor	0.00	0.00	0.00	0.00
Total :	305.58	305.58	305.58	305.58

Building USE/SUBUSE Details

Building Name	Building Use	Building SubUse	Building Structure
AA (SMT KANTI SINHA)	Residential	Bungalow/ Dwelling / Non Apartment	Non-Highrise

LTP NAME AND SIGNATURE	STRUCTURAL ENG'S NAME AND SIGNATURE	BUILDER NAME AND SIGNATURE	DIGITAL SIGNATURE
MD SHOAB ALAM JNP/ENG/001/2017			

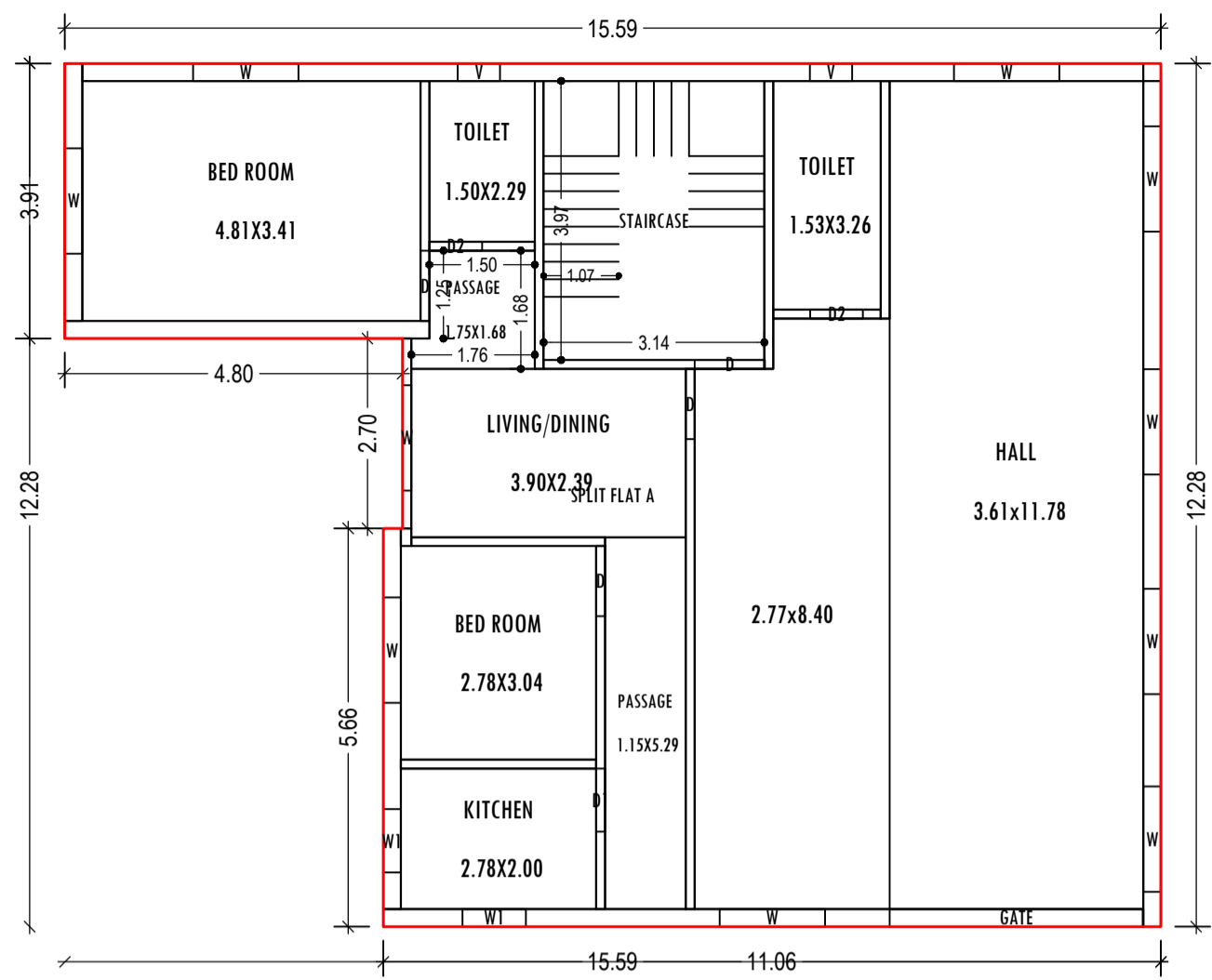

GROUND FLOOR PLAN
(Proposed)
(SCALE 1:100)

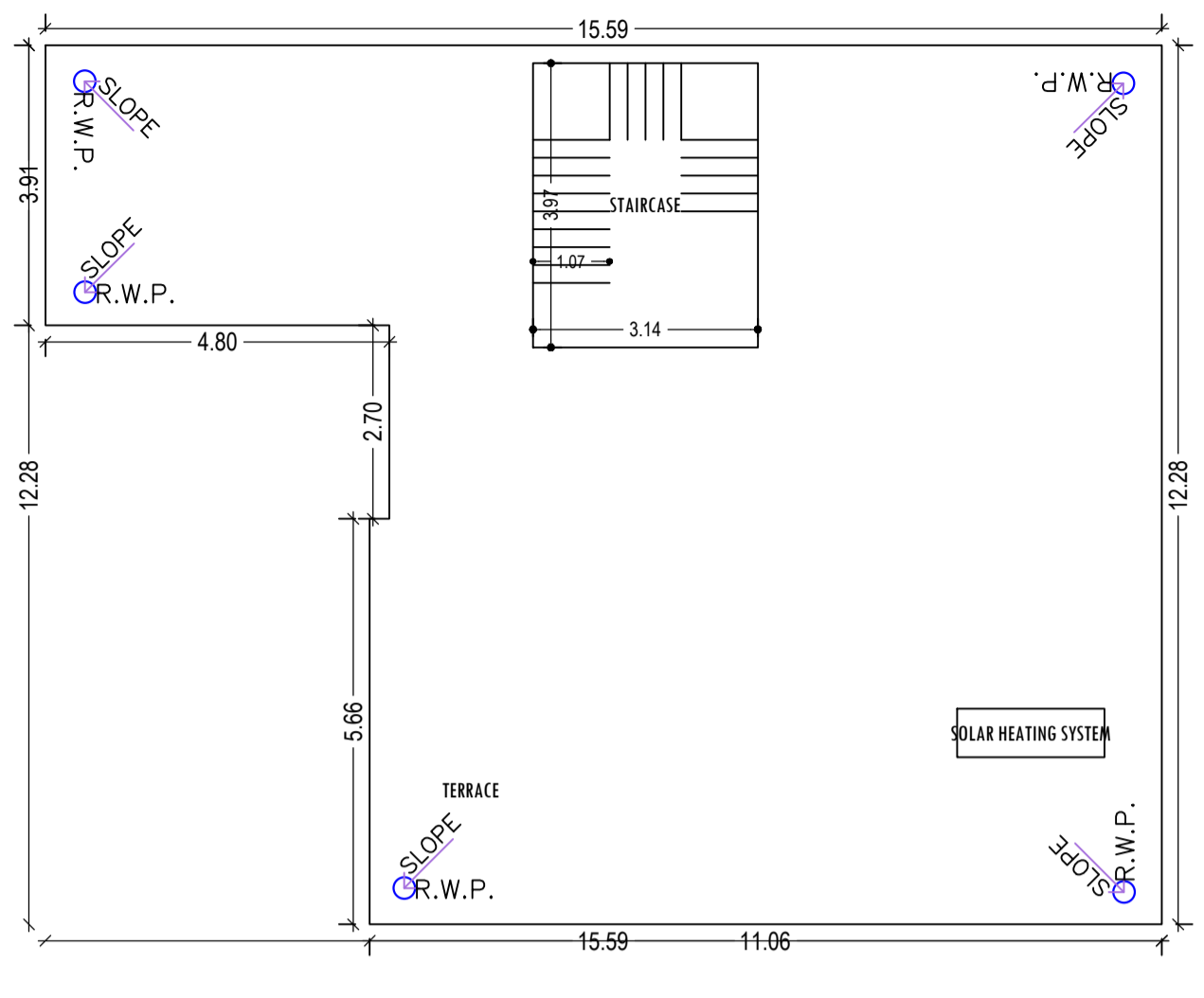

TERRACE FLOOR PLAN
(SCALE 1:100)

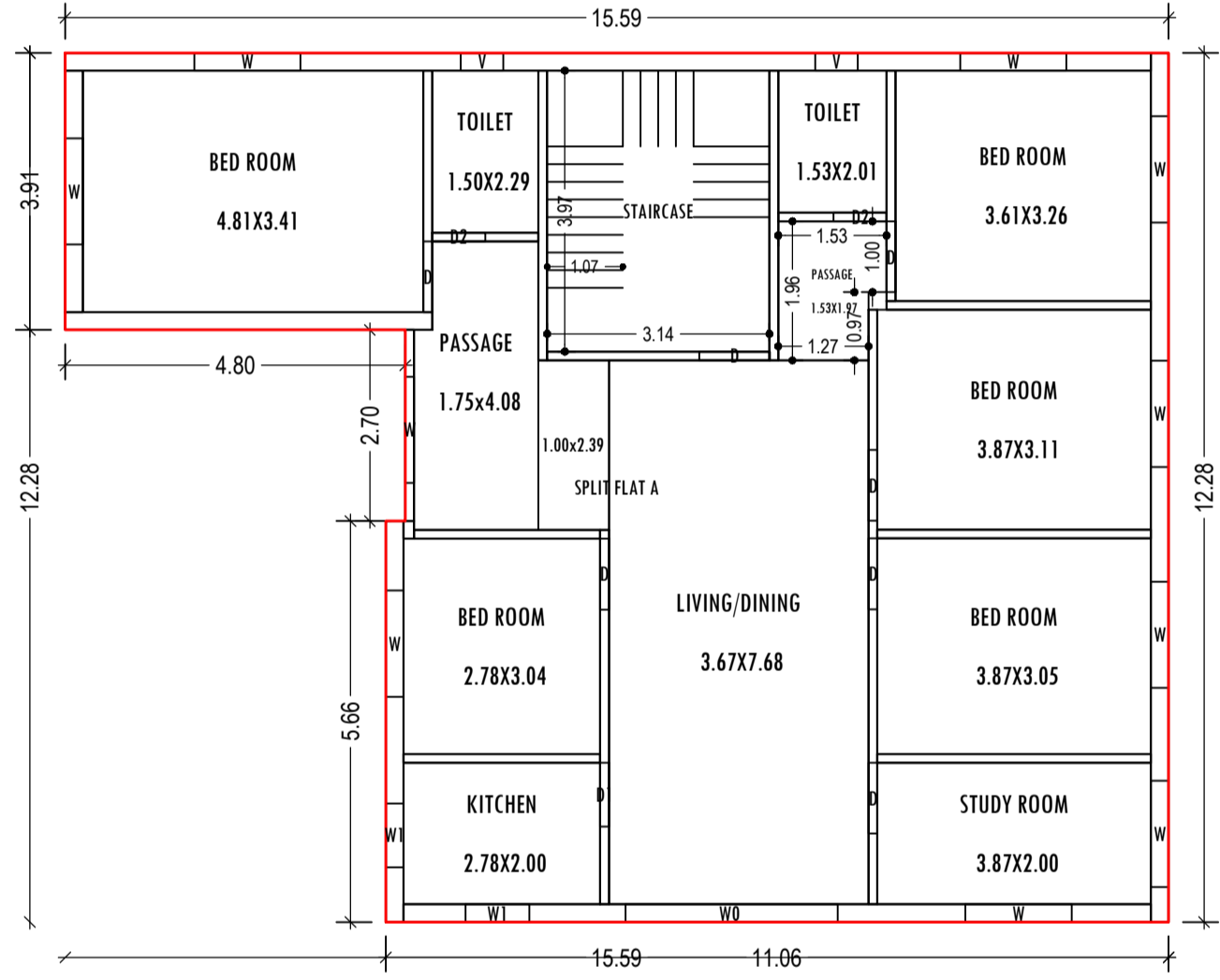

FIRST FLOOR PLAN
(Proposed)
(SCALE 1:100)

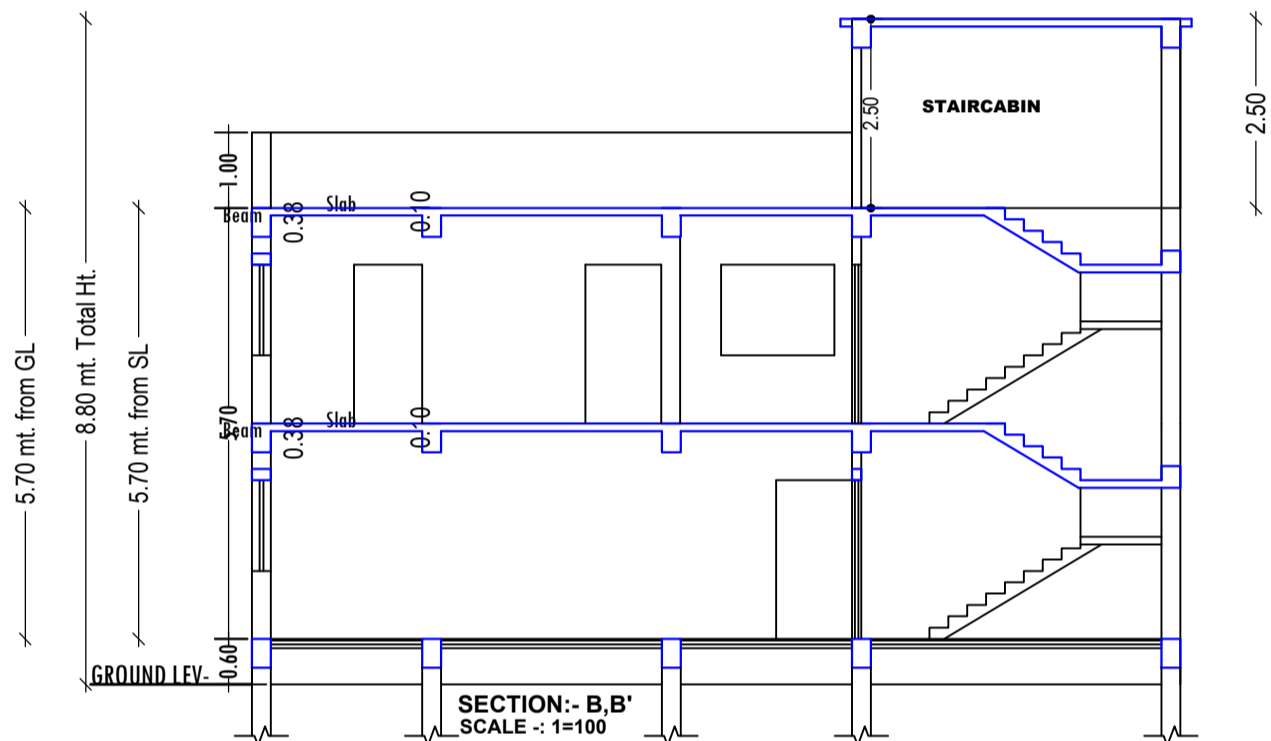

SECTION:- B-B'
SCALE - 1=100

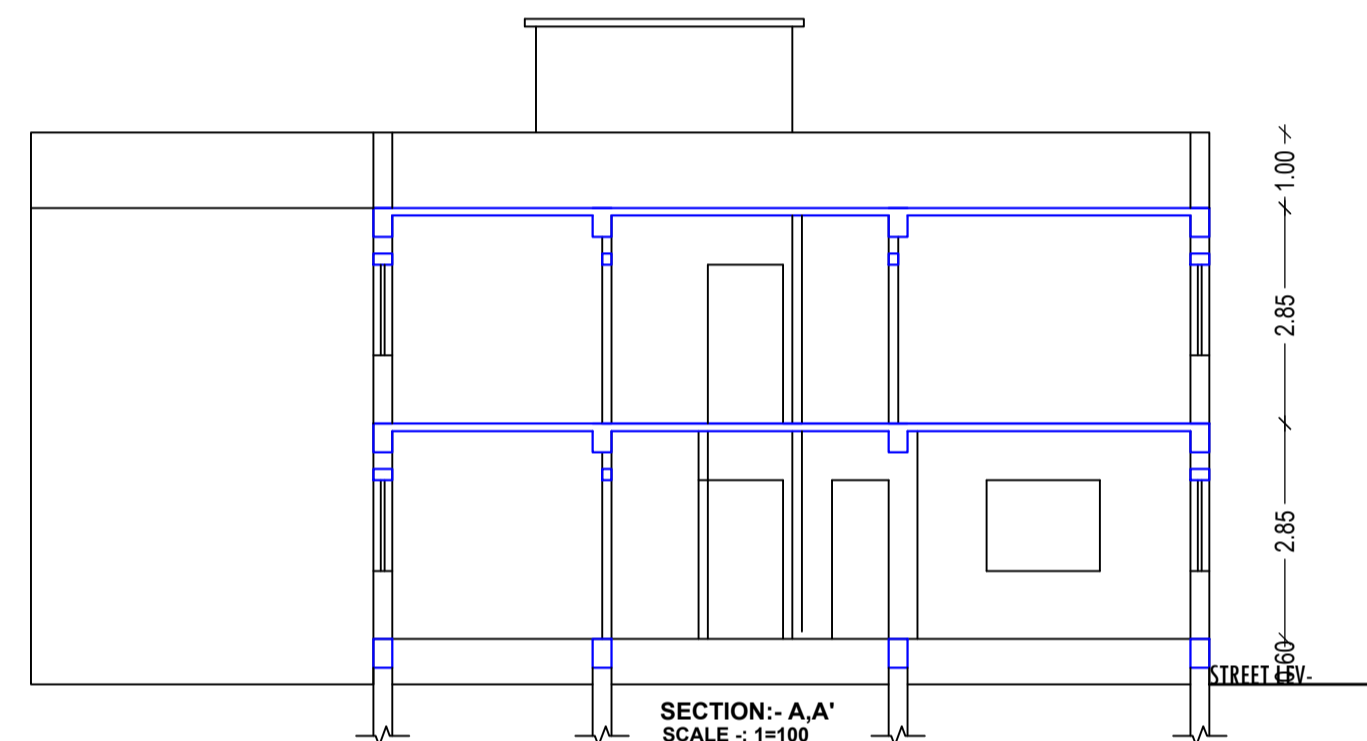

SECTION:- A-A'
SCALE - 1=100

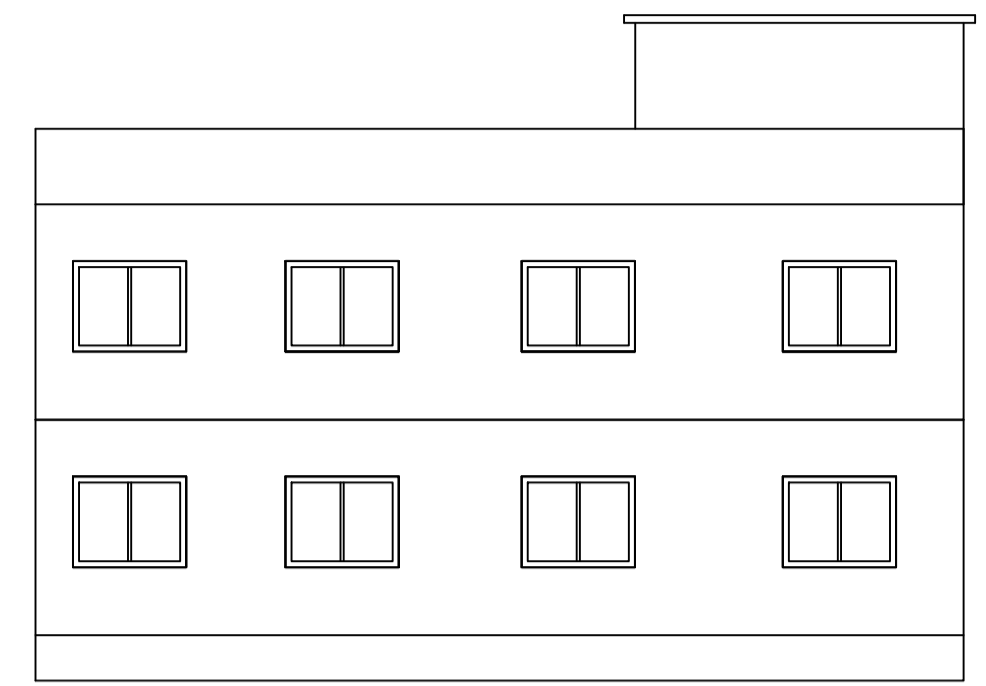

SIDE ELEVATION
SCALE - 1=100

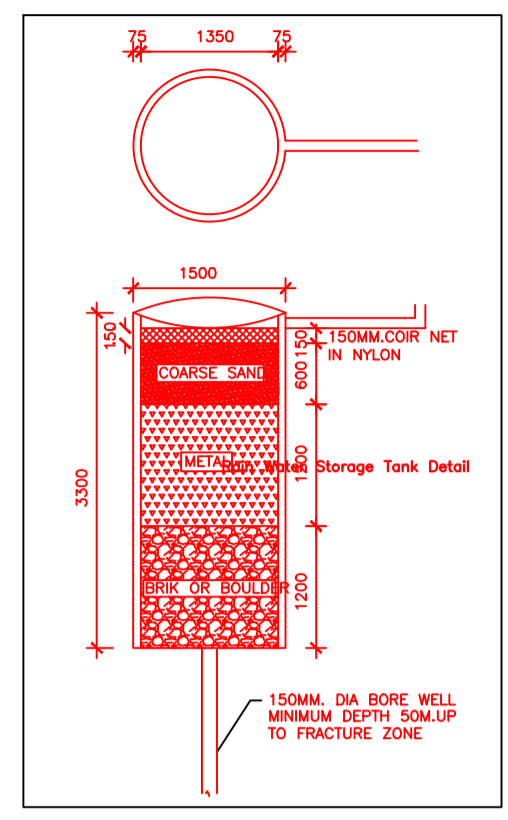

Proposal Basic Information

Proposal File No.	JNP/BP/0012/W23/2023
Owner Name	SMT KANTI SINHA
Khata No	106
Plot No	5863
Village Name	Gomo
Use	Residential
SubUse	Bungalow/ Dwelling / Non Apartment

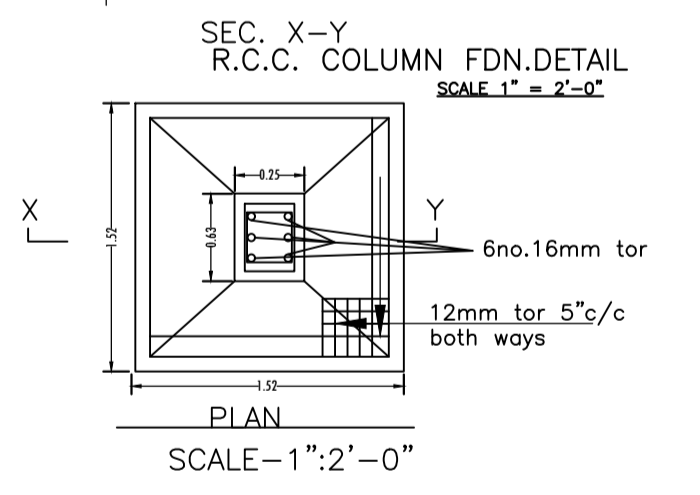
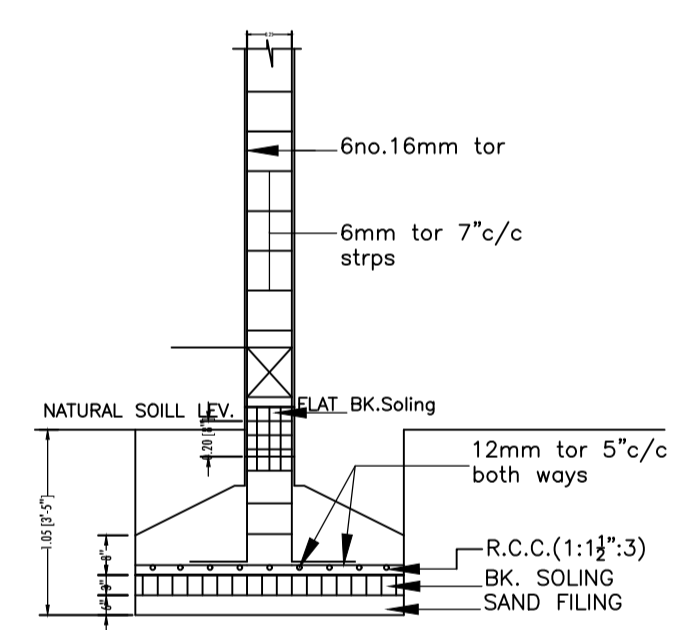
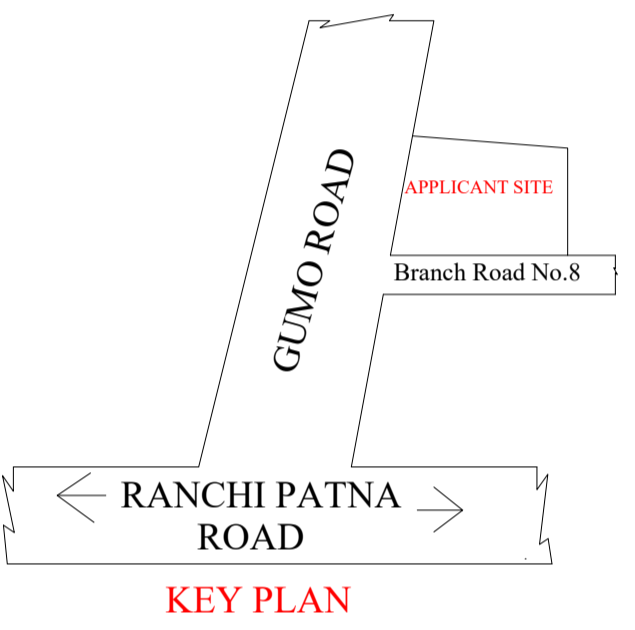
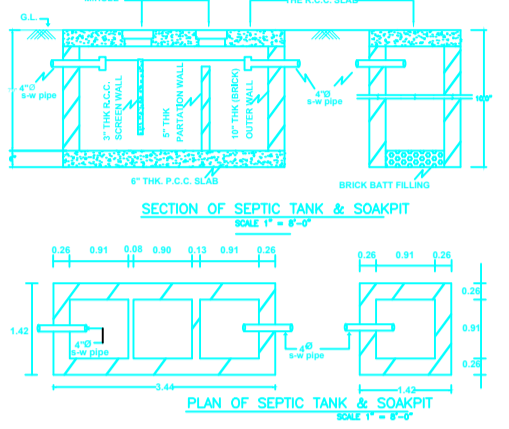

Building :AA (SMT KANTI SINHA)

Floor Name	Total Built Up Area (Sq.mt.)	Proposed FAR Area (Sq.mt.) Resi.	Total FAR Area (Sq.mt.)	Total Consumed Additional FAR Area (Sq.mt.)	Tnmt (No.)
Ground Floor	152.79	152.79	152.79	152.79	01
First Floor	152.79	152.79	152.79	152.79	00
Terrace Floor	0.00	0.00	0.00	0.00	00
Total :	305.58	305.58	305.58	305.58	01
Total Number of Same Buildings	1				
Total :	305.58	305.58	305.58	305.58	01

SCHEDULE OF DOOR:

BUILDING NAME	NAME	LENGTH	HEIGHT	NOS
AA (SMT KANTI SINHA)	D2	0.75	2.10	04
AA (SMT KANTI SINHA)	D1	0.90	2.10	02
AA (SMT KANTI SINHA)	D	1.00	2.10	11
AA (SMT KANTI SINHA)	GATE	3.60	2.40	01

SCHEDULE OF WINDOW/VENTILATION:

BUILDING NAME	NAME	LENGTH	HEIGHT	NOS
AA (SMT KANTI SINHA)	V	0.60	0.60	04
AA (SMT KANTI SINHA)	W1	0.90	1.20	04
AA (SMT KANTI SINHA)	W	1.50	1.20	20
AA (SMT KANTI SINHA)	W0	3.00	1.20	01

UnitBUA Table for Building :AA (SMT KANTI SINHA)

FLOOR	Name	UnitBUA Type	UnitBUA Area	Carpet Area	No. of Rooms	No. of Tenement
GROUND FLOOR PLAN	SPLIT FLAT A	FLAT	250.98	242.42	9	1
FIRST FLOOR PLAN	SPLIT FLAT A	FLAT	0.00	0.00	12	0
Total:	-	-	250.98	242.42	21	1

LTP NAME AND SIGNATURE	STRUCTURAL ENG'S NAME AND SIGNATURE	BUILDER NAME AND SIGNATURE	DIGITAL SIGNATURE
MD SHOAIB ALAM JNP/ENG/0001/2017			