

SITE PLAN

FAR & Tenement Details (Table 4c-1)

Building	No. of Same Bldg	Total Built Up Area (Sq.mt.)	Proposed FAR Area (Sq.mt.) Resi.	Total FAR Area (Sq.mt.)	Total Consumed Additional FAR Area (Sq.mt.)	Tnmt (No.)
AA (WASIMA KHATUN)	1	192.70	192.70	192.70	192.70	01
Grand Total :	1	192.70	192.70	192.70	192.70	01

Proposal Basic Information

Proposal File No.	JNP/IBP/0005/W06/2023
Owner Name	WASIMA KHATUN
Khata No	82
Plot No	1248
Village Name	Asana
Use	Residential
SubUse	Bungalow/ Dwelling / Non Apartment

AREA STATEMENT	VERSION NO. : 1.0.65
JHUMRITILAIYA NAGAR PARISHAD	VERSION DATE: 16/10/2020
PROJECT DETAIL:	
Region: JHARKHAND URBAN LOCAL BODIES	Plot Use: Residential
District: KODERMA	Plot SubUse: Bungalow/ Dwelling / Non Apartment
Authority: JHUMRITILAIYA NAGAR PARISHAD	PlotNearbyReligiousStructure: NA
Inward No: JNP/IBP/0005/W06/2023	Plot/SubPlot No: 1248
Application Type: General Proposal	North: Plot No. - OWN LAND VENDOR PLOT NO-1248(P)
Project Type: Building Permission	South: Plot No. - BALDEO YADAV ETC
Nature of Development: New	East: Plot No. - OWN LAND VENDOR PLOT NO-1248(P)
Location of Development Area: Old Area	West: Road Width - 3.05M WIDE ROAD
AREA DETAILS:	
AREA OF PLOT (Minimum)	(A) 222.96 SQ.MT.
Deduction for NetPlot Area	
Road Widening Area	9.48
Total	9.48
NET AREA OF PLOT(Gross Plot Area - Deduction from Gross Plot area)	(A-Deductions) 213.48
Deduction for Balance Plot Area(from Gross Plot Area)	
Road Widening Area	9.48
Total	21.84
BALANCE AREA OF PLOT(Net Plot Area - Recreational/Amenity space)	(A-Deductions) 191.64
PLOT AREA FOR COVERAGE(Net Plot Area)	(A-Deductions) 213.48
Plot Area for FAR (Net Plot Area + RoadWidening Area)	(A-Deductions) 213.48
COVERAGE CHECK	
Permissible Coverage area (70.00 %)	149.44
Proposed Coverage Area (45.13 %)	96.35
Total Prop. Coverage Area (45.13 %)	96.35
Balance coverage area (24.87 %)	53.09
FAR CHECK	
Perm. FAR Area (1.200)	256.18
Total Perm. FAR area	256.18
Residential FAR	192.70
Proposed FAR Area	192.70
Total Proposed FAR Area	192.70
Consumed FAR (Factor)	0.90
Balance FAR Area	63.48
BUILT UP AREA CHECK	
Total Proposed BuiltUp Area	192.70
ARCHITECT (Regd)	MD SHOAB ALAM
ENGINEER (Regd)	
SUPERVISOR (Regd)	
OWNER (Regd)	WASIMA KHATUN
DEVELOPMENT AUTHORITY	LOCAL BODY

COLOR INDEX

PLOT BOUNDARY	Black
ABUTTING ROAD	Green
PROPOSED CONSTRUCTION	Red
COMMON PLOT	Yellow
ROAD WIDENING AREA	Blue
EXISTING (To be retained)	Blue
EXISTING (To be demolished)	Yellow

Buildingwise Floor FAR Details

Floor Name	Building Name AA (WASIMA KHATUN)		Total	
	Proposed Built Up Area (Sq.mt.)	Proposed FAR Area (Sq.mt.)	Total Proposed Built Up Area (Sq.mt.)	Total FAR Area (Sq.mt.)
Ground Floor	96.35	96.35	96.35	96.35
First Floor	96.35	96.35	96.35	96.35
Terrace Floor	0.00	0.00	0.00	0.00
Total :	192.70	192.70	192.70	192.70

Building USE/SUBUSE Details

Building Name	Building Use	Building SubUse	Building Structure
AA (WASIMA KHATUN)	Residential	Bungalow/ Dwelling / Non Apartment	Non-Highrise

LTP NAME AND SIGNATURE	STRUCTURAL ENG'S NAME AND SIGNATURE	BUILDER NAME AND SIGNATURE	DIGITAL SIGNATURE
MD SHOAB ALAM JNP/ENG/0001/2017			

Proposal Basic Information	
Proposal File No.	JNP/IBP/0005/W06/2023
Owner Name	WASIMA KHATUN
Khata No	82
Plot No	1248
Village Name	Asana
Use	Residential
SubUse	Bungalow/ Dwelling / Non Apartment

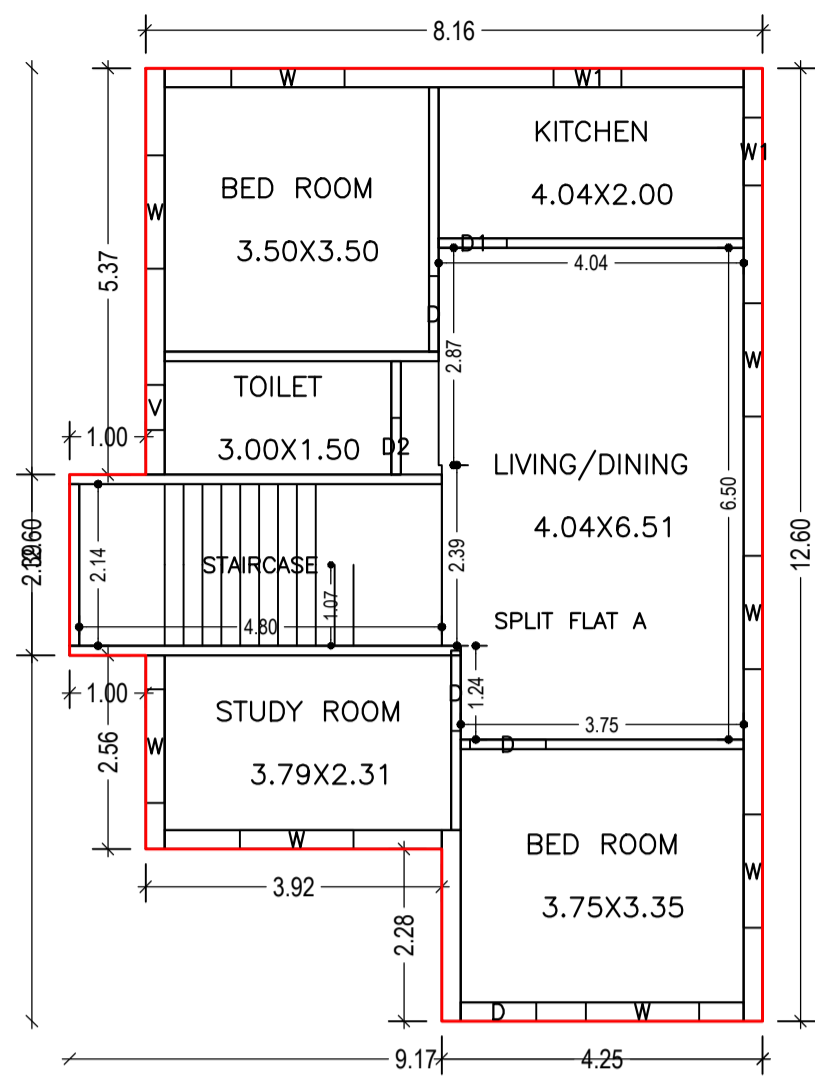

GROUND FLOOR PLAN
(Proposed)
(SCALE 1:100)

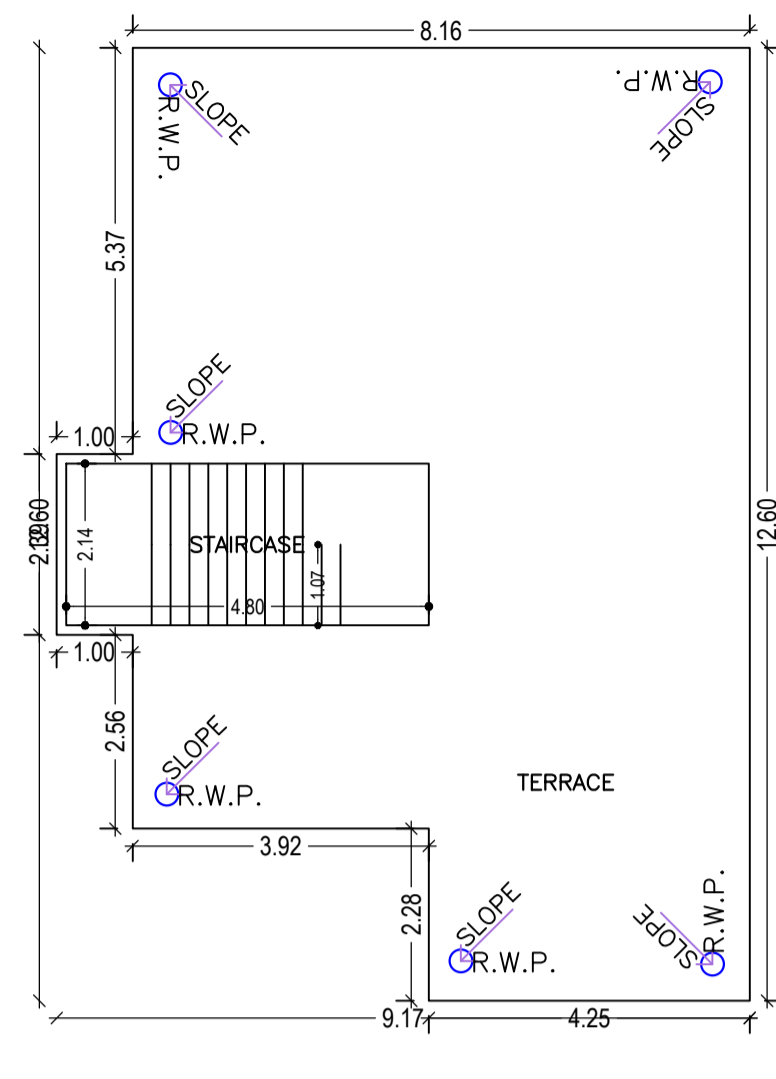

TERRACE FLOOR PLAN
(SCALE 1:100)

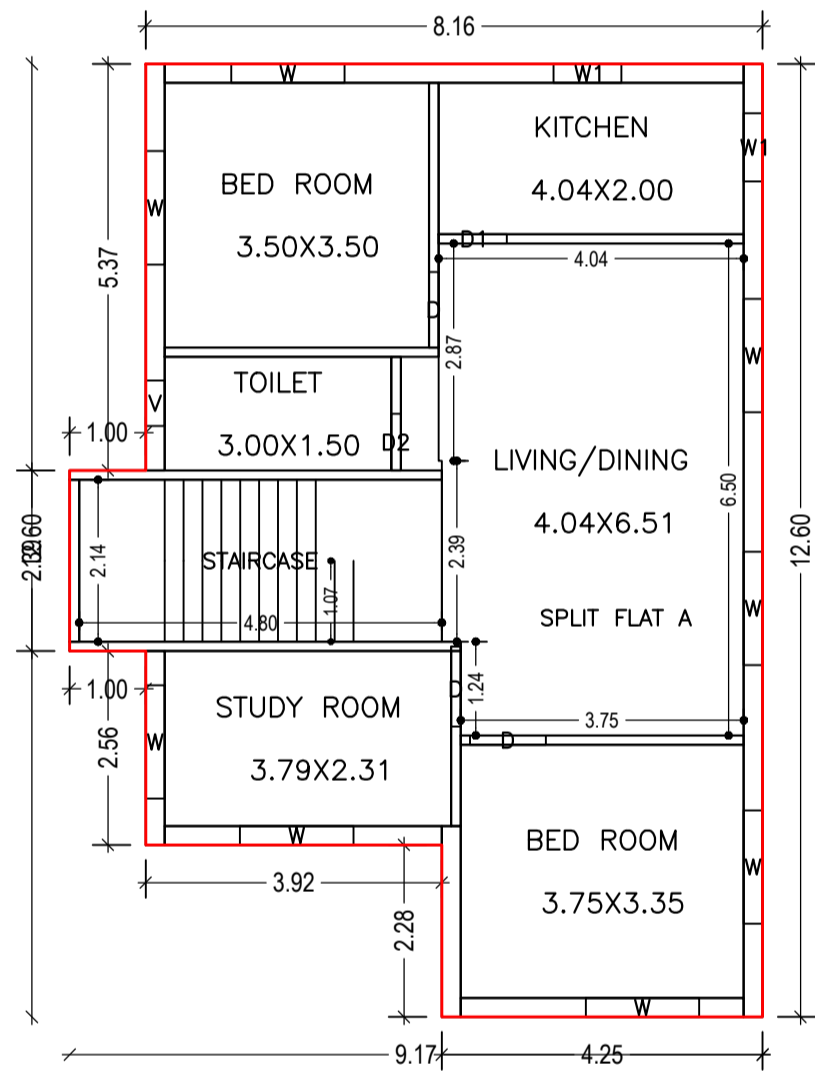

FIRST FLOOR PLAN
(Proposed)
(SCALE 1:100)

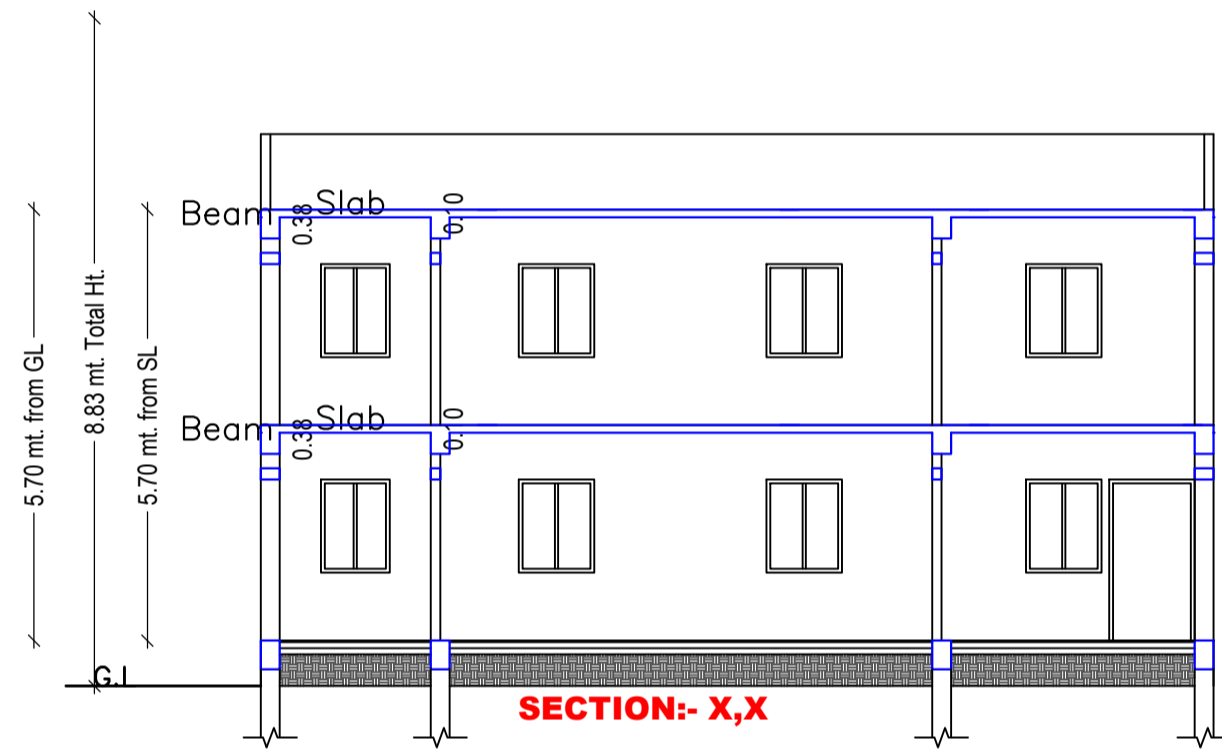

SECTION:- X,X

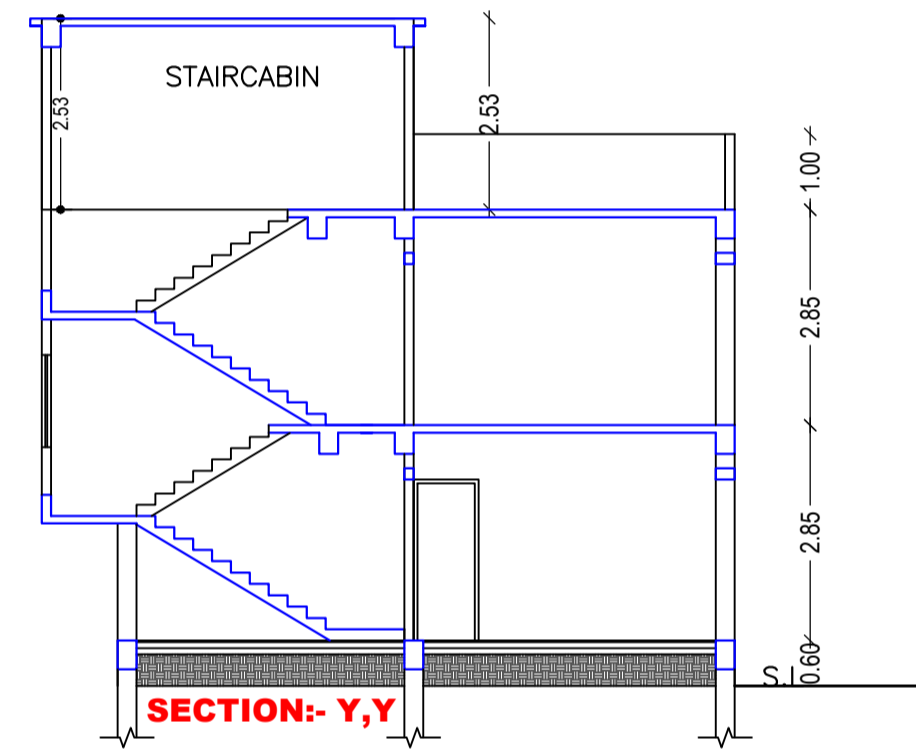

SECTION:- Y,Y

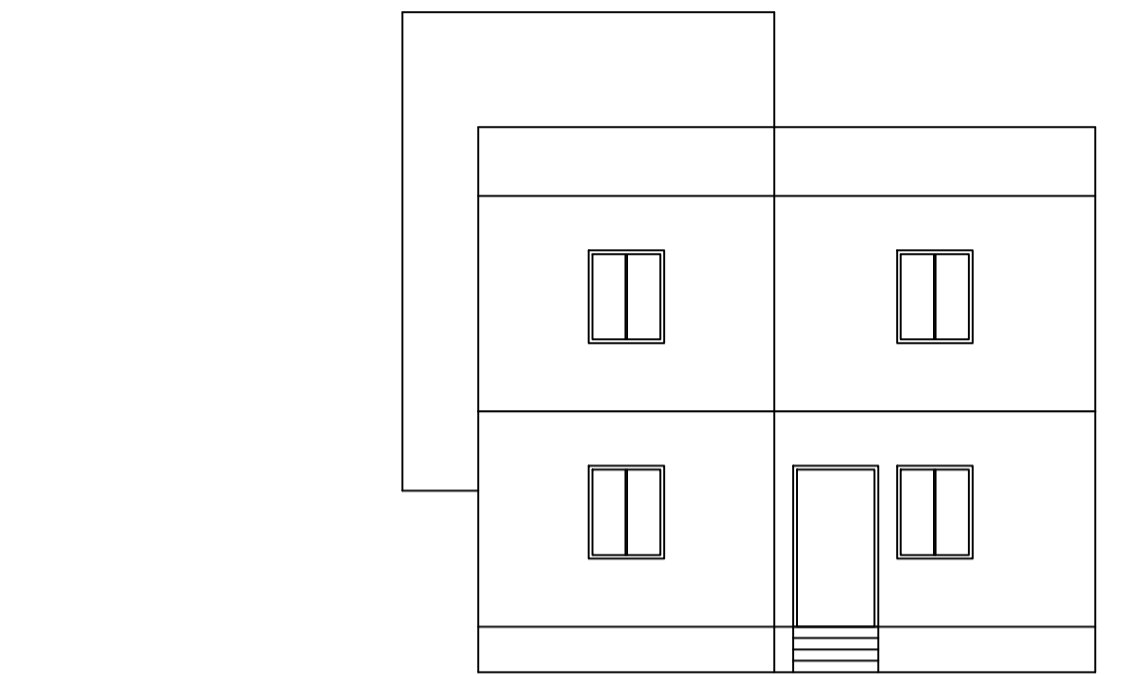

FRONT ELEVATION

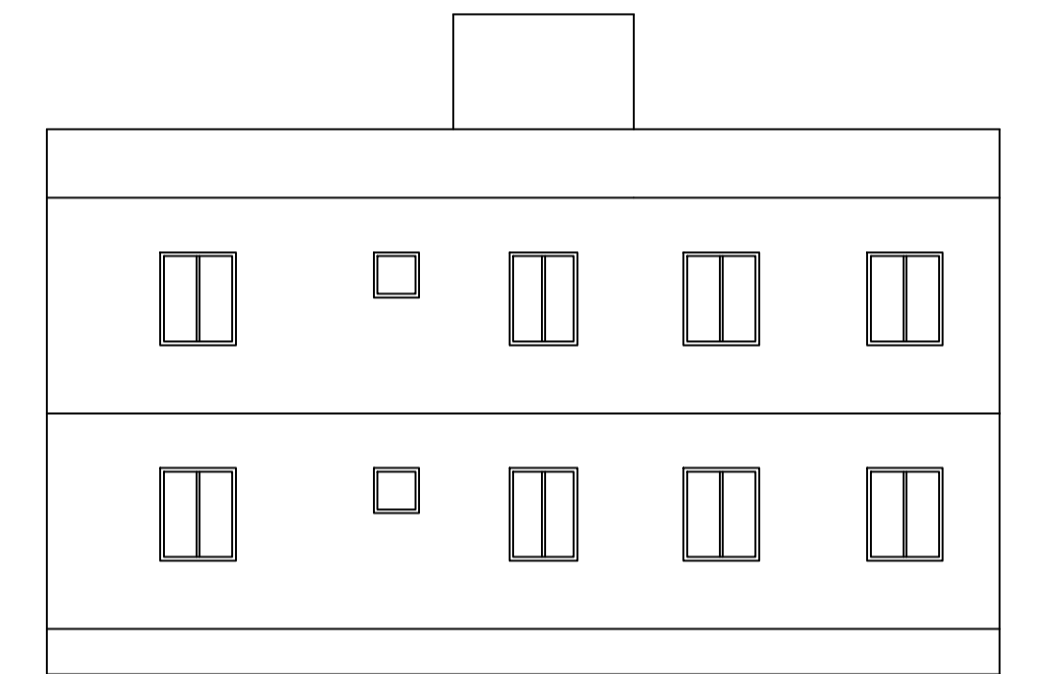

EAST SIDE ELEVATION
SCALE :- 1=100

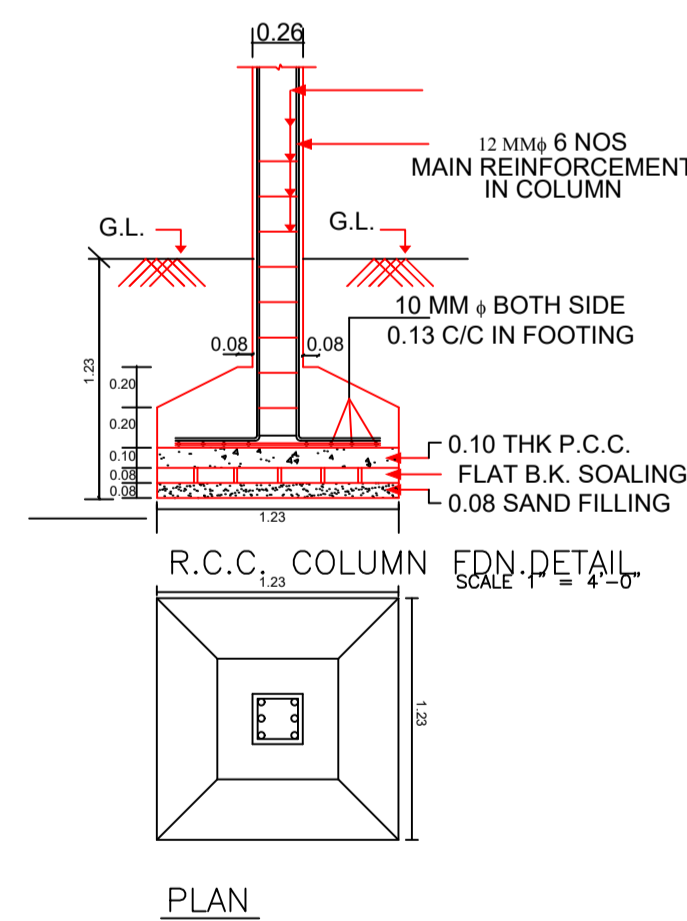

PLAN

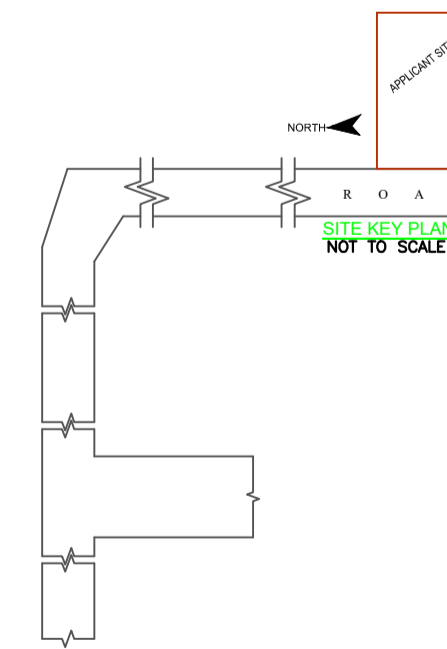
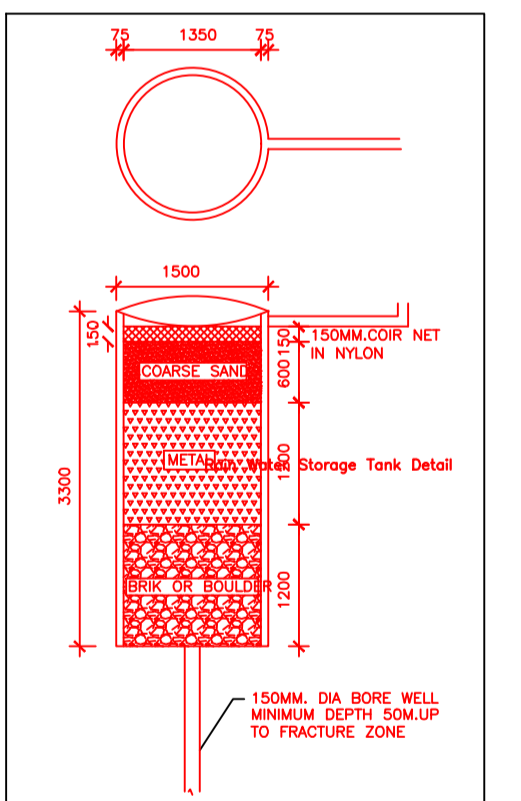
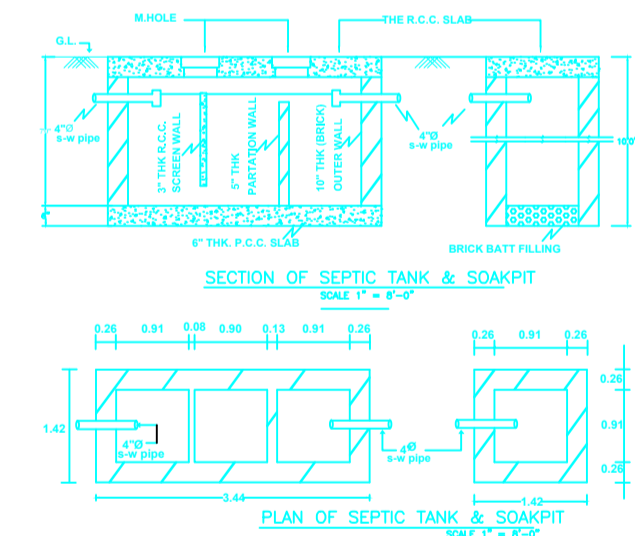

Building :AA (WASIMA KHATUN)

Floor Name	Total Built Up Area (Sq.mt.)	Proposed FAR Area (Sq.mt.)	Total FAR Area (Sq.mt.)	Total Consumed Additional FAR Area (Sq.mt.)	Tnmt (No.)
Ground Floor	96.35	96.35	96.35	96.35	01
First Floor	96.35	96.35	96.35	96.35	00
Terrace Floor	0.00	0.00	0.00	0.00	00
Total:	192.70	192.70	192.70	192.70	01
Total Number of Same Buildings	1				
Total:	192.70	192.70	192.70	192.70	01

SCHEDULE OF DOOR:

BUILDING NAME	NAME	LENGTH	HEIGHT	NOS
AA (WASIMA KHATUN)	D2	0.75	2.10	02
AA (WASIMA KHATUN)	D1	0.90	2.10	02
AA (WASIMA KHATUN)	D	1.00	2.10	07

SCHEDULE OF WINDOW/VENTILATION:

BUILDING NAME	NAME	LENGTH	HEIGHT	NOS
AA (WASIMA KHATUN)	V	0.60	0.60	02
AA (WASIMA KHATUN)	W1	0.90	1.20	04
AA (WASIMA KHATUN)	W	1.50	1.20	16

UnitBUA Table for Building :AA (WASIMA KHATUN)

FLOOR	Name	UnitBUA Type	UnitBUA Area	Carpet Area	No. of Rooms	No. of Tenement
GROUND FLOOR PLAN	SPLIT FLAT A	FLAT	150.05	145.94	6	1
FIRST FLOOR PLAN	SPLIT FLAT A	FLAT	0.00	0.00	6	0
Total:	-	-	150.05	145.94	12	1

LTP NAME AND SIGNATURE	STRUCTURAL ENG'S NAME AND SIGNATURE	BUILDER NAME AND SIGNATURE	DIGITAL SIGNATURE
MD SHOAIB ALAM JNP/ENG/001/2017			