

SITE PLAN  
SCALE :- 1=100

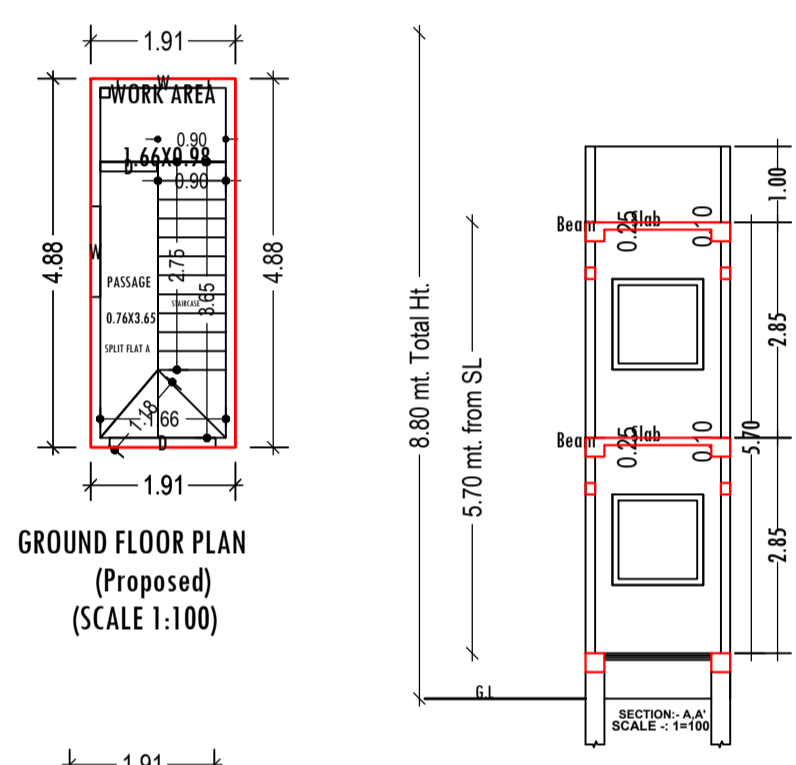

GROUND FLOOR PLAN  
(Proposed)  
SCALE 1:100

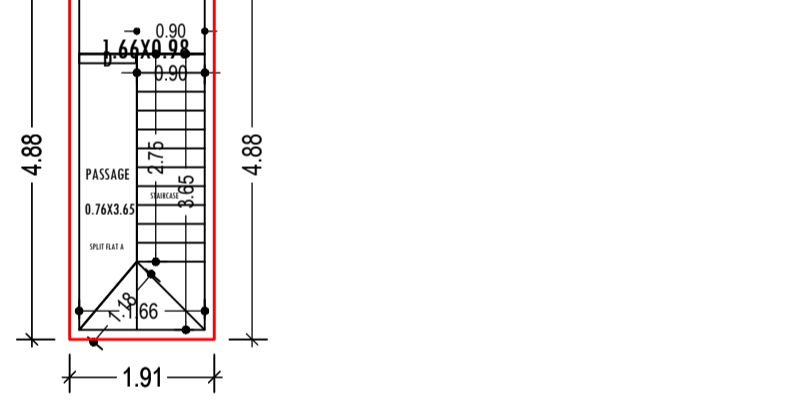

FIRST FLOOR PLAN  
(Proposed)  
SCALE 1:100

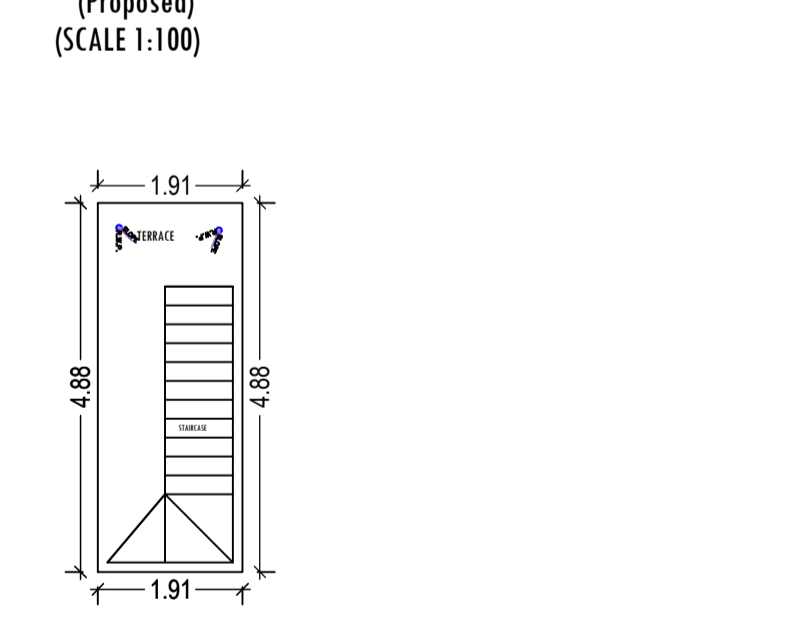

TERRACE FLOOR PLAN  
(SCALE 1:100)

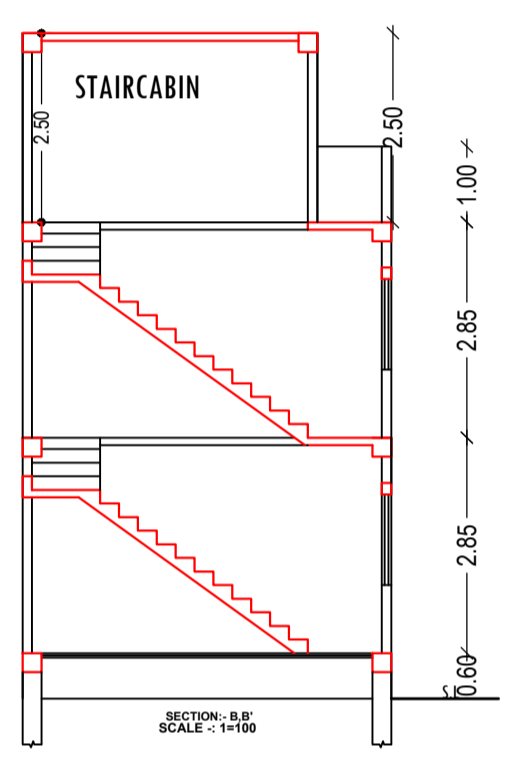

SECTION-B-B  
SCALE :- 1=100

**Building :AA (SRI MISHRI PRASAD BARNWAL)**

Floor Name	Total Built Up Area (Sq.mt.)	Proposed FAR Area (Sq.mt.)	Total FAR Area (Sq.mt.)	Total Consumed Additional FAR Area (Sq.mt.)	Tnmt (No.)
Ground Floor	9.33	9.33	9.33	9.33	01
First Floor	9.33	9.33	9.33	9.33	00
Terrace Floor	0.00	0.00	0.00	0.00	00
<b>Total :</b>	<b>18.66</b>	<b>18.66</b>	<b>18.66</b>	<b>18.66</b>	<b>01</b>
Total Number of Same Buildings	1				
<b>Total :</b>	<b>18.66</b>	<b>18.66</b>	<b>18.66</b>	<b>18.66</b>	<b>01</b>

**SCHEDULE OF DOOR:**

BUILDING NAME	NAME	LENGTH	HEIGHT	NOS
AA (SRI MISHRI PRASAD BARNWAL)	D	0.75	2.10	02

**SCHEDULE OF WINDOW/VENTILATION:**

BUILDING NAME	NAME	LENGTH	HEIGHT	NOS
AA (SRI MISHRI PRASAD BARNWAL)	W	1.20	1.20	03

**UnitBUA Table for Building :AA (SRI MISHRI PRASAD BARNWAL)**

FLOOR	Name	UnitBUA Type	UnitBUA Area	Carpet Area	No. of Rooms	No. of Tenement
GROUND FLOOR PLAN	SPLIT FLAT A	FLAT	8.13	8.10	2	1
FIRST FLOOR PLAN	SPLIT FLAT A	FLAT	0.00	0.00	2	0
<b>Total:</b>	-	-	<b>8.13</b>	<b>8.10</b>	<b>4</b>	<b>1</b>

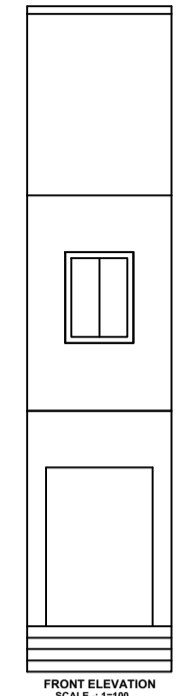

FRONT ELEVATION  
SCALE :- 1=100

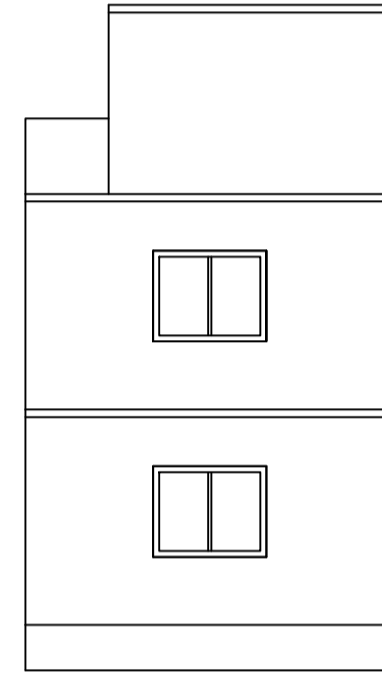

SIDE ELEVATION  
SCALE :- 1=100

AREA STATEMENT		VERSION NO.: 1.0.66
JHUMRITILAIYA NAGAR PARISHAD		VERSION DATE: 16/10/2020
PROJECT DETAIL:		
Region: JHARKHAND URBAN	Plot Use: Residential	
LOCAL BODIES	Plot SubUse: Bungalow/ Dwelling / Non Apartment	
District: KODERMA	PlotNearby/ReligiousStructure: NA	
Authority: JHUMRITILAIYA NAGAR PARISHAD	Plot/Plot No: 7459	
Inward_No: JNP/BP/0096/W10/2023	North: Plot No. - BLOCK NO. 16	
Application Type: General Proposal	South: Plot No. - BLOCK NO.18 LAND OF UDAY JALAN & KISHAN JALAN	
Project Type: Building Permission	East: Plot No. - LAND OF BHANA KHAP MICA MINING COMPANY	
Nature of Development: New	West: Road Width - 1.83M WIDE ROAD	
Location of Development Area: Old Area		
AREA DETAILS:		
AREA OF PLOT (Minimum)	(A)	SQ.MT. 28.77
Deduction for NetPlot Area		
Road Widening Area		5.12
Total		5.12
NET AREA OF PLOT(Gross Plot Area - Deduction from Gross Plot area)		
(A-Deductions)		23.65
Deduction for Balance Plot Area(from Gross Plot Area)		
Road Widening Area		5.12
Common Plot		4.24
Total		9.36
BALANCE AREA OF PLOT(Net Plot Area - Recreational/Amenity space)		
(A-Deductions)		19.41
PLOT AREA FOR COVERAGE(Net Plot Area)		
(A-Deductions)		23.65
Plot Area for FAR (Net Plot Area + RoadWidening Area)		
(A-Deductions)		23.65
COVERAGE CHECK		
Permissible Coverage area ( 70.00 % )		16.56
Proposed Coverage Area ( 39.45 % )		9.33
Total Prop. Coverage Area ( 39.45 % )		9.33
Balance coverage area ( 30.57 % )		7.23
FAR CHECK		
Perm. FAR Area ( 1.200 )		28.38
Total Perm. FAR area		28.38
Residential FAR		18.65
Proposed FAR Area		18.65
Total Proposed FAR Area		18.65
Consumed FAR (Factor)		0.79
Balance FAR Area		9.73
BUILT UP AREA CHECK		
Total Proposed BuiltUp Area		18.66
ARCHITECT (Regd)	MD SHOAB ALAM	
ENGINEER (Regd)		
SUPERVISOR (Regd)		
OWNER (Regd)	SRI MISHRI PRASAD BARNWAL	
DEVELOPMENT AUTHORITY		LOCAL BODY

**COLOR INDEX**

PLOT BOUNDARY	Black
ABUTTING ROAD	Red
PROPOSED CONSTRUCTION	Green
COMMON PLOT	Yellow
ROAD WIDENING AREA	Blue
EXISTING (To be retained)	Orange
EXISTING (To be demolished)	Grey

**Buildingwise Floor FAR Details**

Floor Name	Building Name		Total	
	AA (SRI MISHRI PRASAD BARNWAL)	Proposed FAR Area (Sq.mt.)	Total Proposed Built Up Area (Sq.mt.)	Total FAR Area (Sq.mt.)
Ground Floor	9.33	9.33	9.33	9.33
First Floor	9.33	9.33	9.33	9.33
Terrace Floor	0.00	0.00	0.00	0.00
<b>Total :</b>	<b>18.66</b>	<b>18.66</b>	<b>18.66</b>	<b>18.66</b>

**Building USE/SUBUSE Details**

Building Name	Building Use	Building SubUse	Building Structure
AA (SRI MISHRI PRASAD BARNWAL)	Residential	Bungalow/ Dwelling / Non Apartment	Non-Highrise

**FAR & Tenement Details (Table 4c-1)**

Building	No. of Same Bldg	Total Built Up Area (Sq.mt.)	Proposed FAR Area (Sq.mt.)	Total FAR Area (Sq.mt.)	Total Consumed Additional FAR Area (Sq.mt.)	Tnmt (No.)
AA (SRI MISHRI PRASAD BARNWAL)	1	18.66	18.66	18.66	18.66	01
<b>Grand Total :</b>	<b>1</b>	<b>18.66</b>	<b>18.66</b>	<b>18.66</b>	<b>18.66</b>	<b>01</b>

