

SITE PLAN
 SCALE :- 1=100

SITE PLAN

AREA STATEMENT		VERSION NO. : 1.0.66
JHUMRITILAIYA NAGAR PARISHAD		VERSION DATE: 16/10/2020
PROJECT DETAIL:		
Region: JHARKHAND URBAN LOCAL BODIES	Plot Use: Residential	
District: KODERMA	Plot SubUse: Bungalow/ Dwelling / Non Apartment	
Authority: JHUMRITILAIYA NAGAR PARISHAD	PlotNearbyReligiousStructure: NA	
Inward_No: JNP/BP/0069/W19/2023	Plot/SubPlot No: 491,492	
Application Type: General Proposal	North: Plot No. - LAND OF RAMKRISHAN PRASAD PLOT NO-489	
Project Type: Building Permission	South: Road Width - 3.66M WIDE KATCHA ROAD (P. NO-492/P)	
Nature of Development: New	East: Plot No. - LAND OF DEOLAL SINGH (P.NO-488)	
Location of Development Area: Old Area	West: Road Width - 3.66M WIDE KATCHA ROAD	
AREA DETAILS:		
AREA OF PLOT (Minimum)	(A)	205.93
NET AREA OF PLOT(Gross Plot Area - Deduction from Gross Plot area)	(A-Deductions)	205.93
Deduction for Balance Plot Area(from Gross Plot Area)		
Common Plot		21.87
Total		21.87
BALANCE AREA OF PLOT(Net Plot Area - Recreational/Amenity space)	(A-Deductions)	184.06
PLOT AREA FOR COVERAGE(Net Plot Area)	(A-Deductions)	205.93
Plot Area for FAR (Net Plot Area + RoadWidening Area)	(A-Deductions)	205.93
COVERAGE CHECK		
Permissible Coverage area (70.00 %)		144.15
Proposed Coverage Area (45.70 %)		94.11
Total Prop. Coverage Area (45.7 %)		94.11
Balance coverage area (24.30 %)		50.04
FAR CHECK		
Perm. FAR Area (1.500)		308.89
Total Perm. FAR area		308.89
Residential FAR		244.29
Proposed FAR Area		244.29
Total Proposed FAR Area		244.29
Consumed FAR (Factor)		1.19
Balance FAR Area		64.60
BUILT UP AREA CHECK		
Total Proposed BuiltUp Area		282.34
ARCHITECT (Regd)		MD SHOAB ALAM
ENGINEER (Regd)		
SUPERVISOR (Regd)		
OWNER (Regd)		SMT INDU KUMARI
DEVELOPMENT AUTHORITY		LOCAL BODY

COLOR INDEX	
PLOT BOUNDARY	Black
ABUTTING ROAD	Green
PROPOSED CONSTRUCTION	Red
COMMON PLOT	Yellow
ROAD WIDENING AREA	Blue
EXISTING (To be retained)	Light Blue
EXISTING (To be demolished)	Light Yellow

Buildingwise Floor FAR Details

Floor Name	Building Name AA (SMT INDU KUMARI)		Total	
	Proposed Built Up Area (Sq.mt.)	Proposed FAR Area (Sq.mt.)	Total Proposed Built Up Area (Sq.mt.)	Total FAR Area (Sq.mt.)
Ground Floor	94.12	56.07	94.12	56.07
First Floor	94.11	94.11	94.11	94.11
Second Floor	94.11	94.11	94.11	94.11
Terrace Floor	0.00	0.00	0.00	0.00
Total :	282.34	244.29	282.34	244.29

Building USE/SUBUSE Details

Building Name	Building Use	Building SubUse	Building Structure
AA (SMT INDU KUMARI)	Residential	Bungalow/ Dwelling / Non Apartment	Non-Highrise

FAR & Tenement Details (Table 4c-1)

Building	No. of Same Bldg	Total Built Up Area (Sq.mt.)	Deductions (Area in Sq.mt.)		Proposed FAR Area (Sq.mt.)	Total FAR Area (Sq.mt.)	Total Consumed Additional FAR Area (Sq.mt.)	Tnmt (No.)
			Parking	Resi.				
AA (SMT INDU KUMARI)	1	282.34	38.05	244.29	244.29	244.29	01	
Grand Total :	1	282.34	38.05	244.29	244.29	244.29	01	

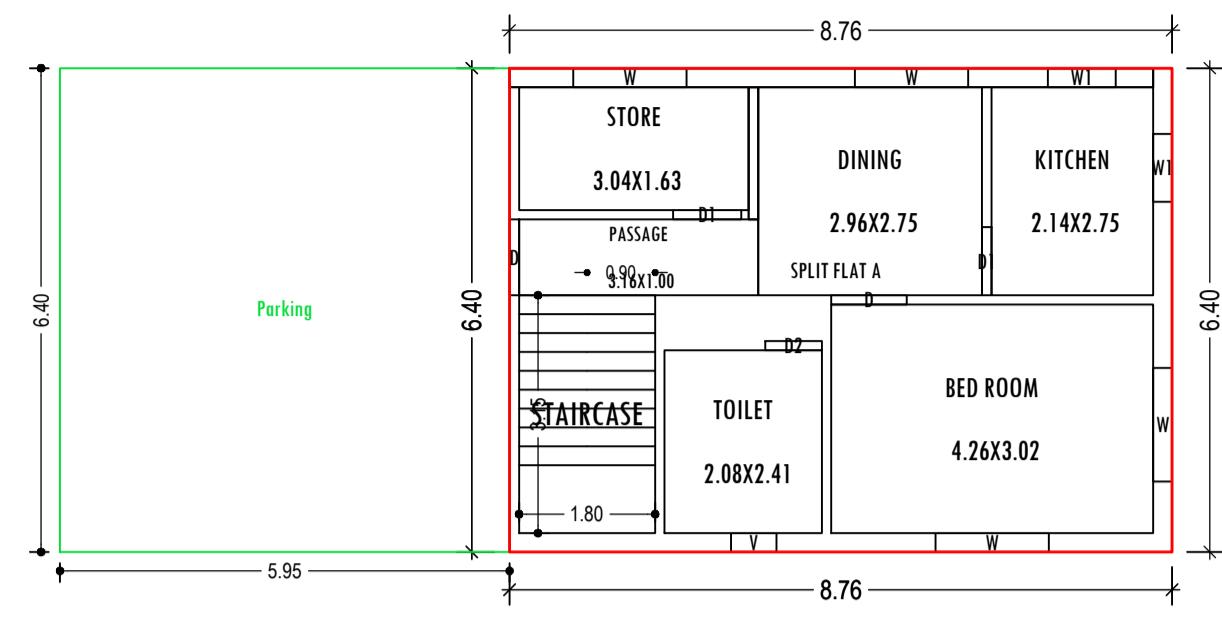
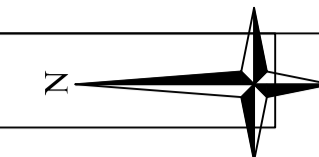

GROUND FLOOR PLAN
(Proposed)
(SCALE 1:100)

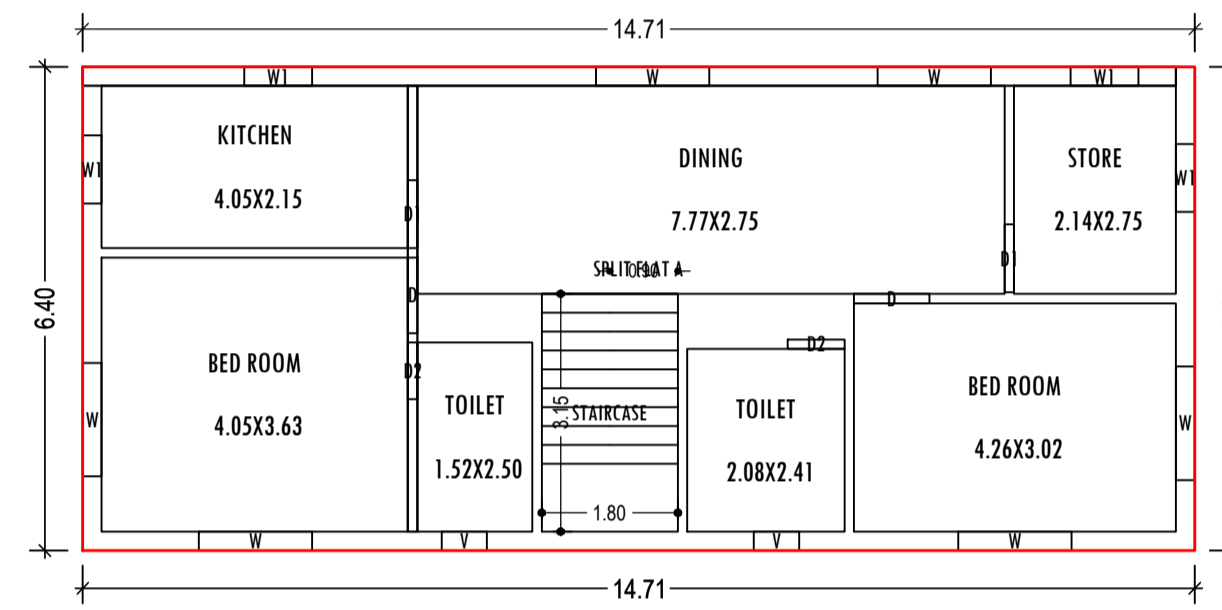

TYPICAL - 1 & 2 FLOOR PLAN
(Proposed)
(SCALE 1:100)

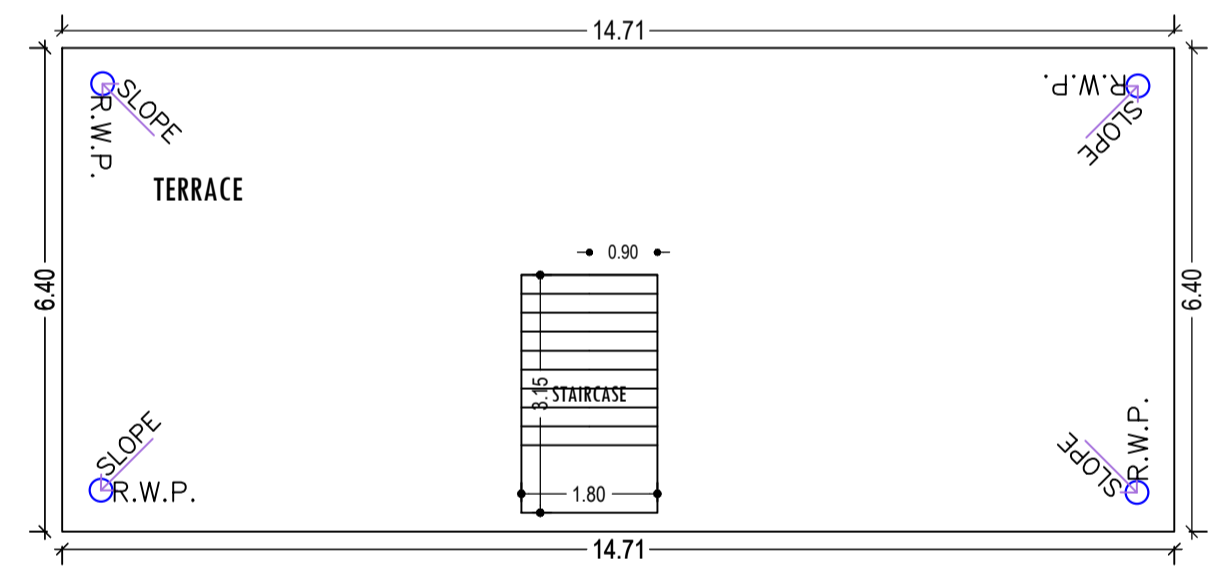

TERRACE FLOOR PLAN
(SCALE 1:100)

Building :AA (SMT INDU KUMARI)

Floor Name	Total Built Up Area (Sq.mt.)	Deductions (Area in Sq.mt.)		Proposed FAR Area (Sq.mt.)	Total FAR Area (Sq.mt.)	Total Consumed Additional FAR Area (Sq.mt.)	Trmt (No.)
		Parking	Resi.				
Ground Floor	94.12	38.05	56.07	56.07	56.07	56.07	01
First Floor	94.11	0.00	94.11	94.11	94.11	94.11	00
Second Floor	94.11	0.00	94.11	94.11	94.11	94.11	00
Terrace Floor	0.00	0.00	0.00	0.00	0.00	0.00	00
Total :	282.34	38.05	244.29	244.29	244.29	244.29	01
Total Number of Same Buildings	1						
Total :	282.34	38.05	244.29	244.29	244.29	244.29	01

SCHEDULE OF DOOR:

BUILDING NAME	NAME	LENGTH	HEIGHT	NOS
AA (SMT INDU KUMARI)	D2	0.75	2.10	05
AA (SMT INDU KUMARI)	D1	0.90	2.10	06
AA (SMT INDU KUMARI)	D	1.00	2.10	06

SCHEDULE OF WINDOW/VENTILATION:

BUILDING NAME	NAME	LENGTH	HEIGHT	NOS
AA (SMT INDU KUMARI)	V	0.60	0.60	05
AA (SMT INDU KUMARI)	W1	0.90	1.20	10
AA (SMT INDU KUMARI)	W	1.50	1.20	16

UnitBUA Table for Building :AA (SMT INDU KUMARI)

FLOOR	Name	UnitBUA Type	UnitBUA Area	Carpet Area	No. of Rooms	No. of Tenement
GROUND FLOOR PLAN	SPLIT FLAT A	FLAT	198.14	196.45	6	1
AA (SMT INDU KUMARI)	SPLIT FLAT A	FLAT	0.00	0.00	7	0
TYPICAL - 1 & 2 FLOOR PLAN	SPLIT FLAT A	FLAT	0.00	0.00	7	0
Total:	-	-	198.14	196.45	20	1

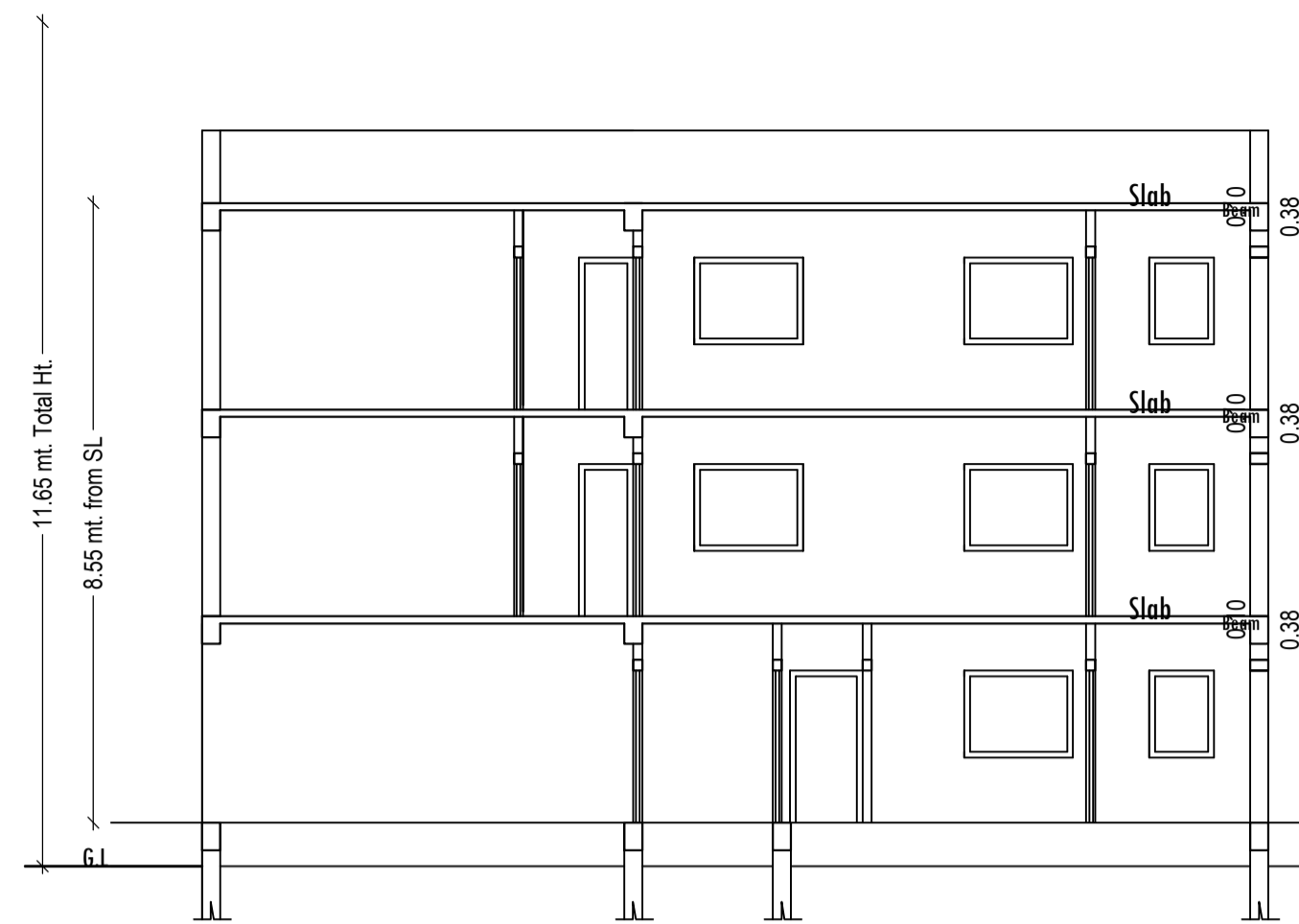

SECTION - A-A'
SCALE - 1:100

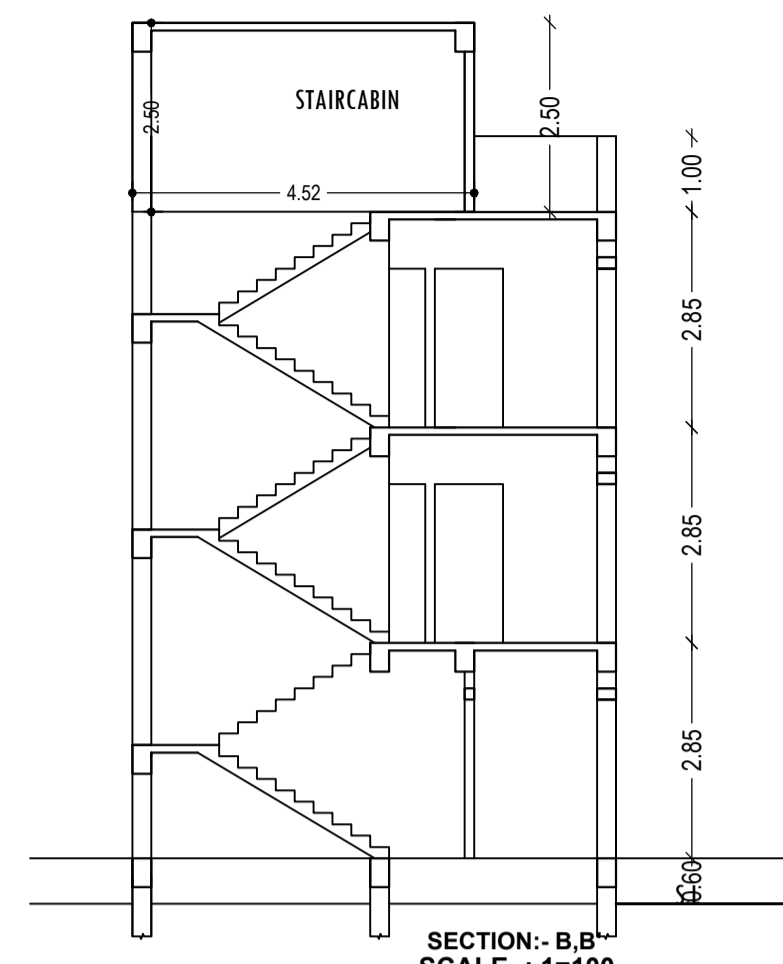

SECTION - B-B'
SCALE - 1:100

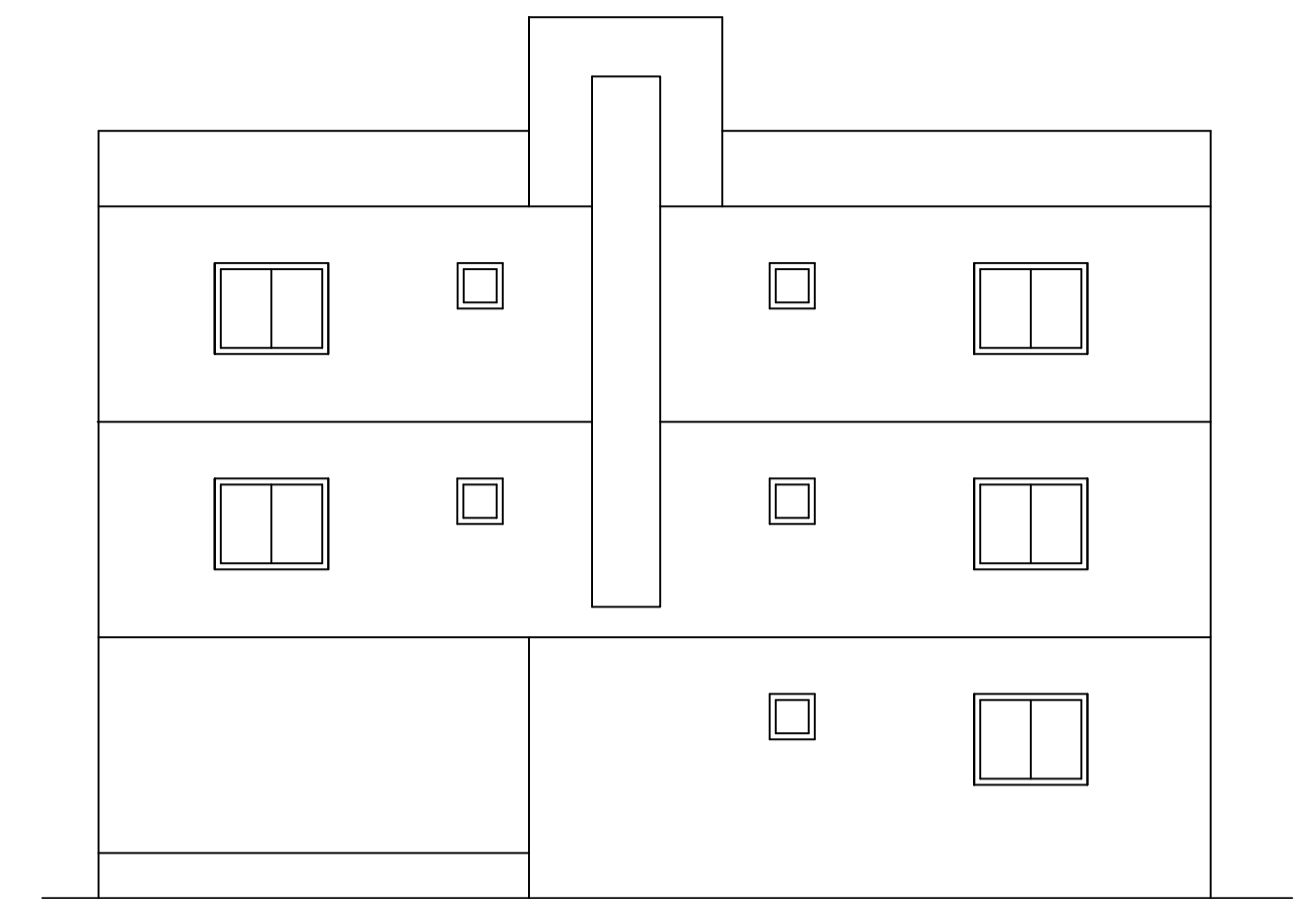

FRONT ELEVATION
SCALE - 1:100

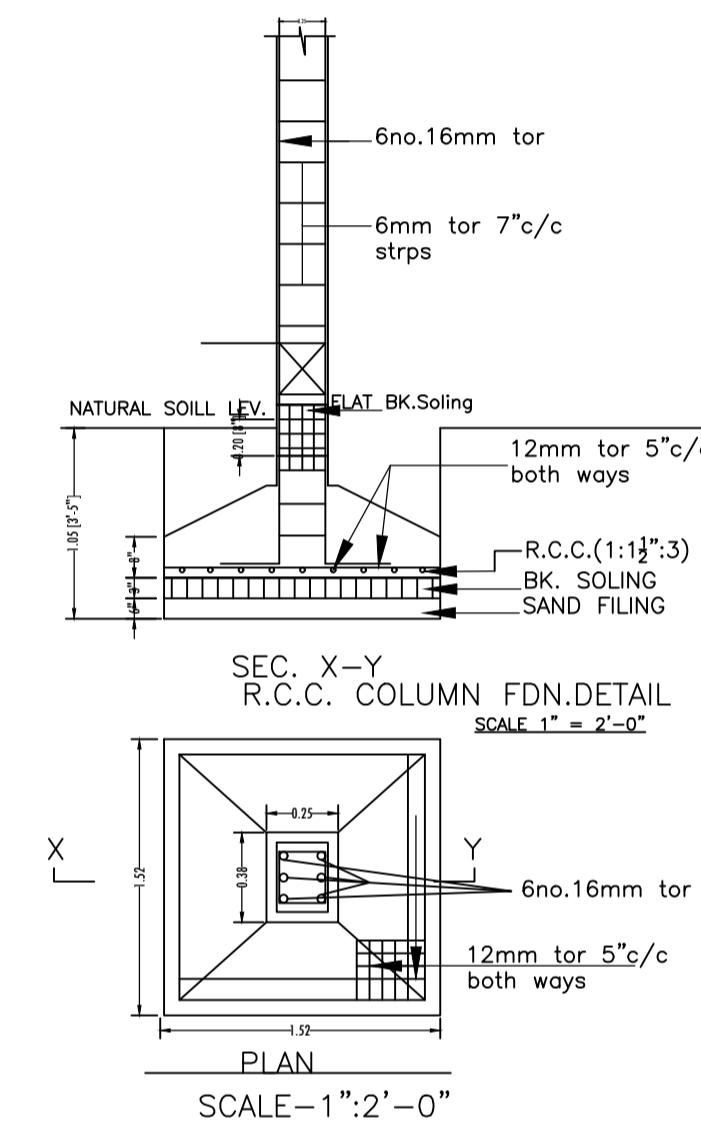

SCALE - 1"=2'-0"

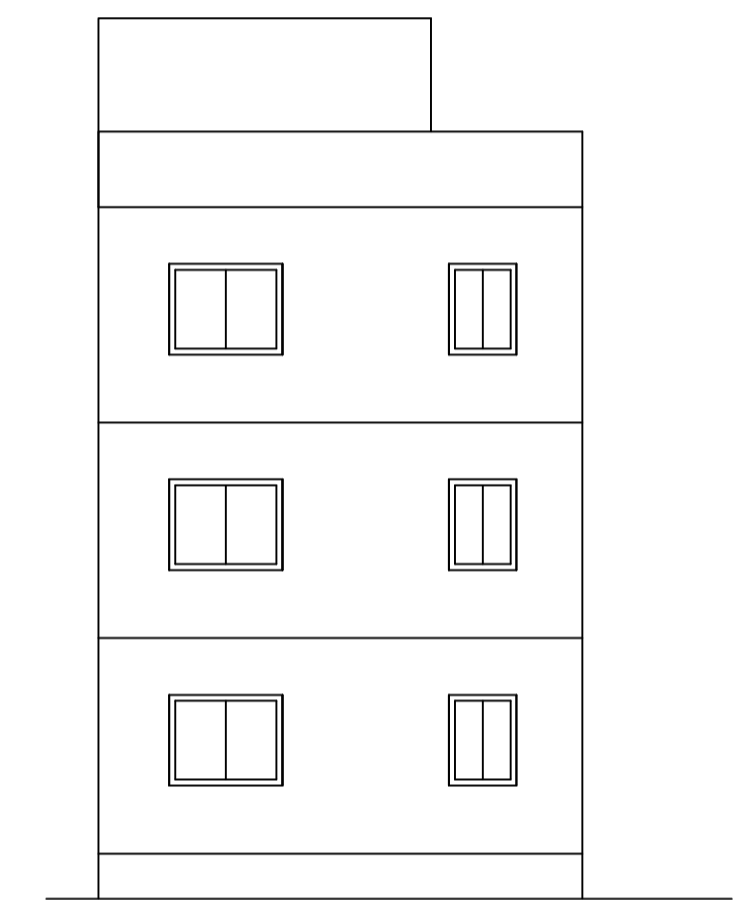

SIDE ELEVATION
SCALE - 1:100

