

FAR & Tenement Details (Table 4c-1)

Building	No. of Same Bldg	Total Built Up Area (Sq.mt.)	Proposed FAR Area (Sq.mt.) Resi.	Total FAR Area (Sq.mt.)	Total Consumed Additional FAR Area (Sq.mt.)	Trmt (No.)
AA (SMT SANGEETA BARNWAL)	1	33.12	33.12	33.12	33.12	01
Grand Total :	1	33.12	33.12	33.12	33.12	01

Proposal Basic Information

Proposal File No.	JNP/IBP/0068/W10/2023
Owner Name	SMT SANGEETA BARNWAL
Khata No	631
Plot No	7457
Village Name	Tilaiya
Use	Residential
SubUse	Bungalow/ Dwelling / Non Apartment

AREA STATEMENT	VERSION NO. : 1.0.66
JHUMRITILAIYA NAGAR PARISHAD	VERSION DATE: 16/10/2020
PROJECT DETAIL:	
Region: JHARKHAND URBAN LOCAL BODIES	Plot Use: Residential
District: KODERMA	Plot SubUse: Bungalow/ Dwelling / Non Apartment
Authority: JHUMRITILAIYA NAGAR PARISHAD	PlotNearbyReligiousStructure: NA
Inward No: JNP/IBP/0068/W10/2023	PlotSubPlot No: 7457
Application Type: General Proposal	North: Plot No. - LAND OF SANTOSH KUMAR
Project Type: Building Permission	South: Plot No. - LAND OF SUSHANT KUMAR
Nature of Development: New	East: Plot No. - LAND OF ASHOK KUMAR BARNWAL
Location of Development Area: Old Area	West: Road Width - 4.57M WIDE ROAD
AREA DETAILS:	
AREA OF PLOT (Minimum)	(A) 23.42
NET AREA OF PLOT(Gross Plot Area - Deduction from Gross Plot area)	(A-Deductions) 23.42
Deduction for Balance Plot Area(from Gross Plot Area)	
Common Plot	2.19
BALANCE AREA OF PLOT(Net Plot Area - Recreational/Amenity space)	(A-Deductions) 21.23
PLOT AREA FOR COVERAGE(Net Plot Area)	(A-Deductions) 23.42
Plot Area for FAR (Net Plot Area + RoadWidening Area)	(A-Deductions) 23.42
COVERAGE CHECK	
Permissible Coverage area (70.00 %)	16.39
Proposed Coverage Area (47.14 %)	11.04
Total Prop. Coverage Area (47.14 %)	11.04
Balance coverage area (22.84 %)	5.35
FAR CHECK	
Perm. FAR Area (1.500)	35.13
Total Perm. FAR area	35.13
Residential FAR	33.12
Proposed FAR Area	33.12
Total Proposed FAR Area	33.12
Consumed FAR (Factor)	1.41
Balance FAR Area	2.01
BUILT UP AREA CHECK	
Total Proposed BuiltUp Area	33.12
ARCHITECT (Regd)	MD SHOAB ALAM
ENGINEER (Regd)	
SUPERVISOR (Regd)	
OWNER (Regd)	SMT SANGEETA BARNWAL
DEVELOPMENT AUTHORITY	LOCAL BODY

COLOR INDEX	
PLOT BOUNDARY	Black
ABUTTING ROAD	Green
PROPOSED CONSTRUCTION	Red
COMMON PLOT	Yellow
ROAD WIDENING AREA	Yellow
EXISTING (To be retained)	Blue
EXISTING (To be demolished)	Yellow

Buildingwise Floor FAR Details

Floor Name	Building Name		Total	
	Proposed Built Up Area (Sq.mt.)	Proposed FAR Area (Sq.mt.)	Total Proposed Built Up Area (Sq.mt.)	Total FAR Area (Sq.mt.)
Basement Floor	11.04	11.04	11.04	11.04
Ground Floor	11.04	11.04	11.04	11.04
First Floor	11.04	11.04	11.04	11.04
Terrace Floor	0.00	0.00	0.00	0.00
Total :	33.12	33.12	33.12	33.12

Building USE/SUBUSE Details

Building Name	Building Use	Building SubUse	Building Structure
AA (SMT SANGEETA BARNWAL)	Residential	Bungalow/ Dwelling / Non Apartment	Non-Highrise

LTP NAME AND SIGNATURE	STRUCTURAL ENG'S NAME AND SIGNATURE	BUILDER NAME AND SIGNATURE	DIGITAL SIGNATURE
MD SHOAB ALAM JNP/ENG/0001/2017			

Proposal Basic Information

Proposal File No.	JNP/BP/0068/W10/2023
Owner Name	SMT SANGEETA BARNWAL
Khata No	631
Plot No	7457
Village Name	Tilaiya
Use	Residential
SubUse	Bungalow/ Dwelling / Non Apartment

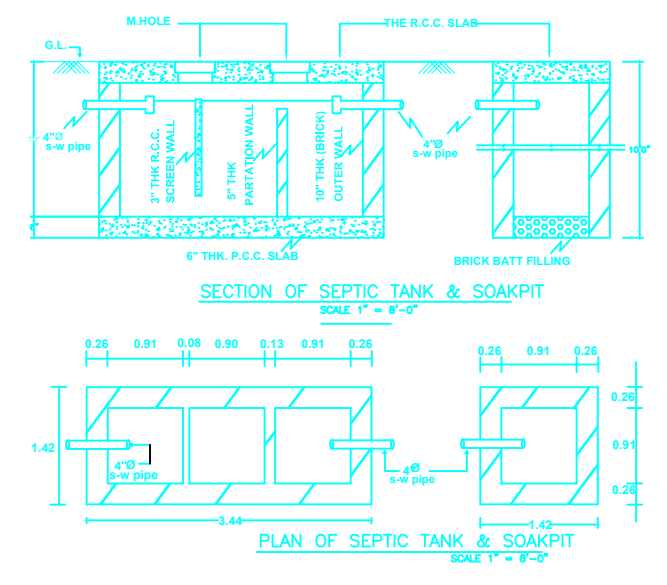
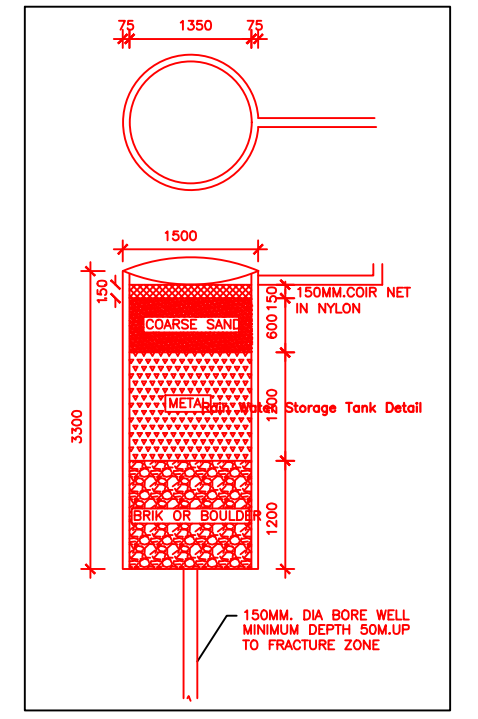
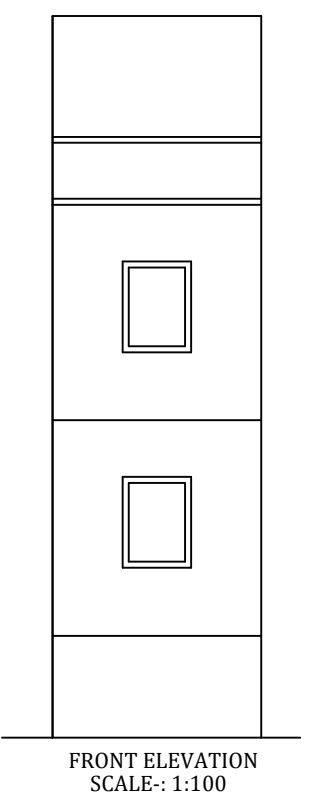
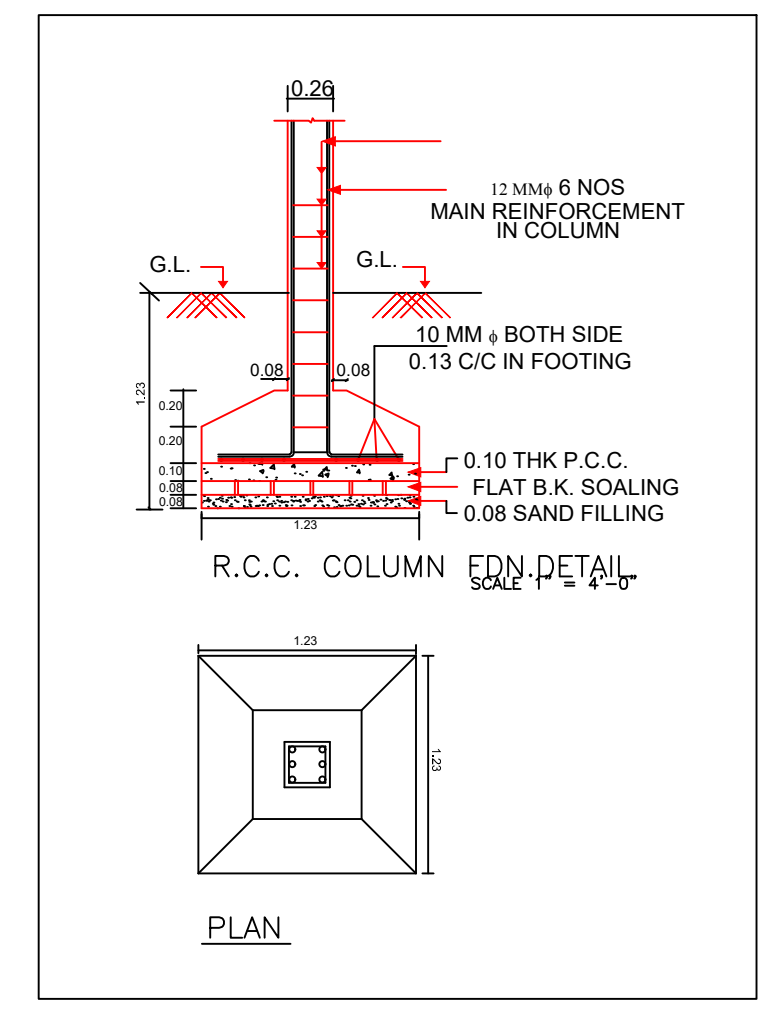
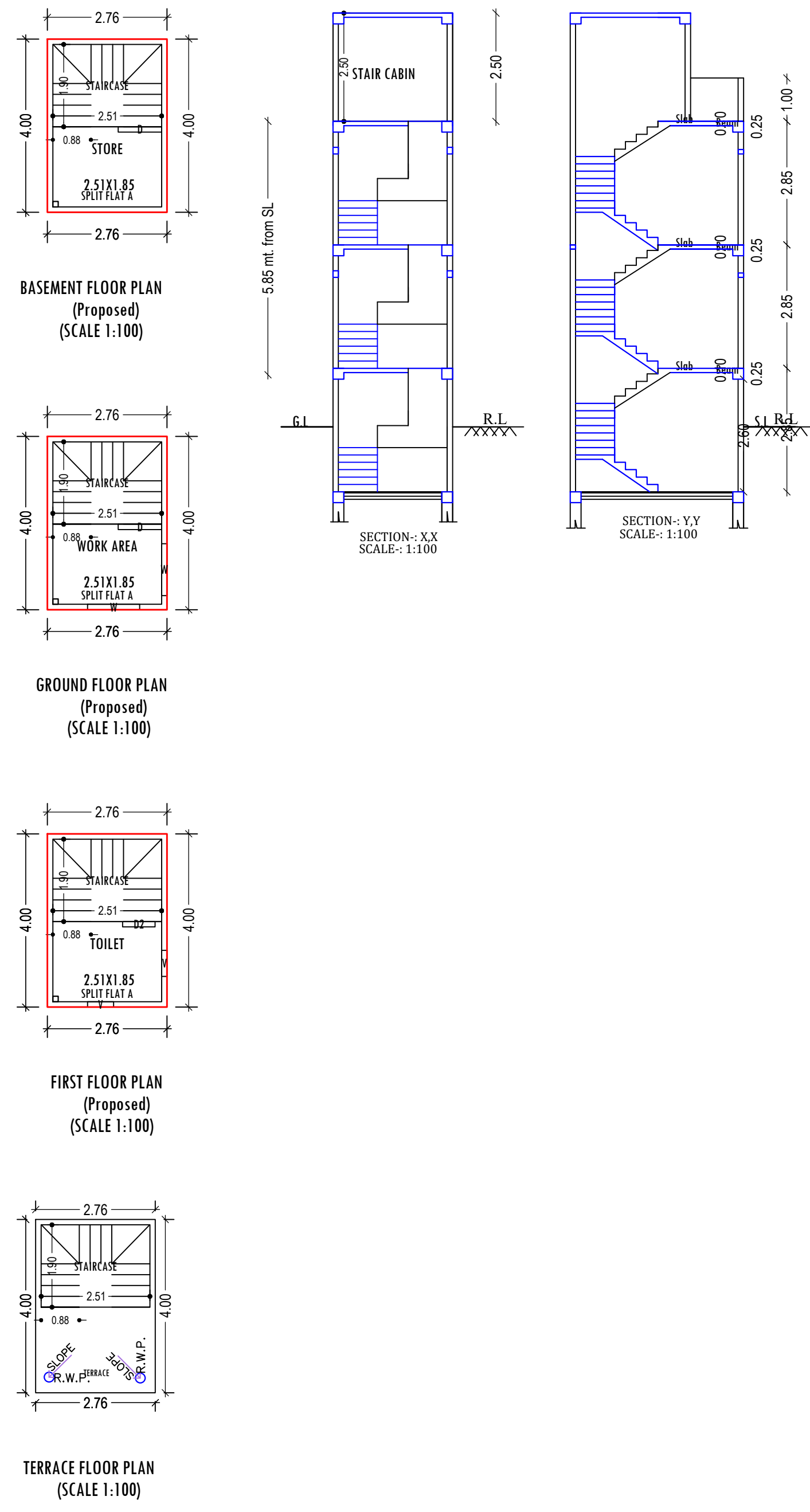

Building -AA (SMT SANGEETA BARNWAL)

Floor Name	Total Built Up Area (Sq.mt.)	Proposed FAR Area (Sq.mt.) Resi.	Total FAR Area (Sq.mt.)	Total Consumed Additional FAR Area (Sq.mt.)	Tnmt (No.)
Basement Floor	11.04	11.04	11.04	11.04	01
Ground Floor	11.04	11.04	11.04	11.04	00
First Floor	11.04	11.04	11.04	11.04	00
Terrace Floor	0.00	0.00	0.00	0.00	00
Total:	33.12	33.12	33.12	33.12	01
Total Number of Same Buildings	1				
Total:	33.12	33.12	33.12	33.12	01

SCHEDULE OF DOOR:

BUILDING NAME	NAME	LENGTH	HEIGHT	NOS
AA (SMT SANGEETA BARNWAL)	D2	0.75	2.10	01
AA (SMT SANGEETA BARNWAL)	D	1.00	2.10	02

SCHEDULE OF WINDOW/VENTILATION:

BUILDING NAME	NAME	LENGTH	HEIGHT	NOS
AA (SMT SANGEETA BARNWAL)	V	0.60	0.60	02
AA (SMT SANGEETA BARNWAL)	W	1.20	1.20	02

UnitBUA Table for Building -AA (SMT SANGEETA BARNWAL)

FLOOR	Name	UnitBUA Type	UnitBUA Area	Carpet Area	No. of Rooms	No. of Tenement
BASEMENT FLOOR PLAN	SPLIT FLAT A	FLAT	13.93	13.88	1	1
GROUND FLOOR PLAN	SPLIT FLAT A	FLAT	0.00	0.00	1	0
FIRST FLOOR PLAN	SPLIT FLAT A	FLAT	0.00	0.00	1	0
Total:	-	-	13.93	13.88	3	1

LTP NAME AND SIGNATURE	STRUCTURAL ENG'S NAME AND SIGNATURE	BUILDER NAME AND SIGNATURE	DIGITAL SIGNATURE
MD SHOAIB ALAM JNP/ENG/0001/2017			



Proposal Basic Information	
Proposal File No.	JNP/EP/0068/W10/2023
Owner Name	SMT SANGEETA BARNWAL
Khata No	631
Plot No	7457
Village Name	Tilaiya
Use	Residential
SubUse	Bungalow/ Dwelling / Non Apartment

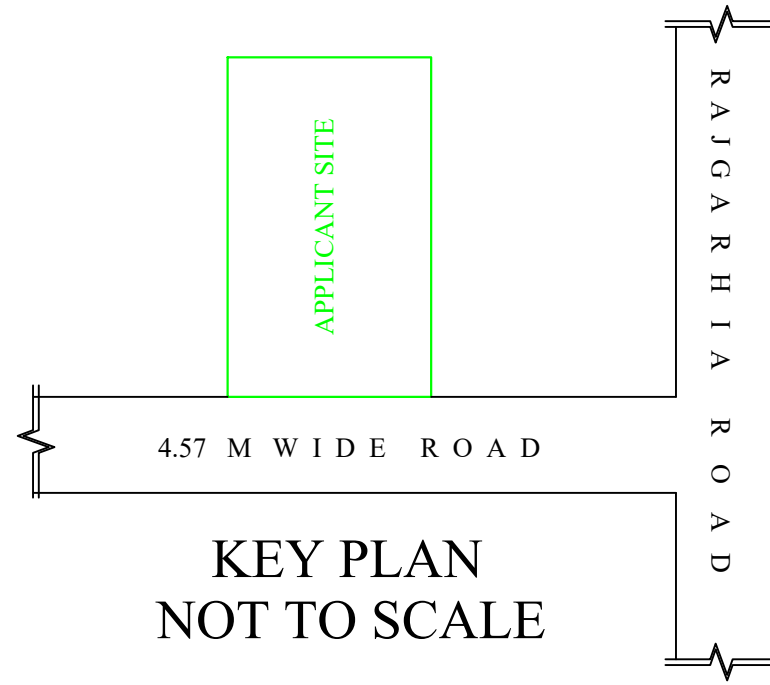

LTP NAME AND SIGNATURE	STRUCTURAL ENG'S NAME AND SIGNATURE	BUILDER NAME AND SIGNATURE	DIGITAL SIGNATURE
MD. SHOAB ALAM JNP/ENG/0001/2017			