

Proposal Basic Information	
Proposal File No.	JNP/IBP/0067/W10/2023
Owner Name	1 SRI SHAMBHU PRASAD BARNWAL 2 SMT KHUSHBU
Khata No	631
Plot No	7457
Village Name	Tilaiya
Use	Residential
SubUse	Bungalow/ Dwelling / Non Apartment

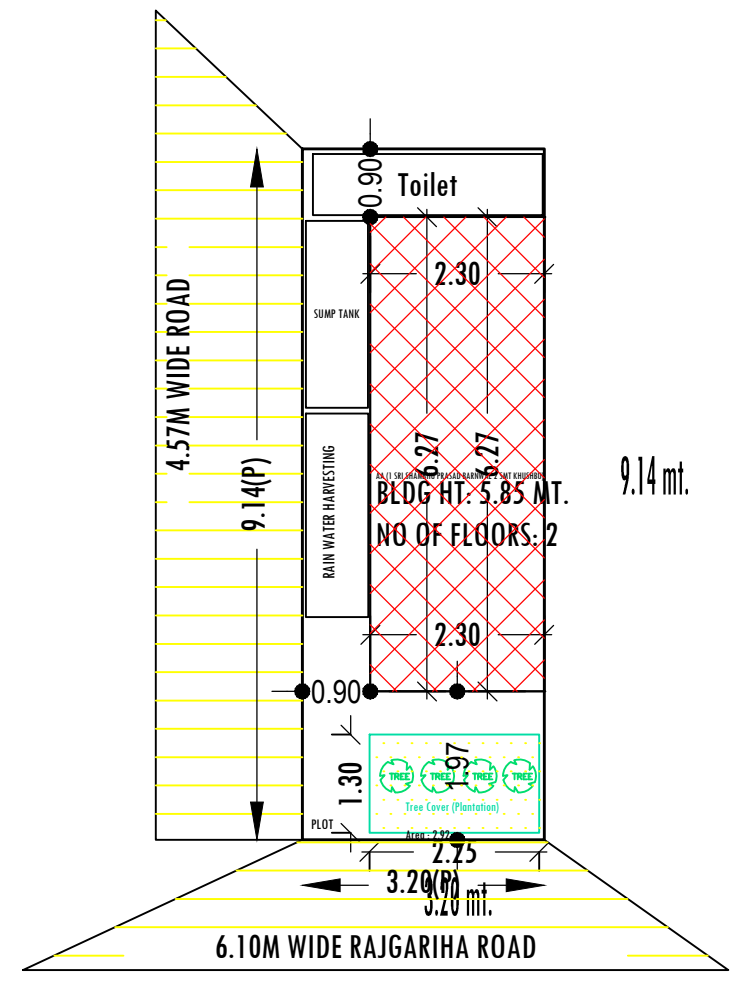

SITE PLAN

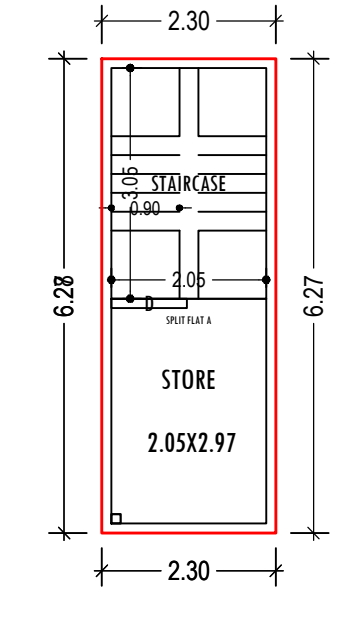

BASEMENT FLOOR PLAN (Proposed) (SCALE 1:100)

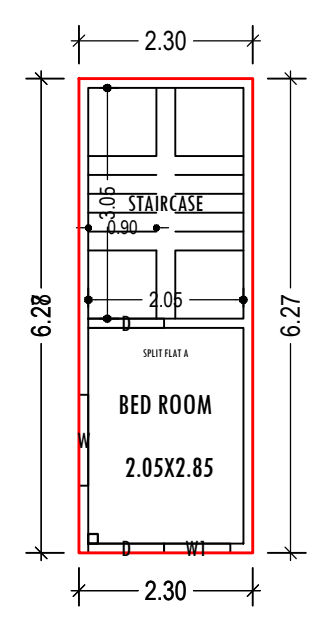

GROUND FLOOR PLAN (Proposed) (SCALE 1:100)

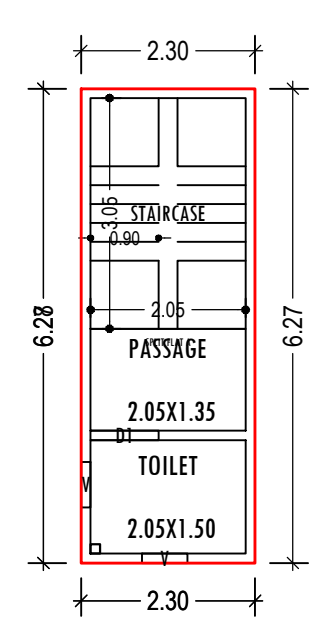

FIRST FLOOR PLAN (Proposed) (SCALE 1:100)

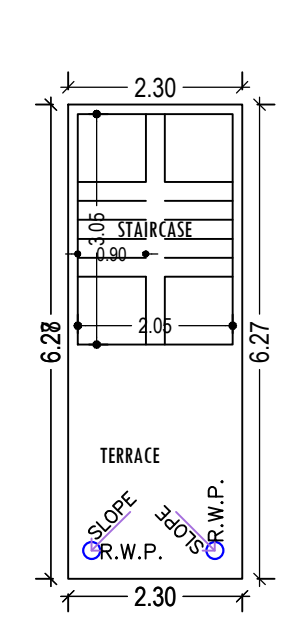

TERRACE FLOOR PLAN (SCALE 1:100)

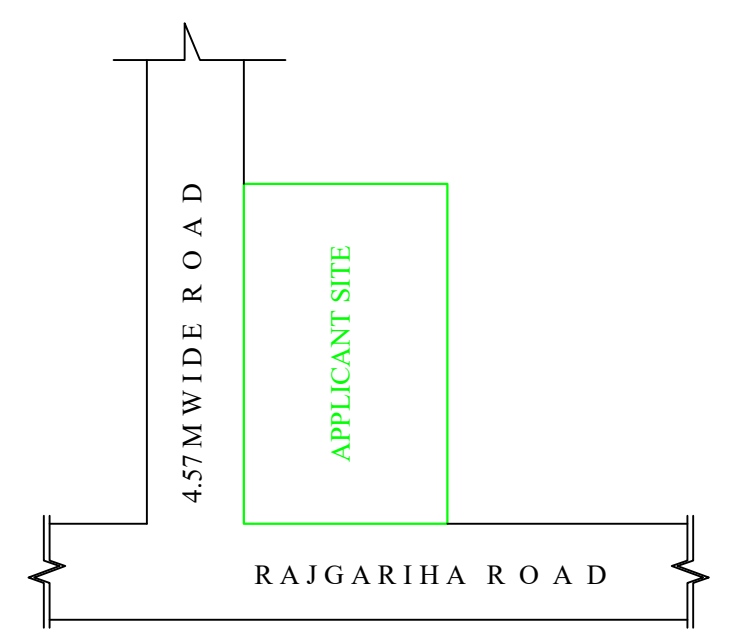

KEY PLAN NOT TO SCALE

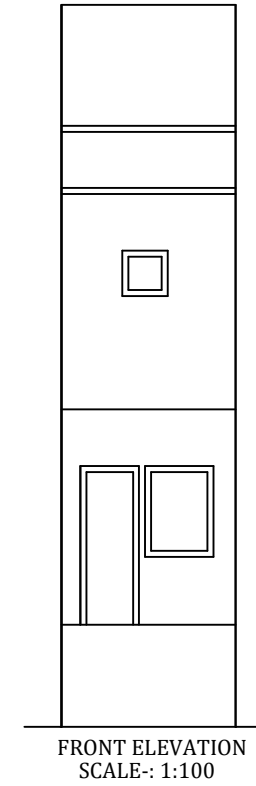

FRONT ELEVATION SCALE: 1:100

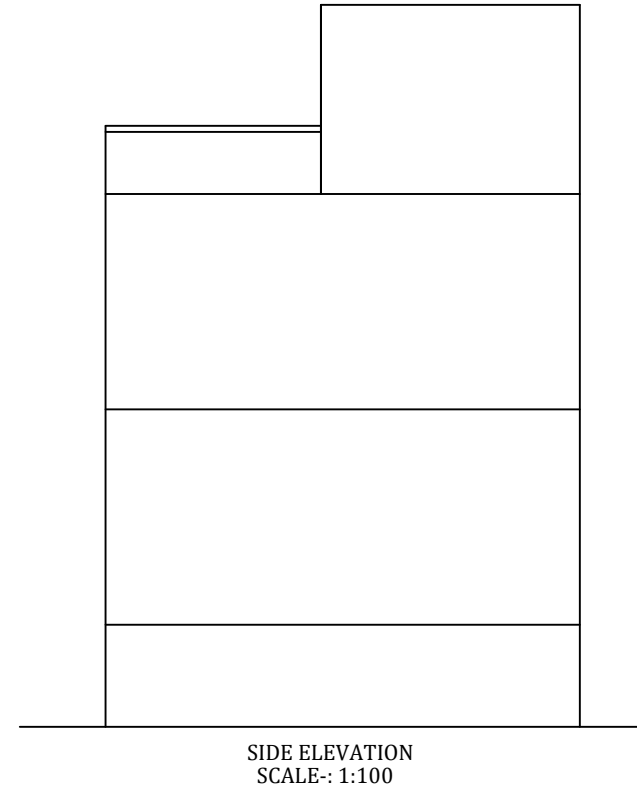

SIDE ELEVATION SCALE: 1:100

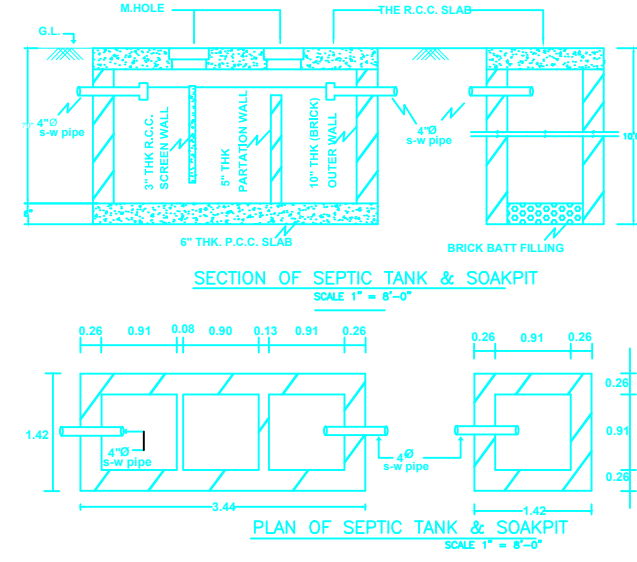

SECTION OF SEPTIC TANK & SOAKPIT SCALE: 1:100

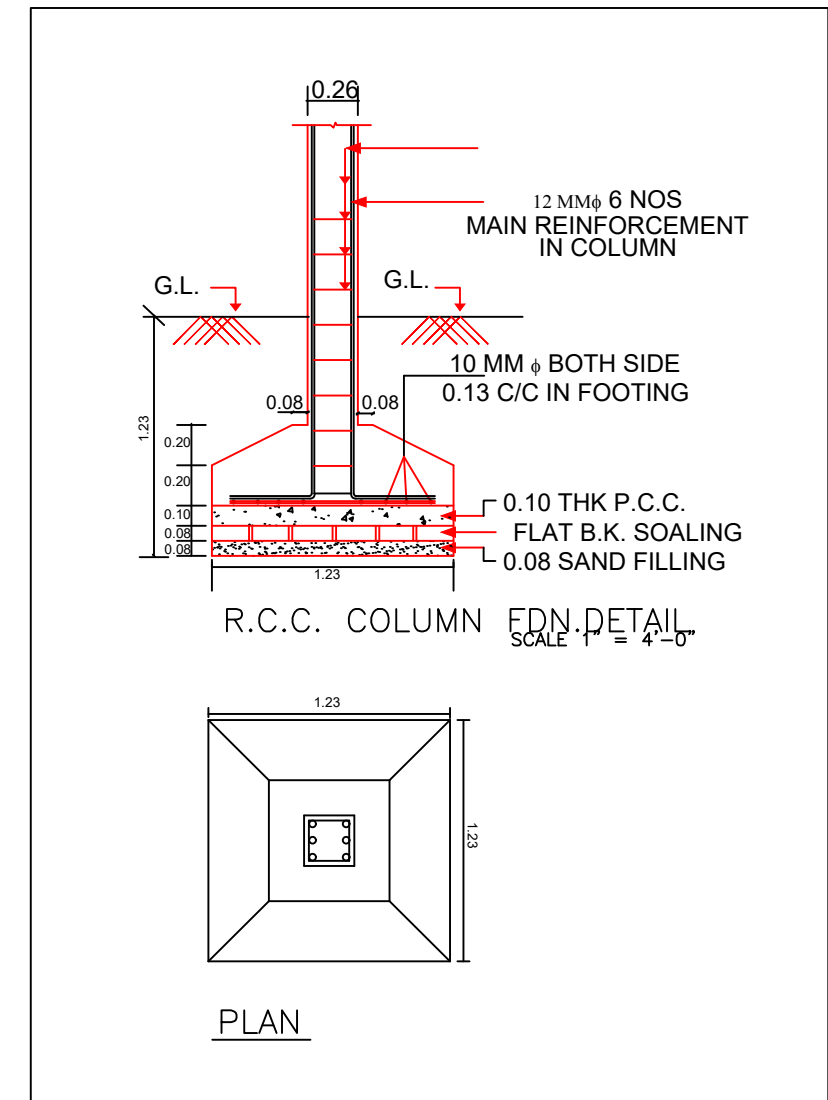

EDN DETAIL SCALE: 1:40

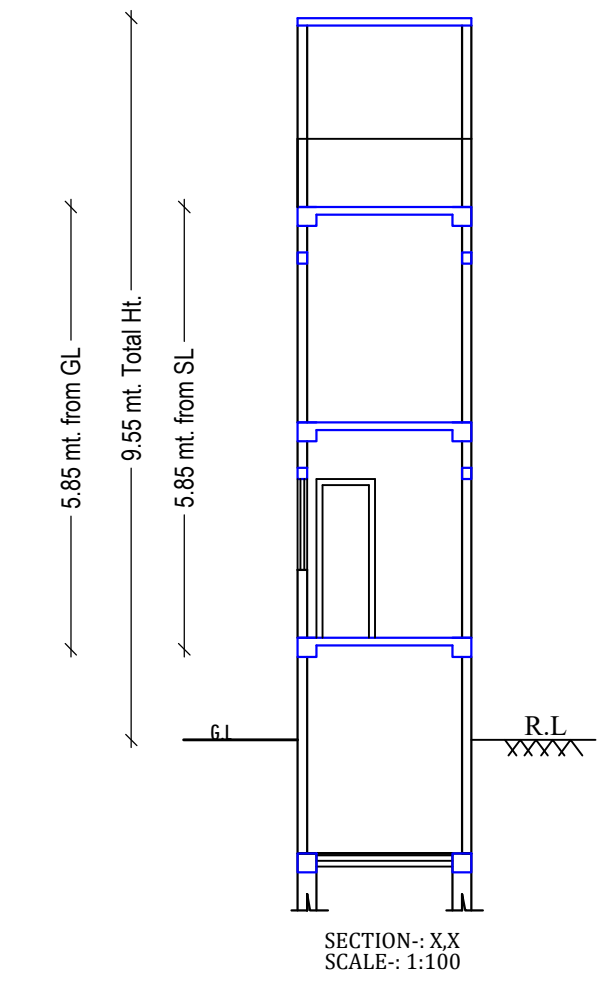

SECTION-XX SCALE: 1:100

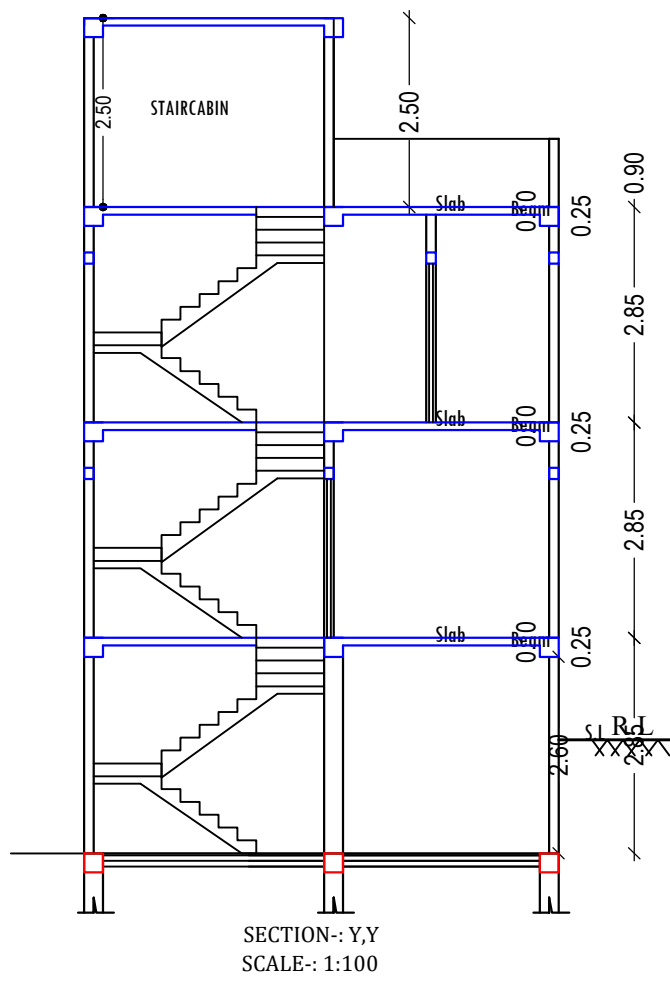

SECTION-YY SCALE: 1:100

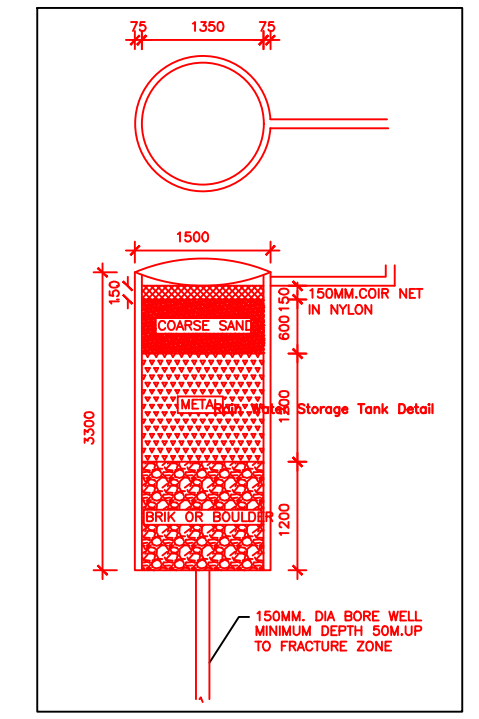

Storage Tank Detail

SCHEDULE OF DOOR:

BUILDING NAME	NAME	LENGTH	HEIGHT	NOS
AA (1 SRI SHAMBHU PRASAD BARNWAL 2 SMT KHUSHBU)	D1	0.90	2.10	01
AA (1 SRI SHAMBHU PRASAD BARNWAL 2 SMT KHUSHBU)	D	1.00	2.10	03

SCHEDULE OF WINDOW/VENTILATION:

BUILDING NAME	NAME	LENGTH	HEIGHT	NOS
AA (1 SRI SHAMBHU PRASAD BARNWAL 2 SMT KHUSHBU)	V	0.60	0.60	02
AA (1 SRI SHAMBHU PRASAD BARNWAL 2 SMT KHUSHBU)	W1	0.88	1.20	01
AA (1 SRI SHAMBHU PRASAD BARNWAL 2 SMT KHUSHBU)	W	1.20	1.20	01

Building : AA (1 SRI SHAMBHU PRASAD BARNWAL 2 SMT KHUSHBU)

Floor Name	Total Built Up Area (Sq.mt.)	Proposed FAR Area (Sq.mt.)	Total FAR Area (Sq.mt.)	Total Consumed Additional FAR Area (Sq.mt.)	Trmt (No.)
Basement Floor	14.43	14.43	14.43	14.43	01
Ground Floor	14.43	14.43	14.43	14.43	00
First Floor	14.43	14.43	14.43	14.43	00
Terrace Floor	0.00	0.00	0.00	0.00	00
Total :	43.29	43.29	43.29	43.29	01
Total Number of Same Buildings :	1				
Total :	43.29	43.29	43.29	43.29	01

Color	Description
Black	PLOT BOUNDARY
Green	ABUTTING ROAD
Red	PROPOSED CONSTRUCTION
Yellow	COMMON PLOT
Blue	ROAD WIDENING AREA
Light Blue	EXISTING (To be retained)
Dark Blue	EXISTING (To be demolished)

LTP NAME AND SIGNATURE	STRUCTURAL ENG'S NAME AND SIGNATURE	BUILDER NAME AND SIGNATURE	DIGITAL SIGNATURE
MD SHOAB ALAM JNP/ENG/001/2017			

AREA STATEMENT	VERSION NO. : 1.0.66	
JHUMRITILAIYA NAGAR PARISHAD	VERSION DATE: 16/10/2020	
PROJECT DETAIL:		
Region: JHARKHAND URBAN LOCAL BODIES	Plot Use: Residential	
District: KODERMA	Plot SubUse: Bungalow/ Dwelling / Non Apartment	
Authority: JHUMRITILAIYA NAGAR PARISHAD	PlotNearbyReligiousStructure: NA	
Inward No: JNP/IBP/0067/W10/2023	PlotSubPlot No: 7457	
Application Type: General Proposal	North: Road Width - LAND OF SMT MANJU DEVI JAIN	
Project Type: Building Permission	South: Road Width - 6.10M WIDE RAJGARHIA ROAD	
Nature of Development: New	East: Plot No. - LAND OF PADAM KUMAR JAIN	
Location of Development Area: Old Area	West: Road Width - 4.57M WIDE ROAD	
AREA DETAILS:		
AREA OF PLOT (Minimum)	(A)	29.25
NET AREA OF PLOT(Gross Plot Area - Deduction from Gross Plot area)	(A-Deductions)	29.25
Deduction for Balance Plot Area(from Gross Plot Area)		
Common Plot		2.92
Total		2.92
BALANCE AREA OF PLOT(Net Plot Area - Recreational/Amenity space)	(A-Deductions)	26.33
PLOT AREA FOR COVERAGE(Net Plot Area)	(A-Deductions)	29.25
Plot Area for FAR (Net Plot Area + RoadWidening Area)	(A-Deductions)	29.25
COVERAGE CHECK		
Permissible Coverage area ( 70.00 % )		20.48
Proposed Coverage Area ( 49.34 % )		14.43
Total Prop. Coverage Area ( 49.34 % )		14.43
Balance coverage area ( 20.69 % )		6.05
FAR CHECK		
Perm. FAR Area ( 2.000 )		58.50
Total Perm. FAR area		58.50
Residential FAR		43.30
Proposed FAR Area		43.30
Total Proposed FAR Area		43.30
Consumed FAR (Factor)		1.48
Balance FAR Area		15.20
BUILT UP AREA CHECK		
Total Proposed BuiltUp Area		43.29
ARCHITECT (Regd)		MD SHOAB ALAM
ENGINEER (Regd)		
SUPERVISOR (Regd)		
OWNER (Regd)		1 SRI SHAMBHU PRASAD BARNWAL 2 SMT KHUSHBU
DEVELOPMENT AUTHORITY		LOCAL BODY

Floor Name	Building Name		Total	
	Proposed Built Up Area (Sq.mt.)	Proposed FAR Area (Sq.mt.)	Total Proposed Built Up Area (Sq.mt.)	Total FAR Area (Sq.mt.)
Basement Floor	14.43	14.43	14.43	14.43
Ground Floor	14.43	14.43	14.43	14.43
First Floor	14.43	14.43	14.43	14.43
Terrace Floor	0.00	0.00	0.00	0.00
Total :	43.29	43.29	43.29	43.29

Building Name	Building Use	Building SubUse	Building Structure
AA (1 SRI SHAMBHU PRASAD BARNWAL 2 SMT KHUSHBU)	Residential	Bungalow/ Dwelling / Non Apartment	Non-Highrise

Building	No. of Same Bldg	Total Built Up Area (Sq.mt.)	Proposed FAR Area (Sq.mt.)	Total FAR Area (Sq.mt.)	Total Consumed Additional FAR Area (Sq.mt.)	Trmt (No.)
AA (1 SRI SHAMBHU PRASAD BARNWAL 2 SMT KHUSHBU)	1	43.29	43.29	43.29	43.29	01
Grand Total :	1	43.29	43.29	43.29	43.29	01

FLOOR	Name	UnitBUA Type	UnitBUA Area	Carpet Area	No. of Rooms	No. of Tenement
BASEMENT FLOOR PLAN	SPLIT FLAT A	FLAT	18.30	18.25	1	1
GROUND FLOOR PLAN	SPLIT FLAT A	FLAT	0.00	0.00	1	0
FIRST FLOOR PLAN	SPLIT FLAT A	FLAT	0.00	0.00	2	0
Total:	-	-	18.30	18.25	4	1