

SITE PLAN
SCALE :- 1=100

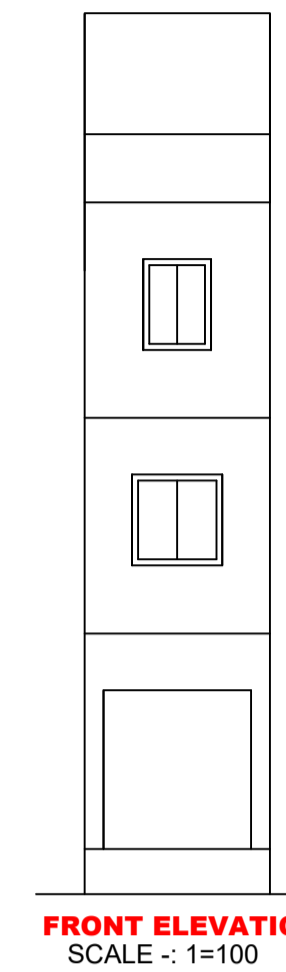

FRONT ELEVATION
SCALE :- 1=100

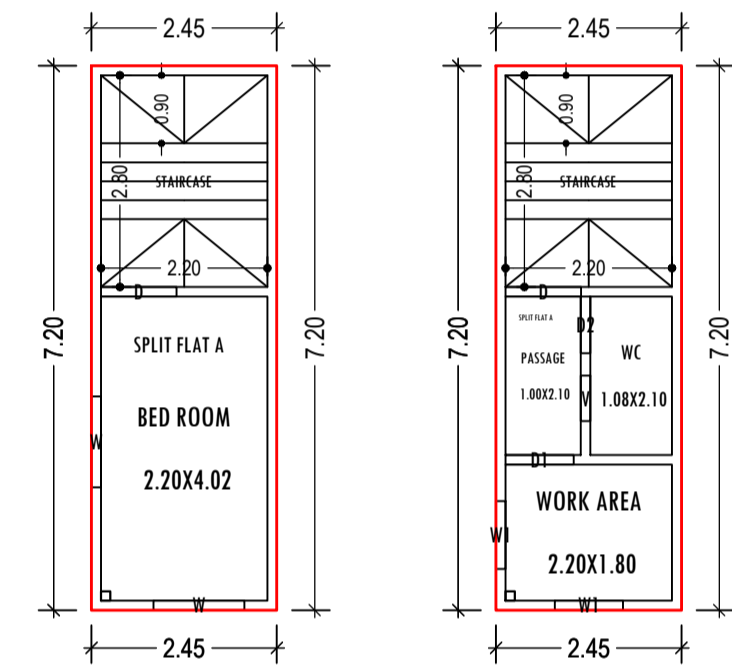

GROUND FLOOR PLAN
(Proposed)
SCALE 1:100

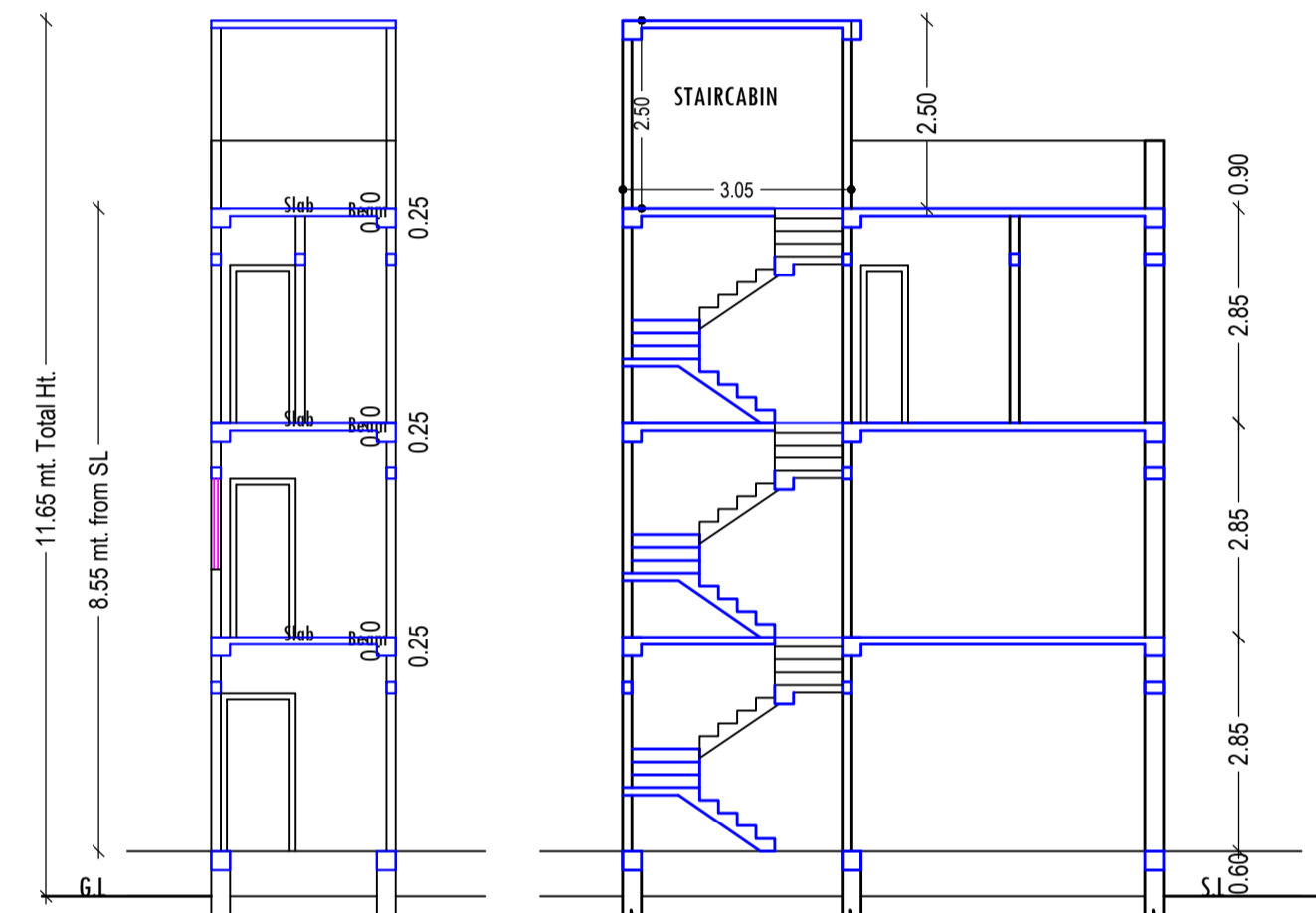

SECOND FLOOR PLAN
(Proposed)
SCALE 1:100

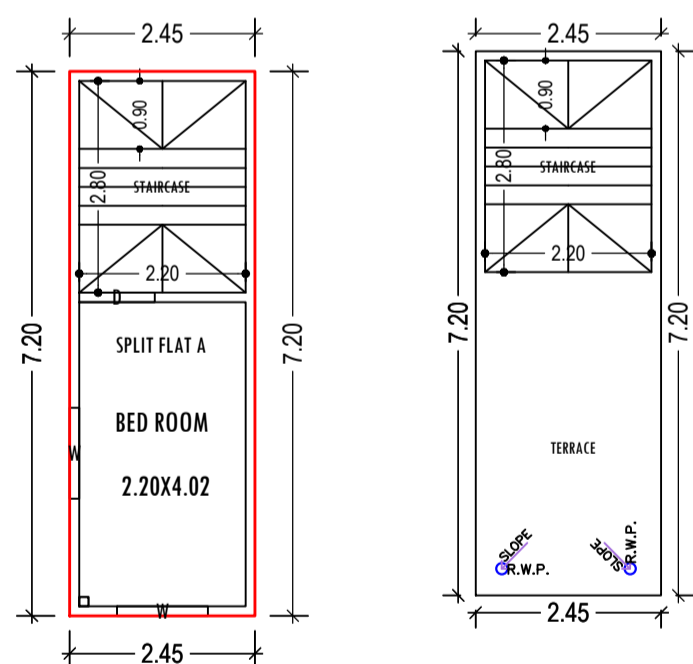

FIRST FLOOR PLAN
(Proposed)
SCALE 1:100

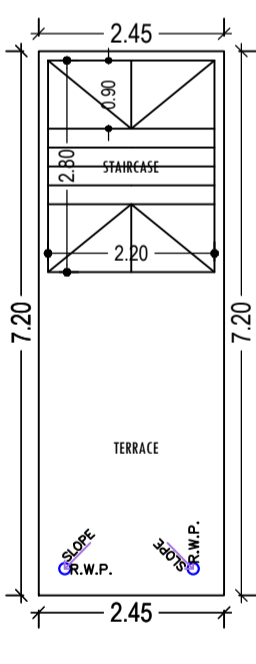

TERRACE FLOOR PLAN
(Proposed)
SCALE 1:100

Building -AA (1 RAMCHANDRA SAW 2 ARATI DEVI 3 MUNIYA DEVI 4 PUNAM DEVI)

| Floor Name | Total Built Up Area (Sq.mt.) | Proposed FAR Area (Sq.mt.) | Total FAR Area (Sq.mt.) | Total Consumed Additional FAR Area (Sq.mt.) | Tnmt (No.) |
|--------------------------------|------------------------------|----------------------------|-------------------------|---|------------|
| Ground Floor | 17.65 | 17.65 | 17.65 | 17.65 | 01 |
| First Floor | 17.65 | 17.65 | 17.65 | 17.65 | 00 |
| Second Floor | 17.65 | 17.65 | 17.65 | 17.65 | 00 |
| Terrace Floor | 0.00 | 0.00 | 0.00 | 0.00 | 00 |
| Total : | 52.95 | 52.95 | 52.95 | 52.95 | 01 |
| Total Number of Same Buildings | 1 | | | | |
| Total : | 52.95 | 52.95 | 52.95 | 52.95 | 01 |

SCHEDULE OF DOOR:

| BUILDING NAME | NAME | LENGTH | HEIGHT | NOS |
|---|------|--------|--------|-----|
| AA (1 RAMCHANDRA SAW 2 ARATI DEVI 3 MUNIYA DEVI 4 PUNAM DEVI) | D2 | 0.75 | 2.10 | 01 |
| AA (1 RAMCHANDRA SAW 2 ARATI DEVI 3 MUNIYA DEVI 4 PUNAM DEVI) | D1 | 0.90 | 2.10 | 01 |
| AA (1 RAMCHANDRA SAW 2 ARATI DEVI 3 MUNIYA DEVI 4 PUNAM DEVI) | D | 1.00 | 2.10 | 03 |

SCHEDULE OF WINDOW/VENTILATION:

| BUILDING NAME | NAME | LENGTH | HEIGHT | NOS |
|---|------|--------|--------|-----|
| AA (1 RAMCHANDRA SAW 2 ARATI DEVI 3 MUNIYA DEVI 4 PUNAM DEVI) | V | 0.60 | 0.60 | 01 |
| AA (1 RAMCHANDRA SAW 2 ARATI DEVI 3 MUNIYA DEVI 4 PUNAM DEVI) | W1 | 0.90 | 1.20 | 02 |
| AA (1 RAMCHANDRA SAW 2 ARATI DEVI 3 MUNIYA DEVI 4 PUNAM DEVI) | W | 1.20 | 1.20 | 04 |

UnitBUA Table for Building -AA (1 RAMCHANDRA SAW 2 ARATI DEVI 3 MUNIYA DEVI 4 PUNAM DEVI)

| FLOOR | Name | UnitBUA Type | UnitBUA Area | Carpet Area | No. of Rooms | No. of Tenement |
|-------------------|--------------|--------------|--------------|-------------|--------------|-----------------|
| GROUND FLOOR PLAN | SPLIT FLAT A | FLAT | 26.57 | 26.53 | 1 | 1 |
| FIRST FLOOR PLAN | SPLIT FLAT A | FLAT | 0.00 | 0.00 | 1 | 0 |
| SECOND FLOOR PLAN | SPLIT FLAT A | FLAT | 0.00 | 0.00 | 3 | 0 |
| Total: | - | - | 26.57 | 26.53 | 5 | 1 |

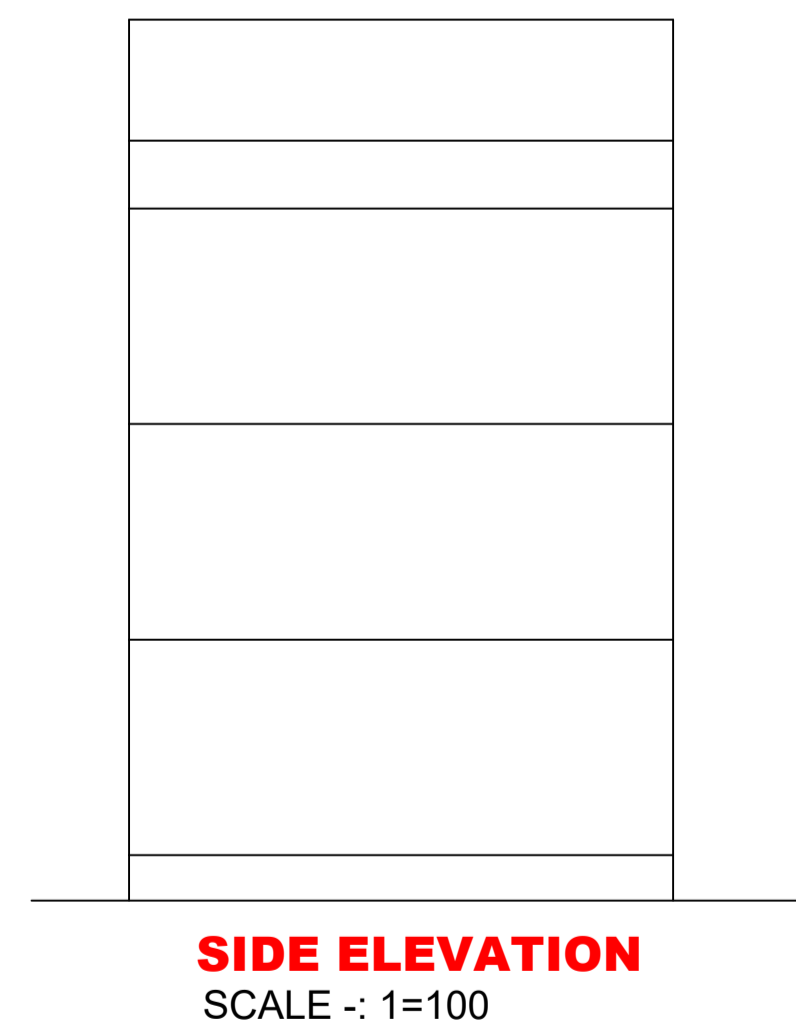

SIDE ELEVATION
SCALE :- 1=100

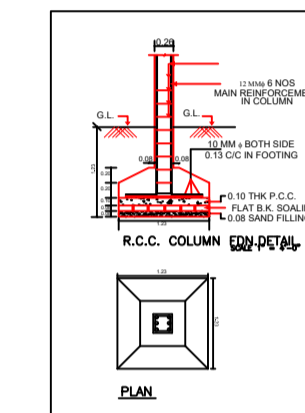
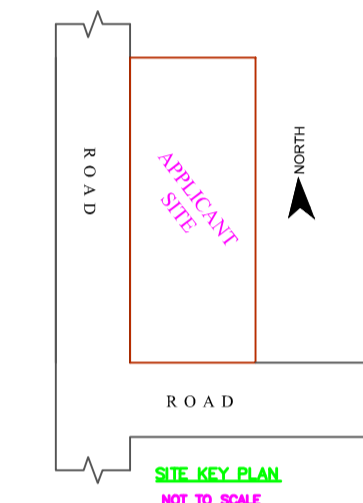

| AREA STATEMENT | | VERSION NO. : 1.0.66 |
|--|--|--------------------------|
| JHUMRITILAIYA NAGAR PARISHAD | | VERSION DATE: 16/10/2020 |
| PROJECT DETAIL: | | |
| Region : JHARKHAND URBAN LOCAL BODIES | Plot Use: Residential | |
| District: KODERMA | Plot SubUse: Bungalow/ Dwelling / Non Apartment | |
| Authority: JHUMRITILAIYA NAGAR PARISHAD | PlotNearby/ReligiousStructure: NA | |
| Inward No: JNP/BB/0073/W10/2023 | Plot/SubPlot No: 7457 | |
| Application Type: General Proposal | North: Plot No. - LAND OF PAWAN KUMAR YADAV | |
| Project Type: Building Permission | South: Road Width - 6.10M WIDE RAJAGARIH ROAD | |
| Nature of Development: New | East: Plot No. - OWN LAND OF VENDER | |
| Location of Development Area: Old Area | West: Road Width - 4.57M WIDE ROAD | |
| AREA DETAILS: | | |
| AREA OF PLOT (Minimum) | (A) | SQ.MT. 32.17 |
| NET AREA OF PLOT(Gross Plot Area - Deduction from Gross Plot area) | (A-Deductions) | 32.17 |
| Deduction for Balance Plot Area(from Gross Plot Area) | | |
| Common Plot | | 3.31 |
| Total | | 3.31 |
| BALANCE AREA OF PLOT(Net Plot Area - Recreational/Amenity space) | (A-Deductions) | 28.86 |
| PLOT AREA FOR COVERAGE(Net Plot Area) | (A-Deductions) | 32.17 |
| Plot Area for FAR (Net Plot Area + RoadWidening Area) | (A-Deductions) | 32.17 |
| COVERAGE CHECK | | |
| Permissible Coverage area (70.00 %) | | 22.52 |
| Proposed Coverage Area (54.86 %) | | 17.65 |
| Total Prop. Coverage Area (54.86 %) | | 17.65 |
| Balance coverage area (15.14 %) | | 4.87 |
| FAR CHECK | | |
| Perm. FAR Area (2.000) | | 64.34 |
| Total Perm. FAR area | | 64.34 |
| Residential FAR | | 52.94 |
| Proposed FAR Area | | 52.94 |
| Total Proposed FAR Area | | 52.94 |
| Consumed FAR (Factor) | | 1.65 |
| Balance FAR Area | | 11.40 |
| BUILT UP AREA CHECK | | |
| Total Proposed BuiltUp Area | | 52.95 |
| ARCHITECT (Regd) MD SHOAB ALAM | | |
| ENGINEER (Regd) | | |
| SUPERVISOR (Regd) | | |
| OWNER (Regd) | 1 SRI RAMCHANDRA SAW 2 SMT ARATI DEVI 3 SMT MUNIYA DEVI 4 SMT PUNAM DEVI | |
| DEVELOPMENT AUTHORITY | | LOCAL BODY |

| COLOR INDEX | |
|-----------------------------|--------|
| PLOT BOUNDARY | Black |
| ABUTTING ROAD | Green |
| PROPOSED CONSTRUCTION | Red |
| COMMON PLOT | Yellow |
| ROAD WIDENING AREA | Blue |
| EXISTING (To be retained) | Orange |
| EXISTING (To be demolished) | White |

Buildingwise Floor FAR Details

| Floor Name | Building Name | | Total | | |
|----------------|---|---------------------------------|----------------------------|---------------------------------------|-------------------------|
| | AA (1 RAMCHANDRA SAW 2 ARATI DEVI 3 MUNIYA DEVI 4 PUNAM DEVI) | Proposed Built Up Area (Sq.mt.) | Proposed FAR Area (Sq.mt.) | Total Proposed Built Up Area (Sq.mt.) | Total FAR Area (Sq.mt.) |
| Ground Floor | 17.65 | 17.65 | 17.65 | 17.65 | 17.65 |
| First Floor | 17.65 | 17.65 | 17.65 | 17.65 | 17.65 |
| Second Floor | 17.65 | 17.65 | 17.65 | 17.65 | 17.65 |
| Terrace Floor | 0.00 | 0.00 | 0.00 | 0.00 | 0.00 |
| Total : | 52.95 | 52.95 | 52.95 | 52.95 | 52.95 |

Building USE/SUBUSE Details

| Building Name | Building Use | Building SubUse | Building Structure |
|---|--------------|------------------------------------|--------------------|
| AA (1 RAMCHANDRA SAW 2 ARATI DEVI 3 MUNIYA DEVI 4 PUNAM DEVI) | Residential | Bungalow/ Dwelling / Non Apartment | Non-Highrise |

FAR & Tenement Details (Table 4c-1)

| Building | No. of Same Bldg | Total Built Up Area (Sq.mt.) | Proposed FAR Area (Sq.mt.) | Total FAR Area (Sq.mt.) | Total Consumed Additional FAR Area (Sq.mt.) | Tnmt (No.) |
|---|------------------|------------------------------|----------------------------|-------------------------|---|------------|
| AA (1 RAMCHANDRA SAW 2 ARATI DEVI 3 MUNIYA DEVI 4 PUNAM DEVI) | 1 | 52.95 | 52.95 | 52.95 | 52.95 | 01 |
| Grand Total : | 1 | 52.95 | 52.95 | 52.95 | 52.95 | 01 |

