

SITE PLAN
SCALE: 1:100

FAR & Tenement Details (Table 4c-1)

Building	No. of Same Bldg	Total Built Up Area (Sq.mt.)	Proposed FAR Area (Sq.mt.) Resi.	Total FAR Area (Sq.mt.)	Total Consumed Additional FAR Area (Sq.mt.)	Tmmt (No.)
AA (SRI ASHOK KUMAR BARNWAL)	1	36.64	36.64	36.64	36.64	01
Grand Total :	1	36.64	36.64	36.64	36.64	01

Proposal Basic Information

Proposal File No.	JNP/IBP/0035/W10/2023
Owner Name	SRI ASHOK KUMAR BARNWAL
Khata No	631
Plot No	7457
Village Name	Tilaiya
Use	Residential
SubUse	Bungalow/ Dwelling / Non Apartment

AREA STATEMENT	VERSION NO.: 1.0.66
JHUMRITILAIYA NAGAR PARISHAD	VERSION DATE: 16/10/2020
PROJECT DETAIL:	
Region: JHARKHAND URBAN LOCAL BODIES	Plot Use: Residential
District: KODERMA	Plot SubUse: Bungalow/ Dwelling / Non Apartment
Authority: JHUMRITILAIYA NAGAR PARISHAD	PlotNearby/ReligiousStructure: NA
Inward No: JNP/IBP/0035/W10/2023	Plot/SubPlot No: 7457
Application Type: General Proposal	North Plot No - LAND OF BINAY KUMAR MODI
Project Type: Building Permission	South Plot No - OWN LAND OF VENDER VISHNU GOPAL RAJGARHIA
Nature of Development: New	East: Road Width - 4.57M WIDE ROAD
Location of Development Area: Old Area	West: Plot No. - LAND OF SMT MANJU DEVI JAIN & OWN LAND OF VENDER
AREA DETAILS:	
AREA OF PLOT (Minimum)	(A) 35.07
NET AREA OF PLOT(Gross Plot Area - Deduction from Gross Plot area)	(A-Deductions) 35.07
Deduction for Balance Plot Area(from Gross Plot Area)	
Common Plot	3.20
BALANCE AREA OF PLOT(Net Plot Area - Recreational/Amenity space)	(A-Deductions) 31.87
PLOT AREA FOR COVERAGE(Net Plot Area)	(A-Deductions) 35.07
Plot Area for FAR (Net Plot Area + RoadWidening Area)	(A-Deductions) 35.07
COVERAGE CHECK	
Permissible Coverage area (70.00 %)	24.55
Proposed Coverage Area (52.24 %)	18.32
Total Prop. Coverage Area (52.24 %)	18.32
Balance coverage area (17.76 %)	6.23
FAR CHECK	
Perm. FAR Area (1.500)	52.60
Total Perm. FAR area	52.60
Residential FAR	36.64
Proposed FAR Area	36.64
Total Proposed FAR Area	36.64
Consumed FAR (Factor)	1.04
Balance FAR Area	15.96
BUILT UP AREA CHECK	
Total Proposed BuiltUp Area	36.64
ARCHITECT (Regd)	MD SHOAB ALAM
ENGINEER (Regd)	
SUPERVISOR (Regd)	
OWNER (Regd)	SRI ASHOK KUMAR BARNWAL
DEVELOPMENT AUTHORITY	LOCAL BODY

COLOR INDEX	
PLOT BOUNDARY	Black
ABUTTING ROAD	Green
PROPOSED CONSTRUCTION	Red
COMMON PLOT	Yellow
ROAD WIDENING AREA	Orange
EXISTING (To be retained)	Blue
EXISTING (To be demolished)	Light Blue

Buildingwise Floor FAR Details

Floor Name	Building Name		Total	
	Proposed Built Up Area (Sq.mt.)	Proposed FAR Area (Sq.mt.)	Total Proposed Built Up Area (Sq.mt.)	Total FAR Area (Sq.mt.)
Ground Floor	18.32	18.32	18.32	18.32
First Floor	18.32	18.32	18.32	18.32
Terrace Floor	0.00	0.00	0.00	0.00
Total :	36.64	36.64	36.64	36.64

Building USE/SUBUSE Details

Building Name	Building Use	Building SubUse	Building Structure
AA (SRI ASHOK KUMAR BARNWAL)	Residential	Bungalow/ Dwelling / Non Apartment	Non-Highrise

LTP NAME AND SIGNATURE	STRUCTURAL ENG'S NAME AND SIGNATURE	BUILDER NAME AND SIGNATURE	DIGITAL SIGNATURE
MD SHOAB ALAM JNP/ENG/0001/2017			

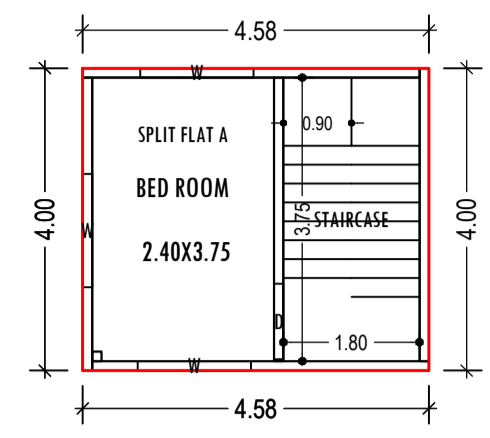

GROUND FLOOR PLAN
(Proposed)
(SCALE 1:100)

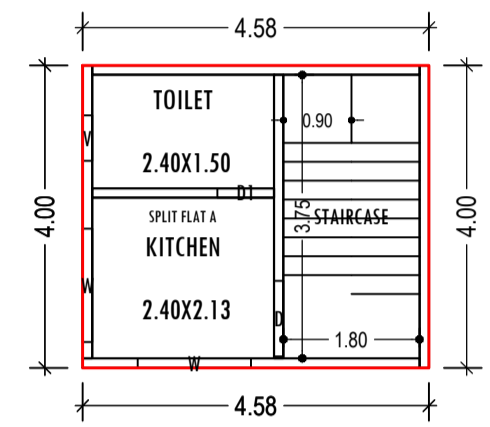

FIRST FLOOR PLAN
(Proposed)
(SCALE 1:100)

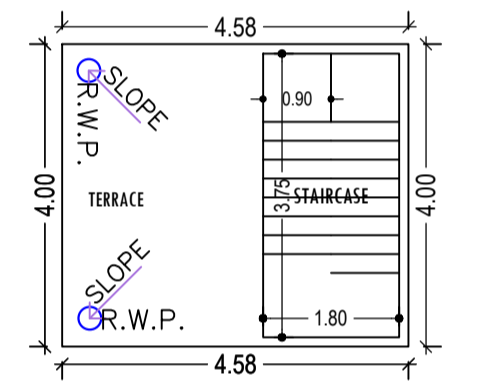

TERRACE FLOOR PLAN
(SCALE 1:100)

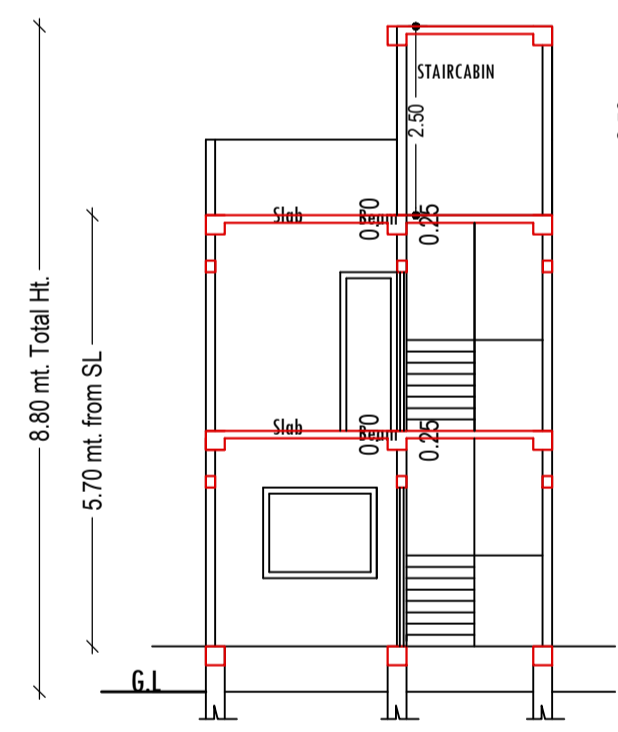

SECTION--YY
SCALE: 1:100

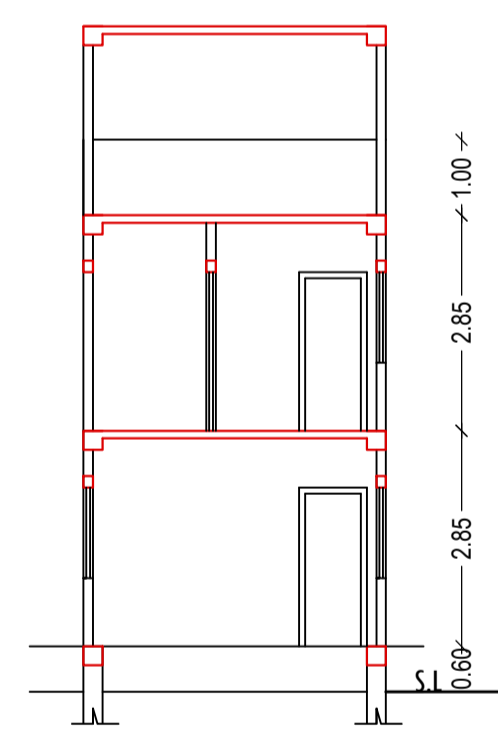

SECTION--YY
SCALE: 1:100

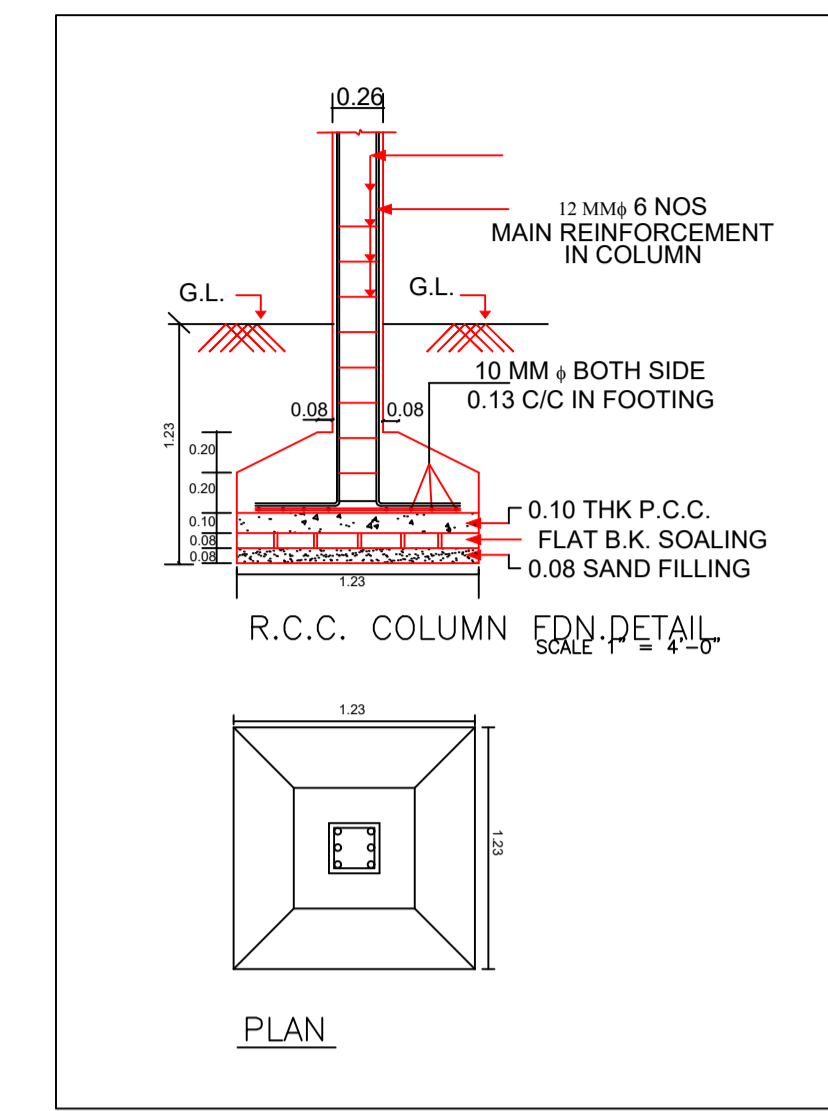

R.C.C. COLUMN EDN. DETAIL
SCALE 1" data-bbox="750 300 770 315"/>

Proposal Basic Information

Proposal File No.	JNP/EP/0035/W10/2023
Owner Name	SRI ASHOK KUMAR BARNWAL
Khata No	631
Plot No	7457
Village Name	Tilaiya
Use	Residential
SubUse	Bungalow/ Dwelling / Non Apartment

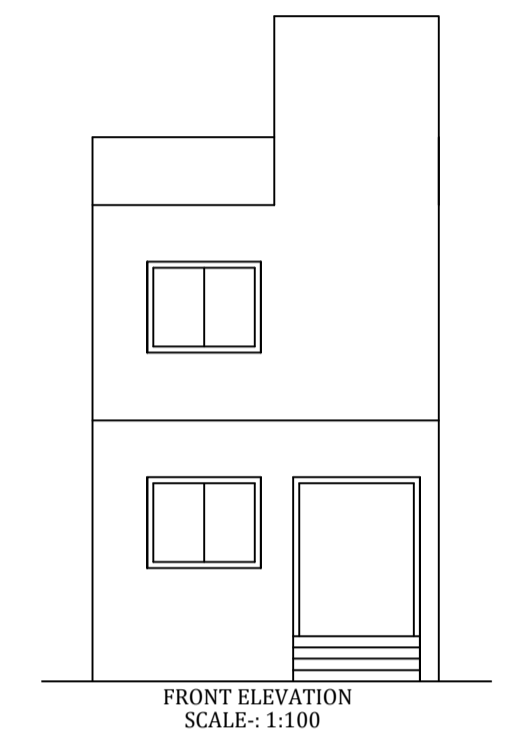

FRONT ELEVATION
SCALE: 1:100

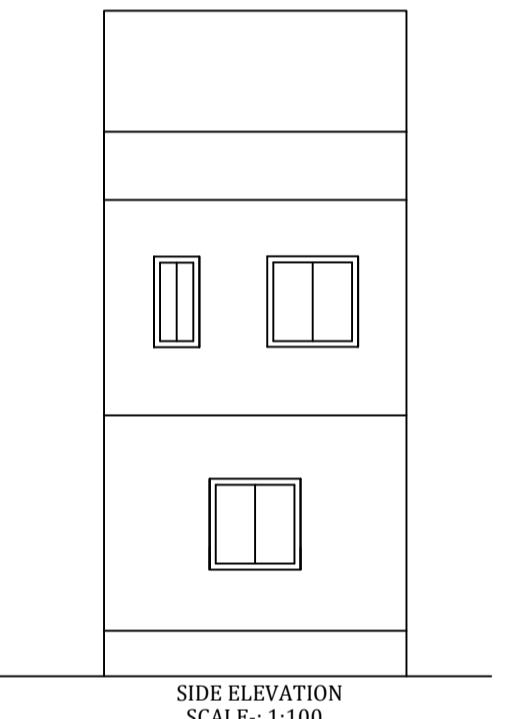
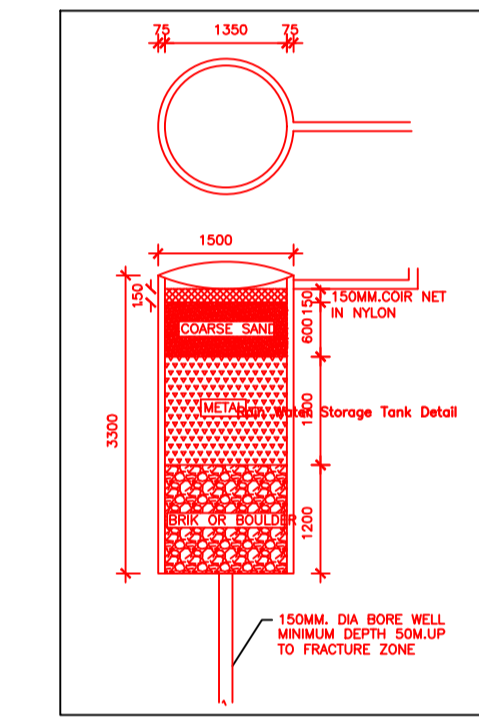

SIDE ELEVATION
SCALE: 1:100

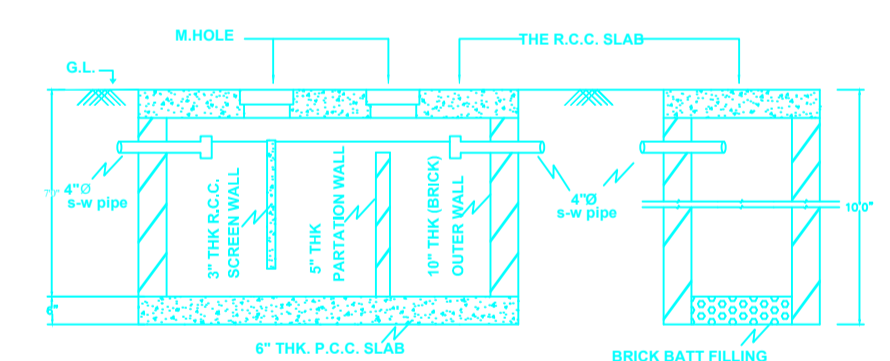

SECTION OF SEPTIC TANK & SOAKPIT
SCALE 1" data-bbox="870 655 955 670"/>

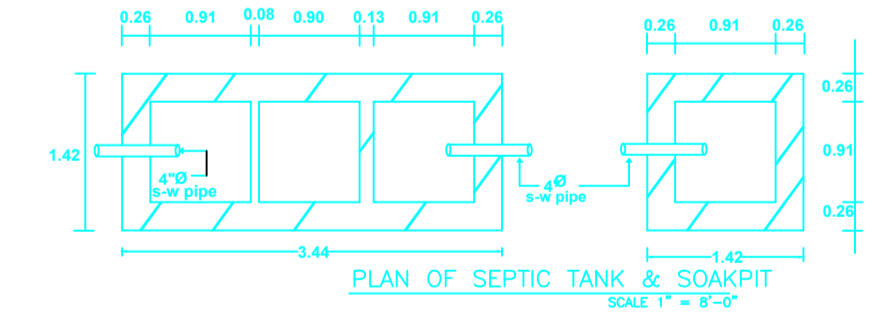

PLAN OF SEPTIC TANK & SOAKPIT
SCALE 1" data-bbox="885 735 955 750"/>

Building -AA (SRI ASHOK KUMAR BARNWAL)

Floor Name	Total Built Up Area (Sq.mt.)	Proposed FAR Area (Sq.mt.) Resi.	Total FAR Area (Sq.mt.)	Total Consumed Additional FAR Area (Sq.mt.)	Tnmt (No.)
Ground Floor	18.32	18.32	18.32	18.32	01
First Floor	18.32	18.32	18.32	18.32	00
Terrace Floor	0.00	0.00	0.00	0.00	00
Total:	36.64	36.64	36.64	36.64	01
Total Number of Same Buildings	1				
Total:	36.64	36.64	36.64	36.64	01

SCHEDULE OF DOOR:

BUILDING NAME	NAME	LENGTH	HEIGHT	NOS
AA (SRI ASHOK KUMAR BARNWAL)	D1	0.75	2.10	01
AA (SRI ASHOK KUMAR BARNWAL)	D	1.00	2.10	02

SCHEDULE OF WINDOW/VENTILATION:

BUILDING NAME	NAME	LENGTH	HEIGHT	NOS
AA (SRI ASHOK KUMAR BARNWAL)	V	0.60	0.60	01
AA (SRI ASHOK KUMAR BARNWAL)	W	1.50	1.20	05

UnitBUA Table for Building -AA (SRI ASHOK KUMAR BARNWAL)

FLOOR	Name	UnitBUA Type	UnitBUA Area	Carpet Area	No. of Rooms	No. of Tenement
GROUND FLOOR PLAN	SPLIT FLAT A	FLAT	18.04	17.72	1	1
FIRST FLOOR PLAN	SPLIT FLAT A	FLAT	0.00	0.00	2	0
Total:	-	-	18.04	17.72	3	1

LTP NAME AND SIGNATURE	STRUCTURAL ENG'S NAME AND SIGNATURE	BUILDER NAME AND SIGNATURE	DIGITAL SIGNATURE
MD SHOAIB ALAM JNP/ENG/0001/2017			

Proposal Basic Information	
Proposal File No.	JNP/EP/0035/W10/2023
Owner Name	SRI ASHOK KUMAR BARNWAL
Khata No	631
Plot No	7457
Village Name	Tilaiya
Use	Residential
SubUse	Bungalow/ Dwelling / Non Apartment

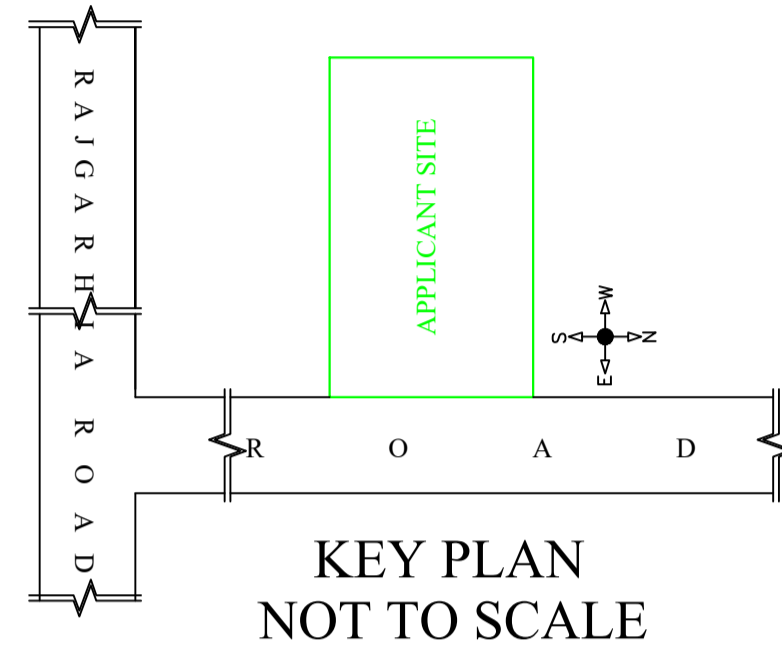

LTP NAME AND SIGNATURE	STRUCTURAL ENG'S NAME AND SIGNATURE	BUILDER NAME AND SIGNATURE	DIGITAL SIGNATURE
MD. SHOAIB ALAM JNP/ENG/0001/2017			