

Proposal Basic Information

Proposal File No.	JNP/BI/0034/W10/2023
Owner Name	SRI BINAY KUMAR MODI
Khata No	631
Plot No	7457
Village Name	Tilaiya
Use	Residential
SubUse	Bungalow/ Dwelling / Non Apartment

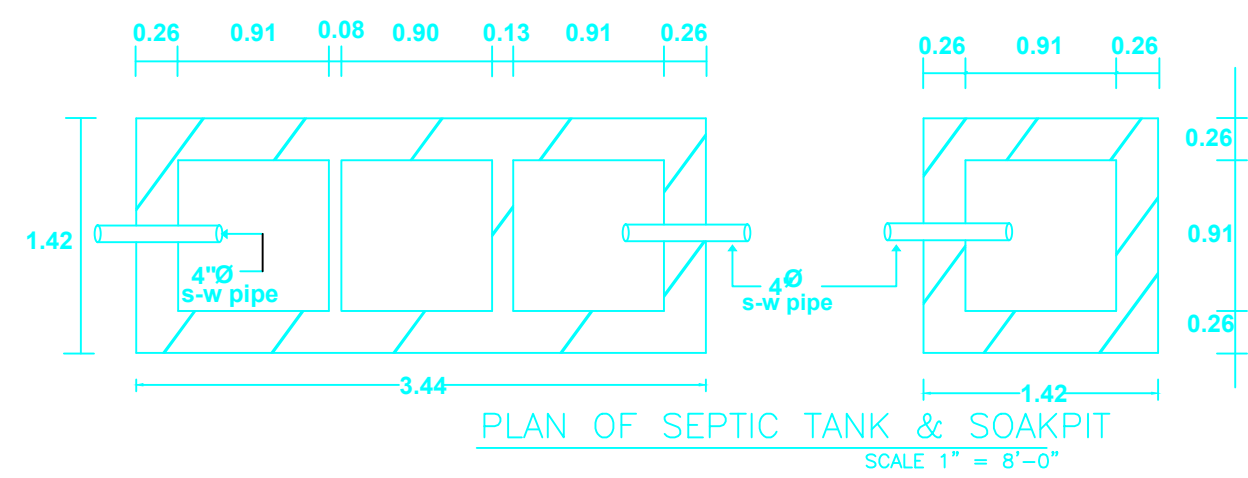
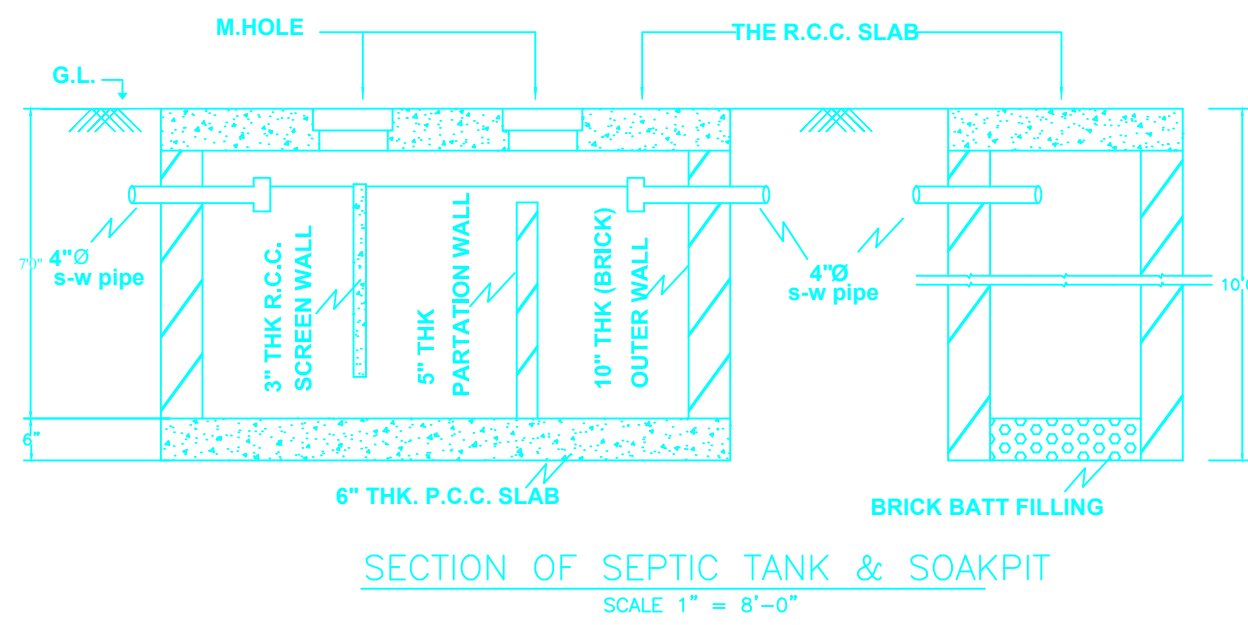
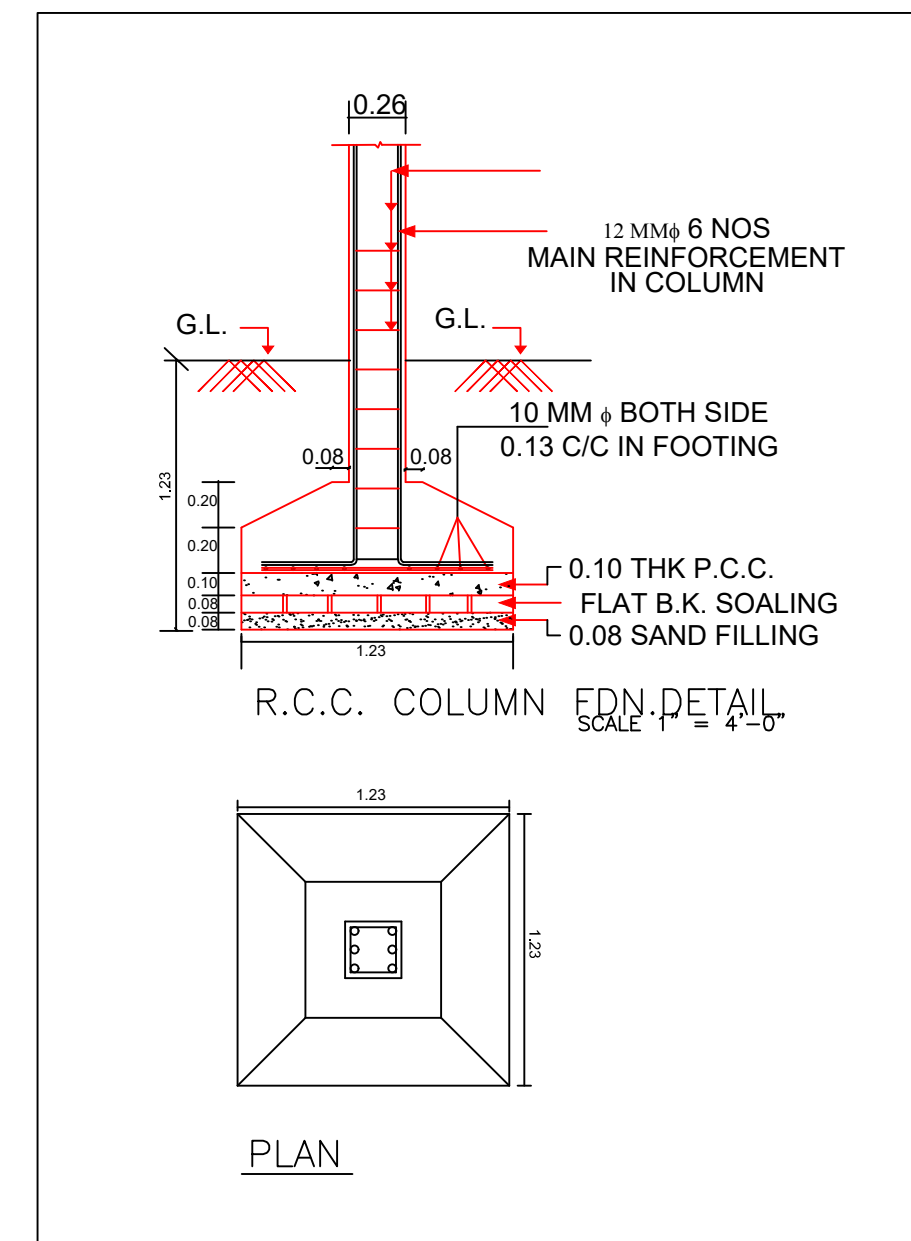
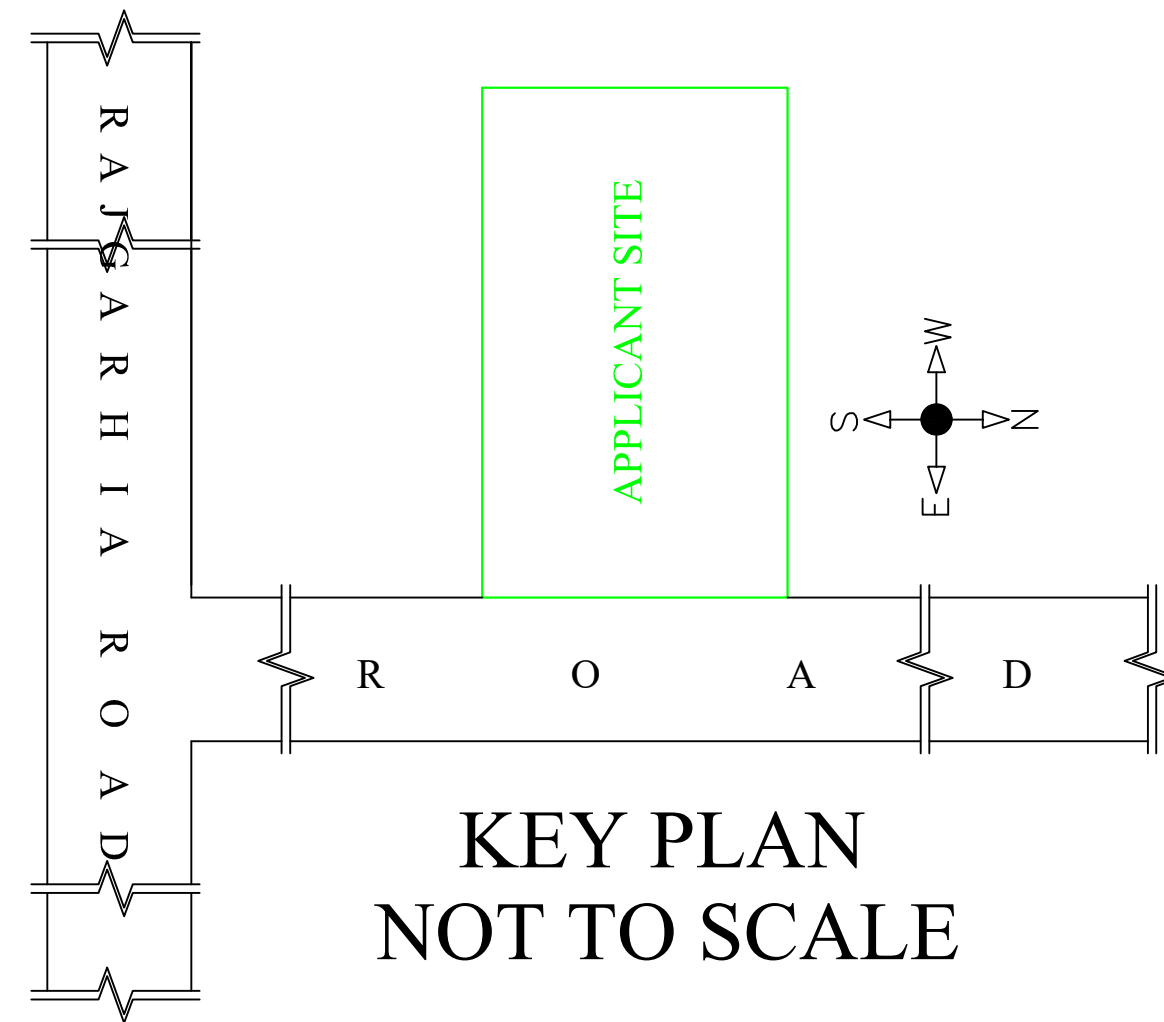
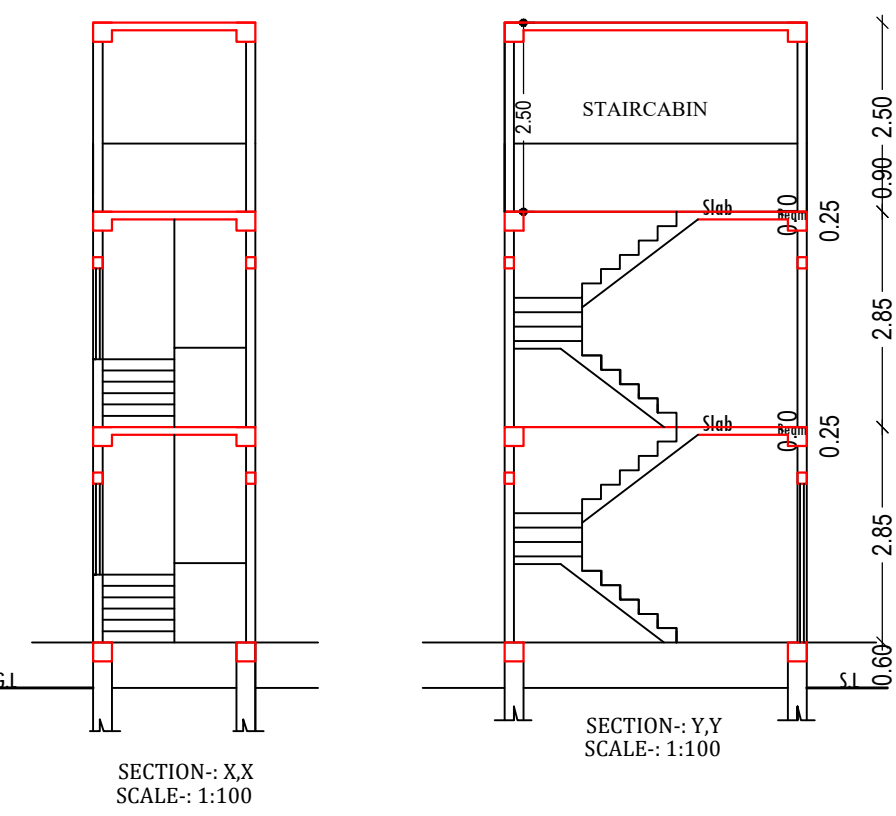
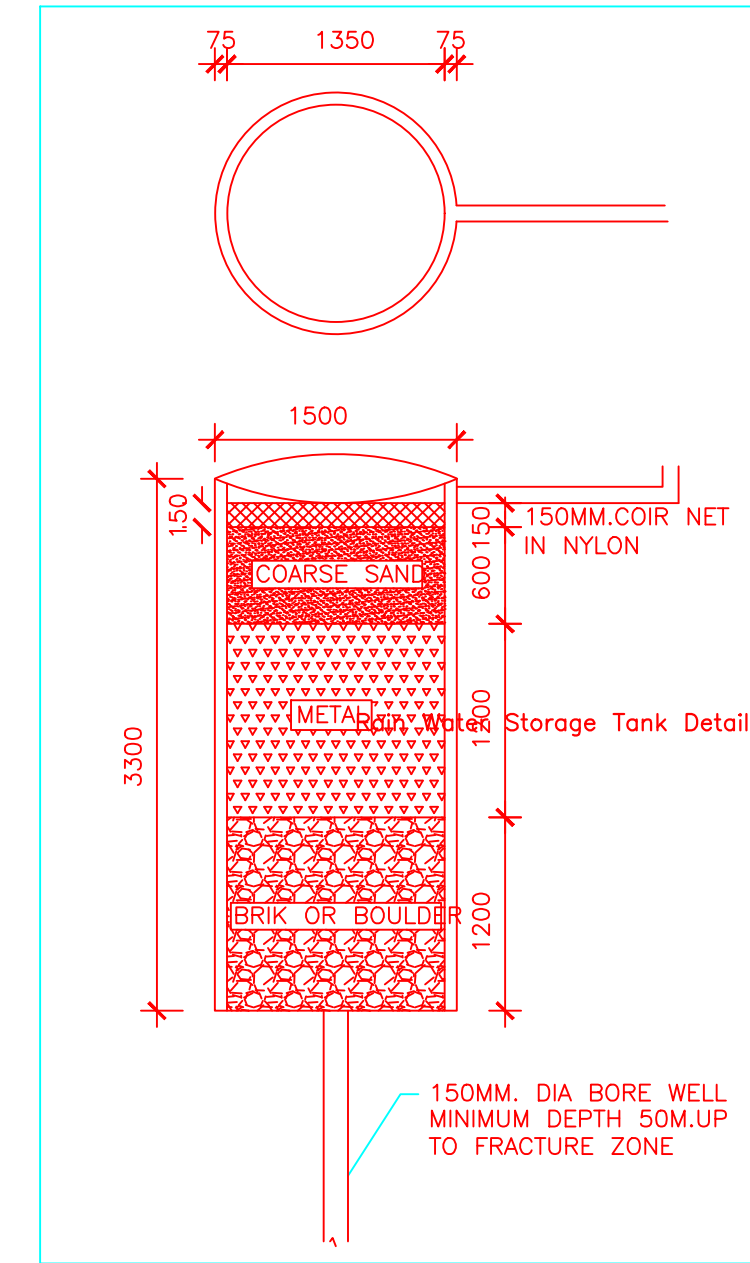
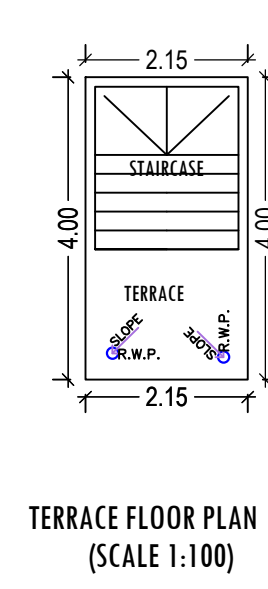
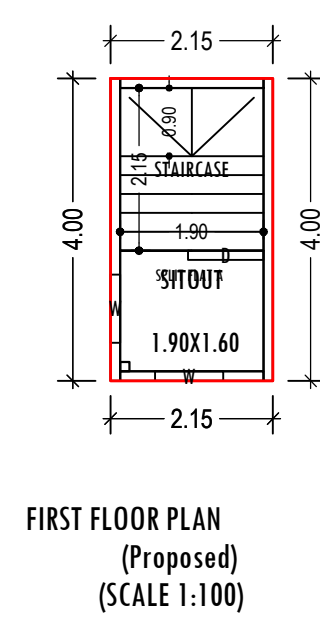
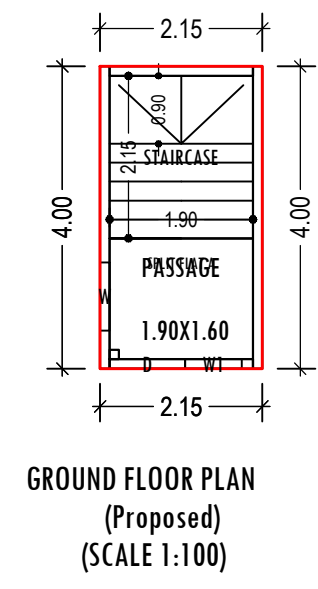
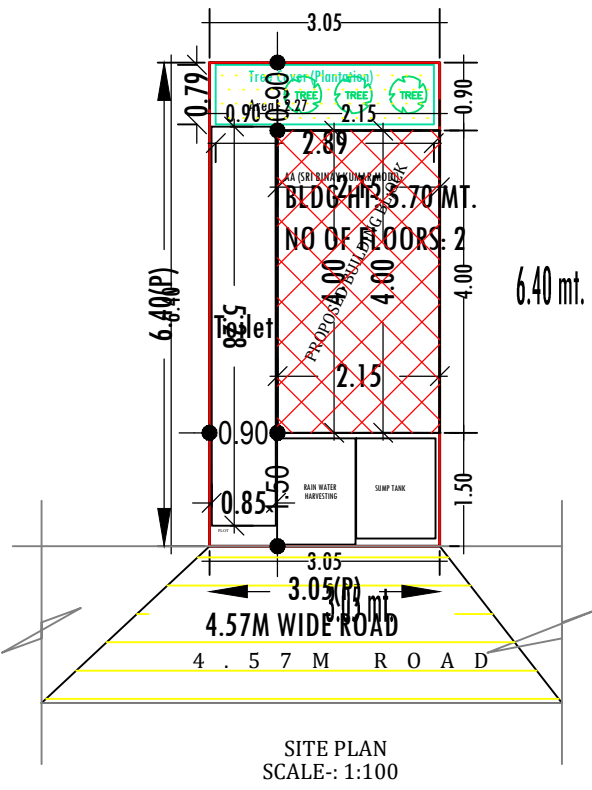

UnitBUA Table for Building :AA (SRI BINAY KUMAR MODI)

FLOOR	Name	UnitBUA Type	UnitBUA Area	Carpet Area	No. of Rooms	No. of Tenement
GROUND FLOOR PLAN	SPLIT FLAT A	FLAT	6.07	6.03	1	1
FIRST FLOOR PLAN	SPLIT FLAT A	FLAT	0.00	0.00	1	0
Total:	-	-	6.07	6.03	2	1

Building :AA (SRI BINAY KUMAR MODI)

Floor Name	Total Built Up Area (Sq.mt.)	Proposed FAR Area (Sq.mt.)	Total FAR Area (Sq.mt.)	Total Consumed Additional FAR Area (Sq.mt.)	Tnmt (No.)
Ground Floor	8.59	8.59	8.59	8.59	01
First Floor	8.59	8.59	8.59	8.59	00
Terrace Floor	0.00	0.00	0.00	0.00	00
Total:	17.18	17.18	17.18	17.18	01
Total Number of Same Buildings :	1				
Total :	17.18	17.18	17.18	17.18	01

SCHEDULE OF DOOR:

BUILDING NAME	NAME	LENGTH	HEIGHT	NOS
AA (SRI BINAY KUMAR MODI)	D	1.00	2.10	02

SCHEDULE OF WINDOW/VENTILATION:

BUILDING NAME	NAME	LENGTH	HEIGHT	NOS
AA (SRI BINAY KUMAR MODI)	W1	0.75	1.20	01
AA (SRI BINAY KUMAR MODI)	W	0.90	1.20	03

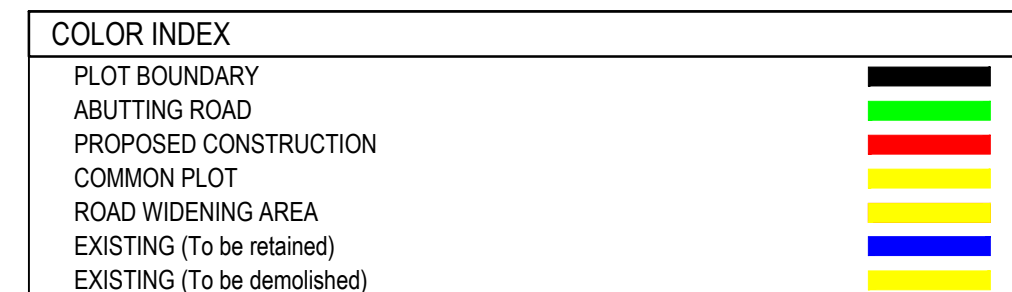

AREA STATEMENT	VERSION NO.:	1.0.66
JHUMRITILAIYA NAGAR PARISHAD	VERSION DATE:	16/10/2020
PROJECT DETAIL:		
Region: JHARKHAND URBAN LOCAL BODIES	Plot Use:	Residential
District: KODERMA	Plot SubUse:	Bungalow/ Dwelling / Non Apartment
Authority: JHUMRITILAIYA NAGAR PARISHAD	PlotNearby/ReligiousStructure:	NA
Inward_No: JNP/BI/0034/W10/2023	Plot/SubPlot No:	7457
Application Type: General Proposal	North: Plot No. - LAND OF RAJESH KUMAR	
Project Type: Building Permission	South: Plot No. - LAND OF ASHOK KUMAR BARNWAL	
Nature of Development: New	East: Road Width - 4.57M WIDE ROAD	
Location of Development Area: Old Area	West: Plot No. - OWN LAND OF VENDER VISHNU GOPAL RAJGARHIA	
AREA DETAILS:		
AREA OF PLOT (Minimum)	(A)	19.50
NET AREA OF PLOT(Gross Plot Area - Deduction from Gross Plot area)	(A-Deductions)	19.50
Deduction for Balance Plot Area(from Gross Plot Area)		
Common Plot		2.27
Total		2.27
BALANCE AREA OF PLOT(Net Plot Area - Recreational/Amenity space)	(A-Deductions)	17.23
PLOT AREA FOR COVERAGE(Net Plot Area)	(A-Deductions)	19.50
Plot Area for FAR (Net Plot Area + RoadWidening Area)	(A-Deductions)	19.50
COVERAGE CHECK		
Permissible Coverage area (70.00 %)		13.65
Proposed Coverage Area (44.06 %)		8.59
Total Prop. Coverage Area (44.06 %)		8.59
Balance coverage area (25.95 %)		5.06
FAR CHECK		
Perm. FAR Area (1.500)		29.25
Total Perm. FAR area		29.25
Residential FAR		17.17
Proposed FAR Area		17.17
Total Proposed FAR Area		17.17
Consumed FAR (Factor)		0.88
Balance FAR Area		12.08
BUILT UP AREA CHECK		
Total Proposed BuiltUp Area		17.18
ARCHITECT (Regd)		
ARCHITECT (Regd)		MD SHOAB ALAM
ENGINEER (Regd)		
ENGINEER (Regd)		
SUPERVISOR (Regd)		
SUPERVISOR (Regd)		
OWNER (Regd)		
OWNER (Regd)		SRI BINAY KUMAR MODI
DEVELOPMENT AUTHORITY		
DEVELOPMENT AUTHORITY		LOCAL BODY

Buildingwise Floor FAR Details

Floor Name	Building Name		Total	
	Proposed Built Up Area (Sq.mt.)	Proposed FAR Area (Sq.mt.)	Total Proposed Built Up Area (Sq.mt.)	Total FAR Area (Sq.mt.)
Ground Floor	8.59	8.59	8.59	8.59
First Floor	8.59	8.59	8.59	8.59
Terrace Floor	0.00	0.00	0.00	0.00
Total :	17.18	17.18	17.18	17.18

FAR & Tenement Details (Table 4c-1)

Building	No. of Same Bldg	Total Built Up Area (Sq.mt.)	Proposed FAR Area (Sq.mt.)	Total FAR Area (Sq.mt.)	Total Consumed Additional FAR Area (Sq.mt.)	Tnmt (No.)
AA (SRI BINAY KUMAR MODI)	1	17.18	17.18	17.18	17.18	01
Grand Total :	1	17.18	17.18	17.18	17.18	01

Building USE/SUBUSE Details

Building Name	Building Use	Building SubUse	Building Structure
AA (SRI BINAY KUMAR MODI)	Residential	Bungalow/ Dwelling / Non Apartment	Non-Highrise

LTP NAME AND SIGNATURE	STRUCTURAL ENG'S NAME AND SIGNATURE	BUILDER NAME AND SIGNATURE	DIGITAL SIGNATURE
MD SHOAB ALAM JNP/ENG/001/2017			