

SITE PLAN

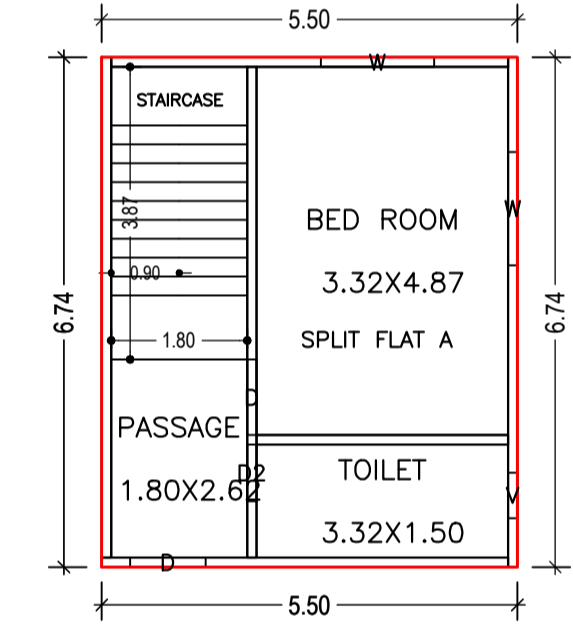

GROUND FLOOR PLAN (Proposed) (SCALE 1:100)

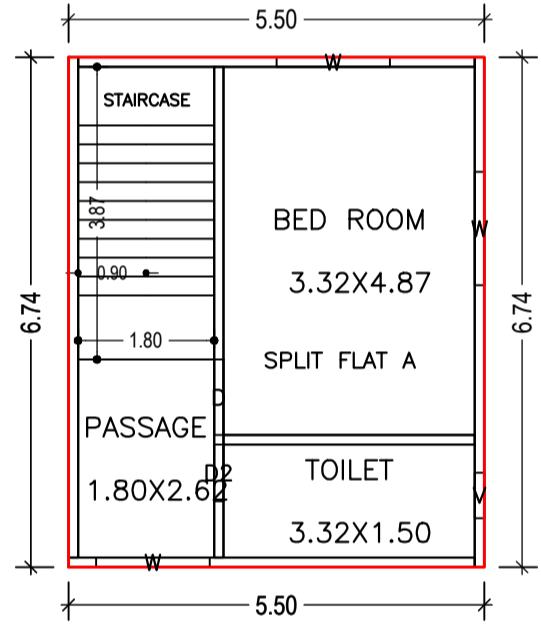

FIRST FLOOR PLAN (Proposed) (SCALE 1:100)

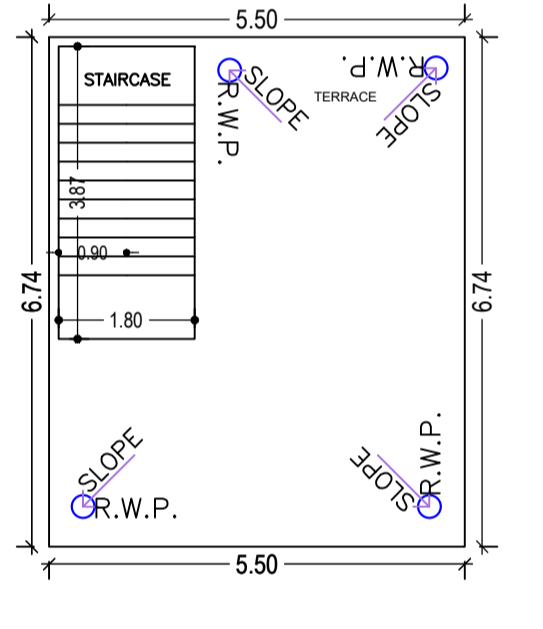

TERRACE FLOOR PLAN (Proposed) (SCALE 1:100)

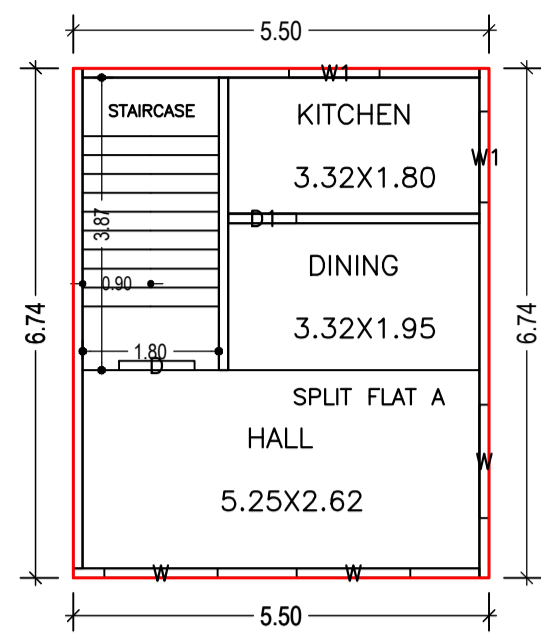

SECOND FLOOR PLAN (Proposed) (SCALE 1:100)

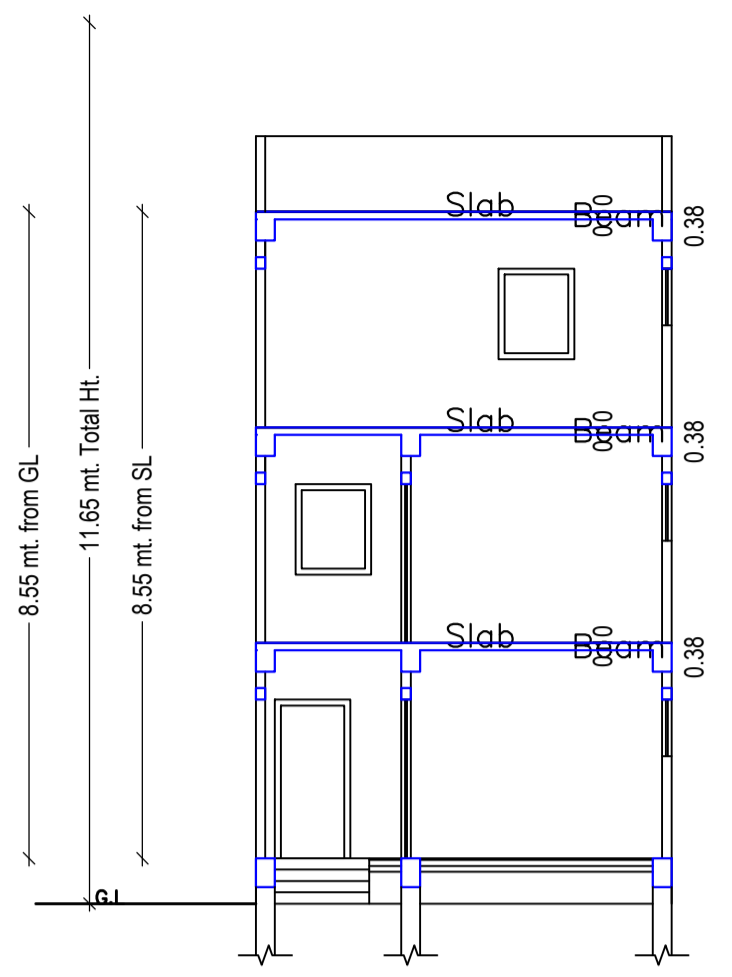

SECTION- X,X SCALE :- 1=100

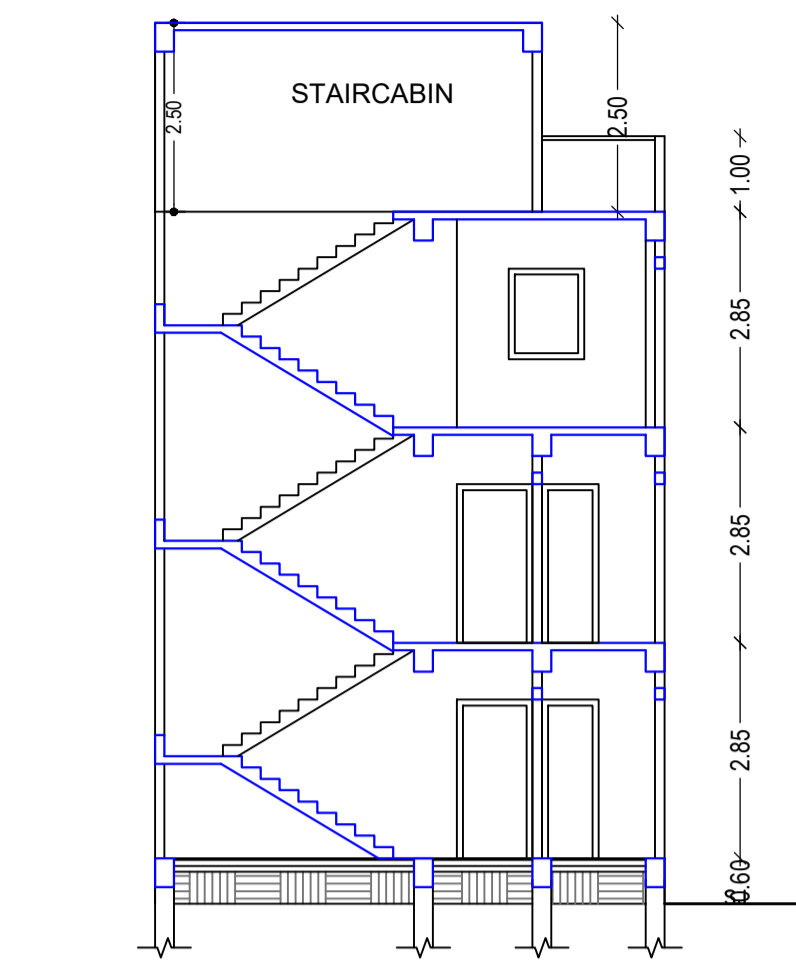

SECTION- Y,Y SCALE :- 1=100

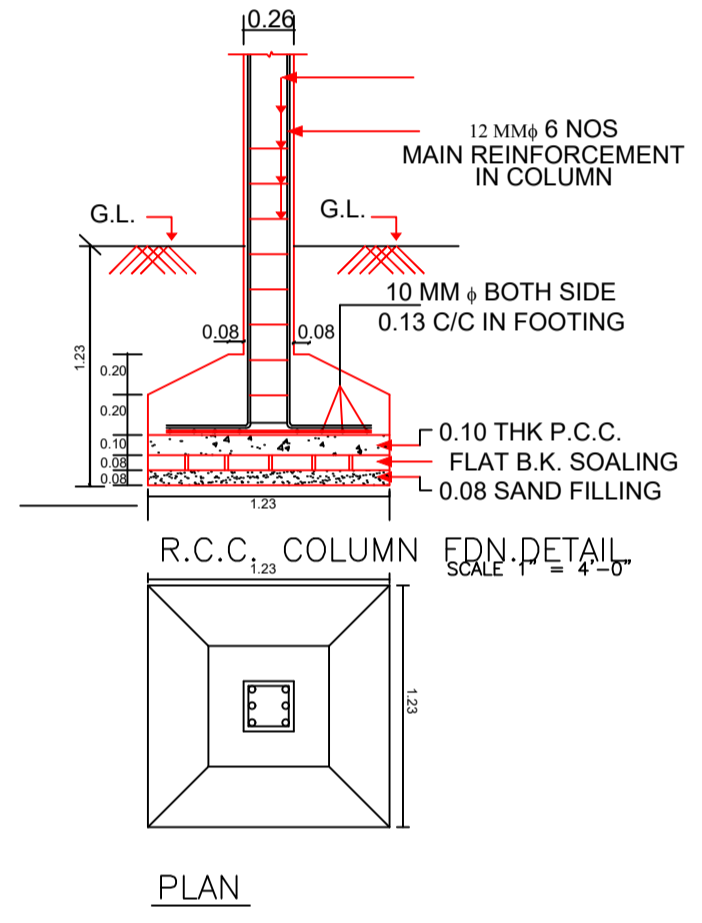

EDN DETAIL SCALE :- 4=1

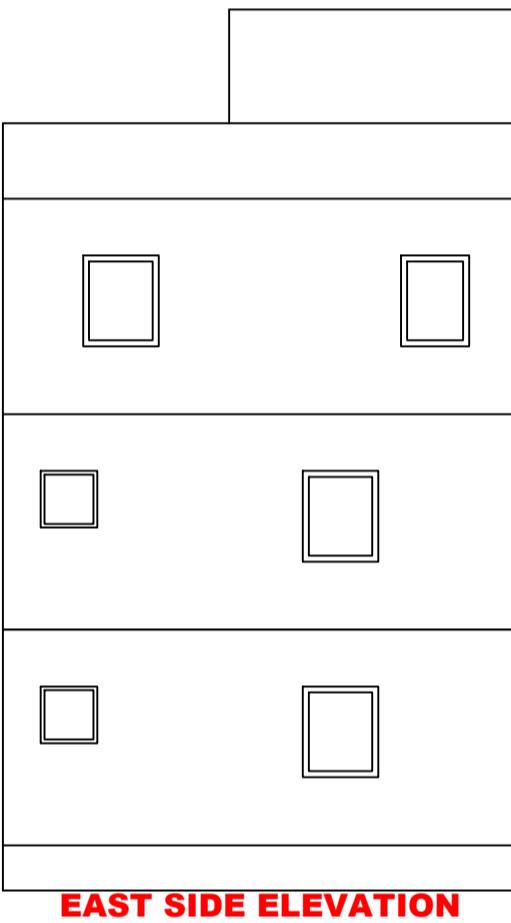

EAST SIDE ELEVATION SCALE :- 1=100

FAR & Tenement Details (Table 4c-1)

Building	No. of Same Bldg	Total Built Up Area (Sq.mt.)	Proposed FAR Area (Sq.mt.) Resi.	Total FAR Area (Sq.mt.)	Total Consumed Additional FAR Area (Sq.mt.)	Tnmt (No.)
AA (1 SRI ASHOK MODI 2 SRI SURENDRA BARNWAL 3 SRI ANIL KUMAR BARNWAL)	1	111.21	111.21	111.21	111.21	01
Grand Total :	1	111.21	111.21	111.21	111.21	01

Proposal Basic Information

Proposal File No.	JNP/BP/0033/W10/2023
Owner Name	1 ASHOK MODI 2 SURENDRA BARNWAL 3 ANIL KUMAR BARNWAL
Khata No	631
Plot No	7457
Village Name	Tilaiya
Use	Residential
SubUse	Bungalow/ Dwelling / Non Apartment

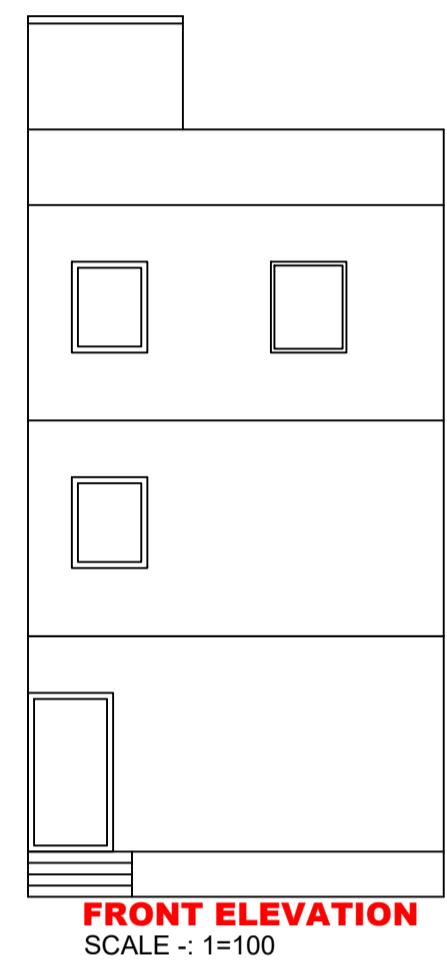

FRONT ELEVATION SCALE :- 1=100

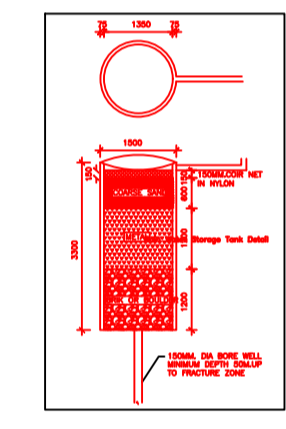
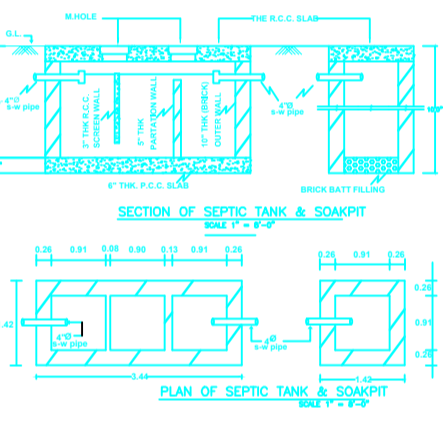

AREA STATEMENT JHUMRITILAIYA NAGAR PARISHAD

VERSION NO.: 1.0.66  
VERSION DATE: 16/10/2020

AREA DETAILS:		SQ. MT.
AREA OF PLOT (Minimum)	(A)	58.49
NET AREA OF PLOT (Gross Plot Area - Deduction from Gross Plot area)	(A-Deductions)	58.49
Deduction for Balance Plot Area (from Gross Plot Area)		
Common Plot		5.67
Total		5.67
BALANCE AREA OF PLOT (Net Plot Area - Recreational/Amenity space)	(A-Deductions)	52.82
PLOT AREA FOR COVERAGE (Net Plot Area)	(A-Deductions)	58.49
Plot Area for FAR (Net Plot Area + Road Widening Area)	(A-Deductions)	58.49
COVERAGE CHECK		
Permissible Coverage area ( 70.00 % )		40.94
Proposed Coverage Area ( 63.38 % )		37.07
Total Prop. Coverage Area ( 63.38 % )		37.07
Balance coverage area ( 6.62 % )		3.87
FAR CHECK		
Perm. FAR Area ( 2,000 )		116.98
Total Perm. FAR area		116.98
Residential FAR		111.20
Proposed FAR Area		111.20
Total Proposed FAR Area		111.20
Consumed FAR (Factor)		1.90
Balance FAR Area		5.78
BUILT UP AREA CHECK		
Total Proposed BuiltUp Area		111.21
ARCHITECT (Regd)	MD SHOAB ALAM	
ENGINEER (Regd)		
SUPERVISOR (Regd)		
OWNER (Regd)	1 ASHOK MODI 2 SURENDRA BARNWAL 3 ANIL KUMAR BARNWAL	
DEVELOPMENT AUTHORITY		LOCAL BODY

COLOR INDEX

PLOT BOUNDARY	Black
ABUTTING ROAD	Green
PROPOSED CONSTRUCTION	Red
COMMON PLOT	Yellow
ROAD WIDENING AREA	Blue
EXISTING (To be retained)	Light Blue
EXISTING (To be demolished)	Light Yellow

UnitBUA Table for Building :AA (1 SRI ASHOK MODI 2 SRI SURENDRA BARNWAL 3 SRI ANIL KUMAR BARNWAL)

FLOOR	Name	UnitBUA Type	UnitBUA Area	Carpet Area	No. of Rooms	No. of Tenement
GROUND FLOOR PLAN	SPLIT FLAT A	FLAT	79.86	78.61	3	1
FIRST FLOOR PLAN	SPLIT FLAT A	FLAT	0.00	0.00	3	0
SECOND FLOOR PLAN	SPLIT FLAT A	FLAT	0.00	0.00	3	0
Total:	-	-	79.86	78.61	9	1

Building :AA (1 SRI ASHOK MODI 2 SRI SURENDRA BARNWAL 3 SRI ANIL KUMAR BARNWAL)

Floor Name	Total Built Up Area (Sq.mt.)	Proposed FAR Area (Sq.mt.) Resi.	Total FAR Area (Sq.mt.)	Total Consumed Additional FAR Area (Sq.mt.)	Tnmt (No.)
Ground Floor	37.07	37.07	37.07	37.07	01
First Floor	37.07	37.07	37.07	37.07	00
Second Floor	37.07	37.07	37.07	37.07	00
Terrace Floor	0.00	0.00	0.00	0.00	00
Total :	111.21	111.21	111.21	111.21	01
Total Number of Same Buildings	1				
Total :	111.21	111.21	111.21	111.21	01

SCHEDULE OF DOOR:

BUILDING NAME	NAME	LENGTH	HEIGHT	NOS
AA (1 SRI ASHOK MODI 2 SRI SURENDRA BARNWAL 3 SRI ANIL KUMAR BARNWAL)	D2	0.75	2.10	02
AA (1 SRI ASHOK MODI 2 SRI SURENDRA BARNWAL 3 SRI ANIL KUMAR BARNWAL)	D1	0.90	2.10	01
AA (1 SRI ASHOK MODI 2 SRI SURENDRA BARNWAL 3 SRI ANIL KUMAR BARNWAL)	D	1.00	2.10	04

SCHEDULE OF WINDOW/VENTILATION:

BUILDING NAME	NAME	LENGTH	HEIGHT	NOS
AA (1 SRI ASHOK MODI 2 SRI SURENDRA BARNWAL 3 SRI ANIL KUMAR BARNWAL)	V	0.60	0.60	02
AA (1 SRI ASHOK MODI 2 SRI SURENDRA BARNWAL 3 SRI ANIL KUMAR BARNWAL)	W1	1.20	1.20	02
AA (1 SRI ASHOK MODI 2 SRI SURENDRA BARNWAL 3 SRI ANIL KUMAR BARNWAL)	W	1.50	1.20	08

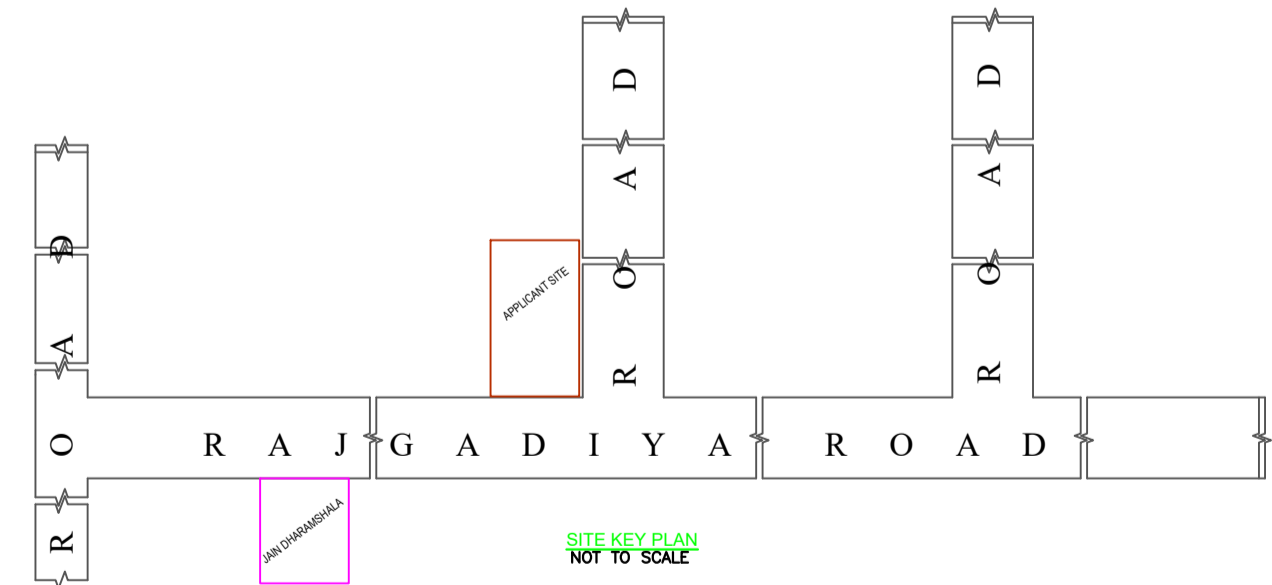

Buildingwise Floor FAR Details

Floor Name	Building Name		Total	
	Proposed Built Up Area (Sq.mt.)	Proposed FAR Area (Sq.mt.)	Total Proposed Built Up Area (Sq.mt.)	Total FAR Area (Sq.mt.)
Ground Floor	37.07	37.07	37.07	37.07
First Floor	37.07	37.07	37.07	37.07
Second Floor	37.07	37.07	37.07	37.07
Terrace Floor	0.00	0.00	0.00	0.00
Total :	111.21	111.21	111.21	111.21

Building USE/SUBUSE Details

Building Name	Building Use	Building SubUse	Building Structure
AA (1 SRI ASHOK MODI 2 SRI SURENDRA BARNWAL 3 SRI ANIL KUMAR BARNWAL)	Residential	Bungalow/ Dwelling / Non Apartment	Non-Highrise

LTP NAME AND SIGNATURE	STRUCTURAL ENG'S NAME AND SIGNATURE	BUILDER NAME AND SIGNATURE	DIGITAL SIGNATURE
MD SHOAB ALAM JNP/ENG/001/2017			