

(Scale - 1:400)

**FAR & Tenement Details (Table 4c-1)**

Building	No. of Same Bldg	Total Built Up Area (Sq.mt.)	Proposed FAR Area (Sq.mt.) Resi.	Total FAR Area (Sq.mt.)	Total Consumed Additional FAR Area (Sq.mt.)	Trmt (No.)
AA (SRI VIJAY YADAV)	1	144.40	144.40	144.40	144.40	01
<b>Grand Total :</b>	<b>1</b>	<b>144.40</b>	<b>144.40</b>	<b>144.40</b>	<b>144.40</b>	<b>01</b>

**Proposal Basic Information**

Proposal File No.	JNP/IBP/0041/W06/2023
Owner Name	SRI VIJAY YADAV
Khata No	92
Plot No	2178
Village Name	Asana
Use	Residential
SubUse	Bungalow/ Dwelling / Non Apartment

AREA STATEMENT	VERSION NO.: 1.0.66
JHUMRITILAIYA NAGAR PARISHAD	VERSION DATE: 16/10/2020
<b>PROJECT DETAIL:</b>	
Region: JHARKHAND URBAN LOCAL BODIES	Plot Use: Residential
District: KODERMA	Plot SubUse: Bungalow/ Dwelling / Non Apartment
Authority: JHUMRITILAIYA NAGAR PARISHAD	PlotNearby/ReligiousStructure: NA
Inward No: JNP/IBP/0041/W06/2023	Plot/SubPlot No: 2178
Application Type: General Proposal	North: Plot No. - VECANT LAND & HOUSE OF RAVINDRA SHARMA
Project Type: Building Permission	South: Road Width - 45M WIDE N.H.I ROAD
Nature of Development: New	East: Plot No. - DHARAM TELI
Location of Development Area: Old Area	West: Plot No. - MAINA DEVI JAIN
<b>AREA DETAILS:</b>	
AREA OF PLOT (Minimum)	(A) 72.64
NET AREA OF PLOT(Gross Plot Area - Deduction from Gross Plot area)	(A-Deductions) 72.64
Deduction for Balance Plot Area(from Gross Plot Area)	
Common Plot	6.98
Total	6.98
BALANCE AREA OF PLOT(Net Plot Area - Recreational/Amenity space)	(A-Deductions) 65.66
PLOT AREA FOR COVERAGE(Net Plot Area)	(A-Deductions) 72.64
Plot Area for FAR (Net Plot Area + RoadWidening Area)	(A-Deductions) 72.64
<b>COVERAGE CHECK</b>	
Permissible Coverage area ( 70.00 % )	50.85
Proposed Coverage Area ( 66.23 % )	48.11
Total Prop. Coverage Area ( 66.23 % )	48.11
Balance coverage area ( 3.77 % )	2.74
<b>FAR CHECK</b>	
Perm. FAR Area ( 2.000 )	145.28
Total Perm. FAR area	145.28
Residential FAR	144.40
Proposed FAR Area	144.40
Total Proposed FAR Area	144.40
Consumed FAR (Factor)	1.99
Balance FAR Area	0.88
<b>BUILT UP AREA CHECK</b>	
Total Proposed BuiltUp Area	144.40
ARCHITECT (Regd)	MD SHOAB ALAM
ENGINEER (Regd)	
SUPERVISOR (Regd)	
OWNER (Regd)	SRI VIJAY YADAV
DEVELOPMENT AUTHORITY	LOCAL BODY

COLOR INDEX	
PLOT BOUNDARY	Black
ABUTTING ROAD	Green
PROPOSED CONSTRUCTION	Red
COMMON PLOT	Yellow
ROAD WIDENING AREA	Yellow
EXISTING (To be retained)	Blue
EXISTING (To be demolished)	Yellow

**Buildingwise Floor FAR Details**

Floor Name	Building Name AA (SRI VIJAY YADAV)		Total	
	Proposed Built Up Area (Sq.mt.)	Proposed FAR Area (Sq.mt.)	Total Proposed Built Up Area (Sq.mt.)	Total FAR Area (Sq.mt.)
Basement Floor	48.11	48.11	48.11	48.11
Ground Floor	48.11	48.11	48.11	48.11
First Floor	24.09	24.09	24.09	24.09
Second Floor	24.09	24.09	24.09	24.09
Terrace Floor	0.00	0.00	0.00	0.00
<b>Total :</b>	<b>144.40</b>	<b>144.40</b>	<b>144.40</b>	<b>144.40</b>

**Building USE/SUBUSE Details**

Building Name	Building Use	Building SubUse	Building Structure
AA (SRI VIJAY YADAV)	Residential	Bungalow/ Dwelling / Non Apartment	Non-Highrise

LTP NAME AND SIGNATURE	STRUCTURAL ENG'S NAME AND SIGNATURE	BUILDER NAME AND SIGNATURE	DIGITAL SIGNATURE
MD SHOAB ALAM JNP/ENG/0001/2017			

Proposal Basic Information	
Proposal File No.	JNP/IBP/0041/W06/2023
Owner Name	SRI VIJAY YADAV
Khata No	92
Plot No	2178
Village Name	Asana
Use	Residential
SubUse	Bungalow/ Dwelling / Non Apartment

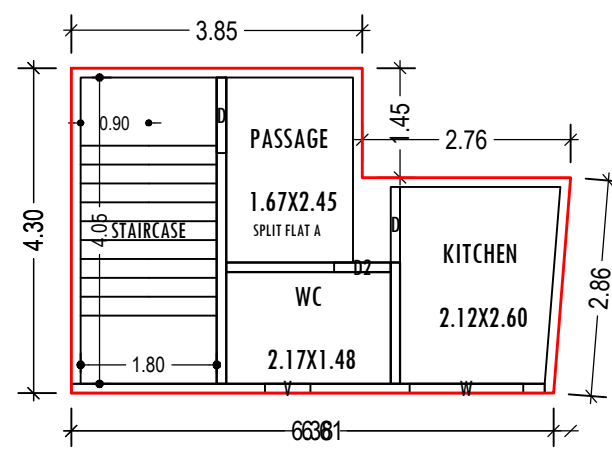
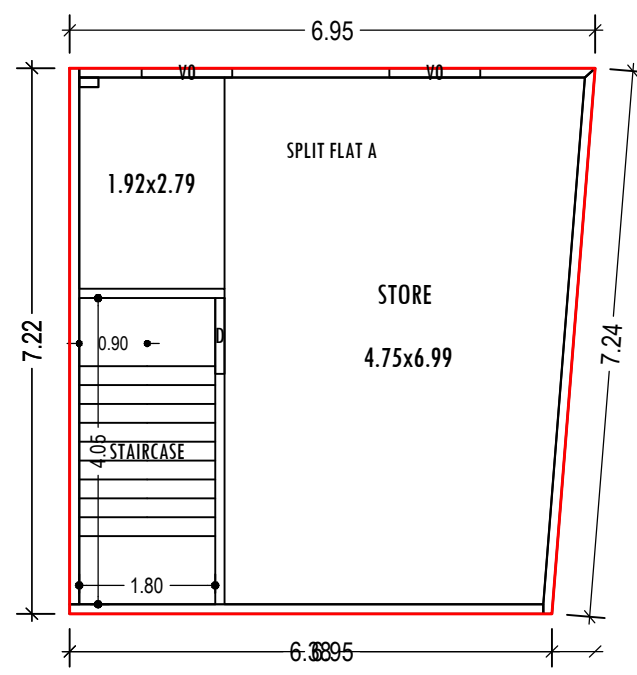

SECOND FLOOR PLAN  
(Proposed)  
(SCALE 1:100)

BASEMENT FLOOR PLAN  
(Proposed)  
(SCALE 1:100)

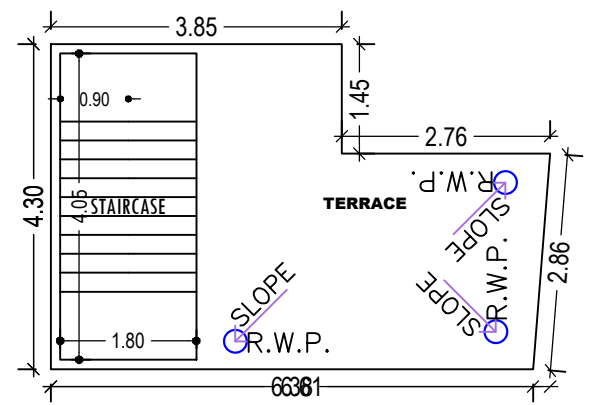
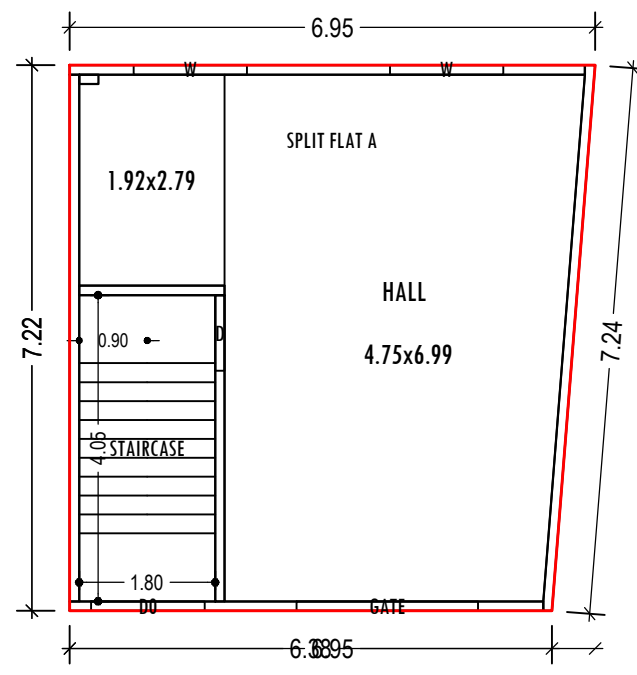

TERRACE FLOOR PLAN  
(SCALE 1:100)

GROUND FLOOR PLAN  
(Proposed)  
(SCALE 1:100)

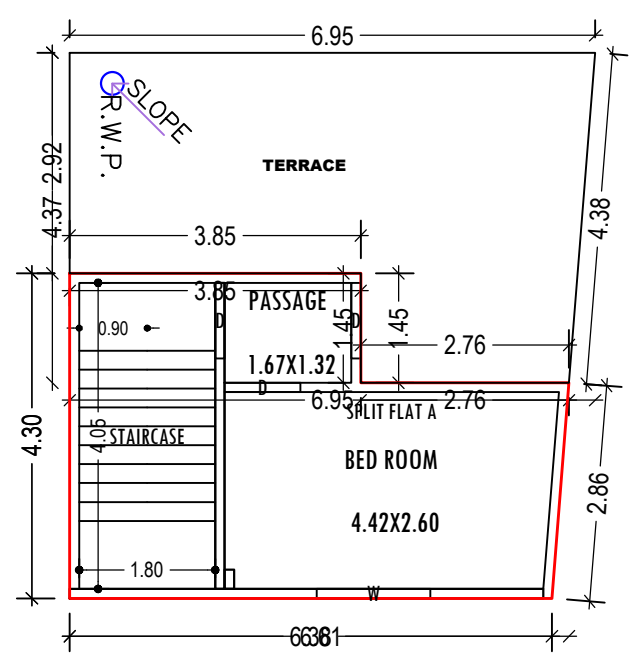

FIRST FLOOR PLAN  
(Proposed)  
(SCALE 1:100)

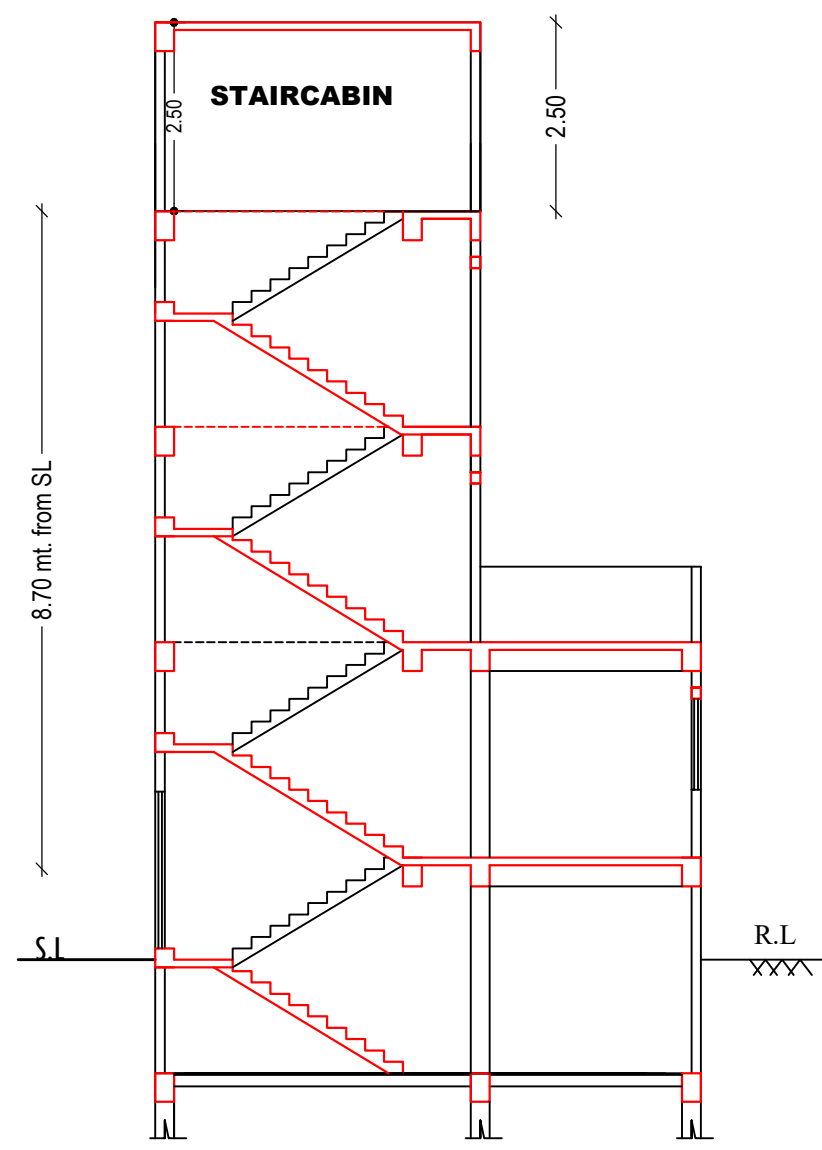

SECTION:- A,A'  
SCALE:- 1:100

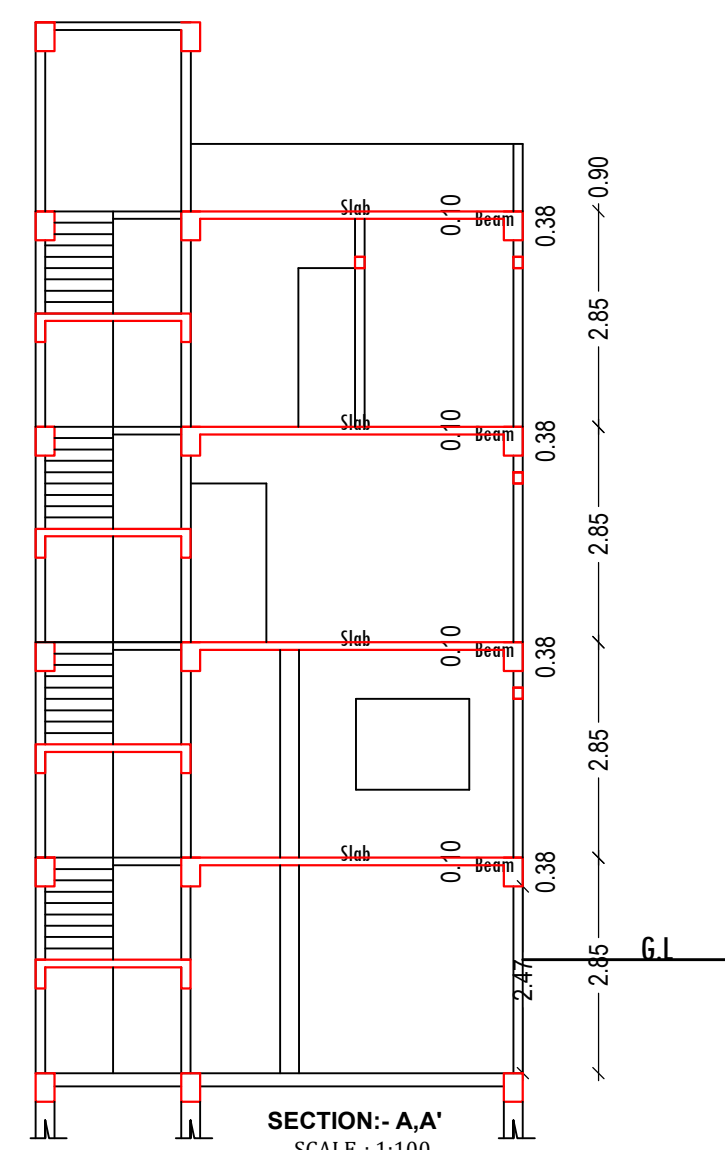

SECTION:- B,B'  
SCALE:- 1:100

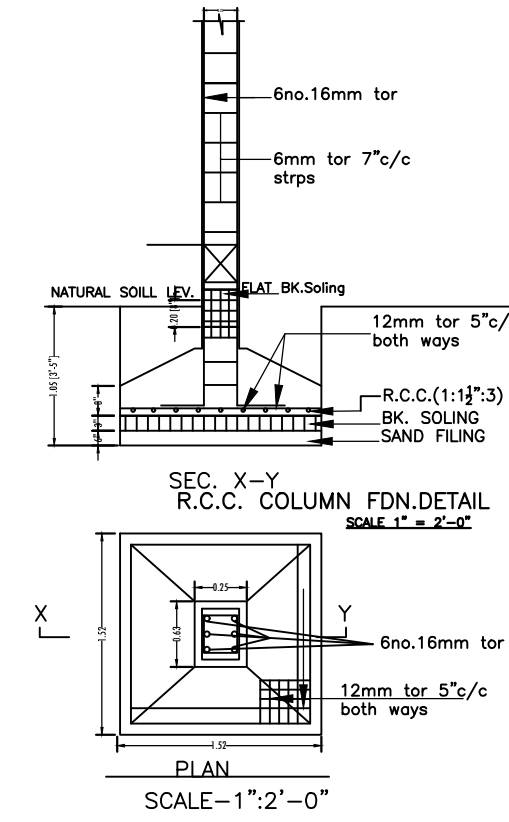

SEC. X-Y  
R.C.C. COLUMN FDN.DETAIL  
SCALE 1"=2'-0"

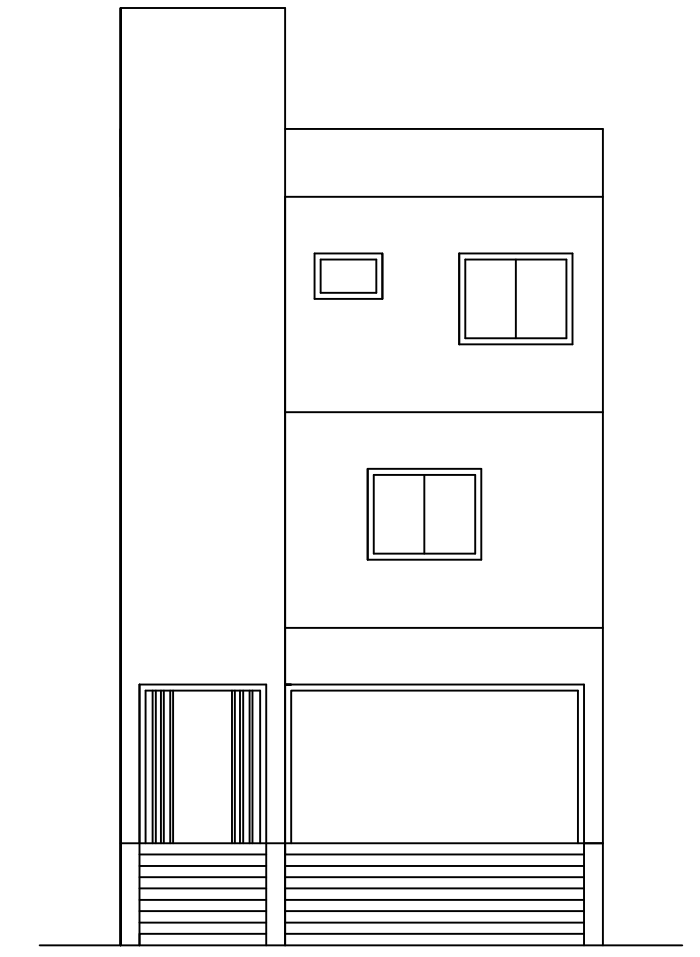

FRONT ELEVATION

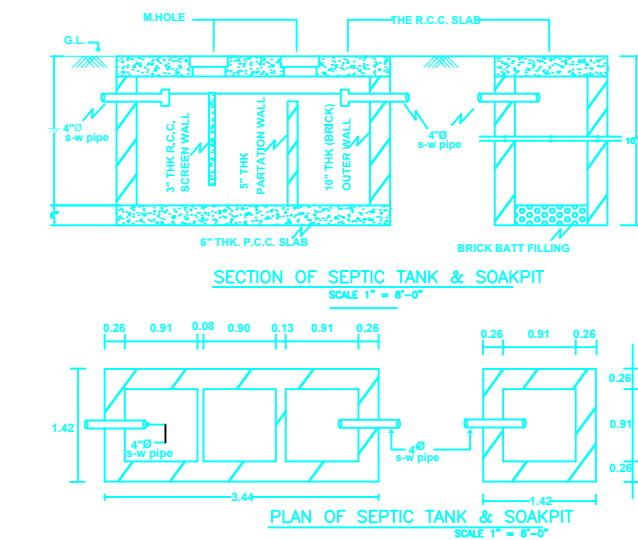

SECTION OF SEPTIC TANK & SOAKPIT  
PLAN OF SEPTIC TANK & SOAKPIT

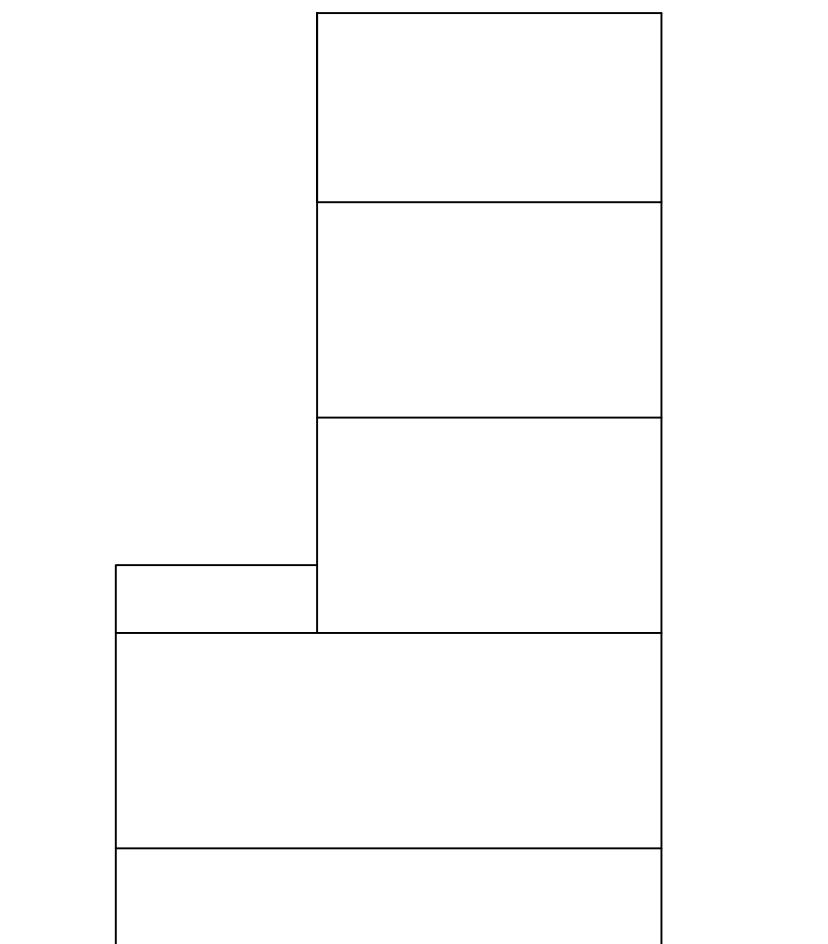

SIDE ELEVATION

Building -AA (SRI VIJAY YADAV)

Floor Name	Total Built Up Area (Sq.mt.)	Proposed FAR Area (Sq.mt.) Resi.	Total FAR Area (Sq.mt.)	Total Consumed Additional FAR Area (Sq.mt.)	Tnmt (No.)
Basement Floor	48.11	48.11	48.11	48.11	01
Ground Floor	48.11	48.11	48.11	48.11	00
First Floor	24.09	24.09	24.09	24.09	00
Second Floor	24.09	24.09	24.09	24.09	00
Terrace Floor	0.00	0.00	0.00	0.00	00
Total:	144.40	144.40	144.40	144.40	01
Total Number of Same Buildings	1				
Total:	144.40	144.40	144.40	144.40	01

SCHEDULE OF DOOR:

BUILDING NAME	NAME	LENGTH	HEIGHT	NOS
AA (SRI VIJAY YADAV)	D2	0.75	2.10	01
AA (SRI VIJAY YADAV)	D	1.00	2.10	07
AA (SRI VIJAY YADAV)	GATE	2.40	2.10	01

SCHEDULE OF WINDOW/VENTILATION:

BUILDING NAME	NAME	LENGTH	HEIGHT	NOS
AA (SRI VIJAY YADAV)	V	0.60	0.60	01
AA (SRI VIJAY YADAV)	V0	1.20	0.60	02
AA (SRI VIJAY YADAV)	W	1.50	1.20	04

UnitBUA Table for Building -AA (SRI VIJAY YADAV)

FLOOR	Name	UnitBUA Type	UnitBUA Area	Carpet Area	No. of Rooms	No. of Tenement
BASEMENT FLOOR PLAN	SPLIT FLAT A	FLAT	100.64	100.07	1	1
GROUND FLOOR PLAN	SPLIT FLAT A	FLAT	0.00	0.00	1	0
FIRST FLOOR PLAN	SPLIT FLAT A	FLAT	0.00	0.00	2	0
SECOND FLOOR PLAN	SPLIT FLAT A	FLAT	0.00	0.00	3	0
Total:	-	-	100.64	100.07	7	1

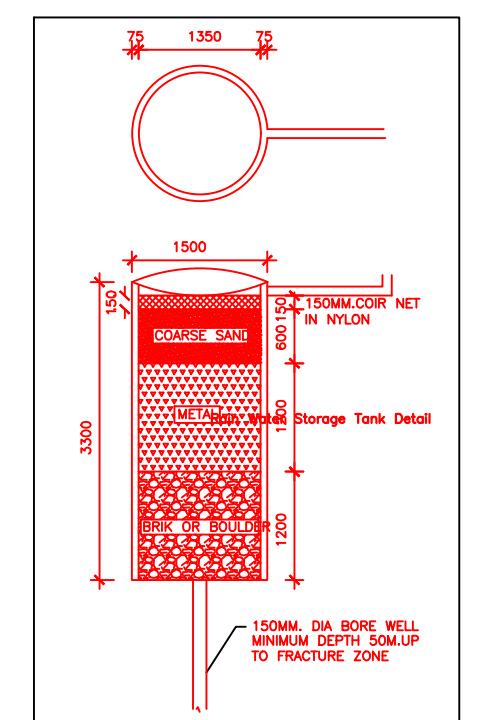
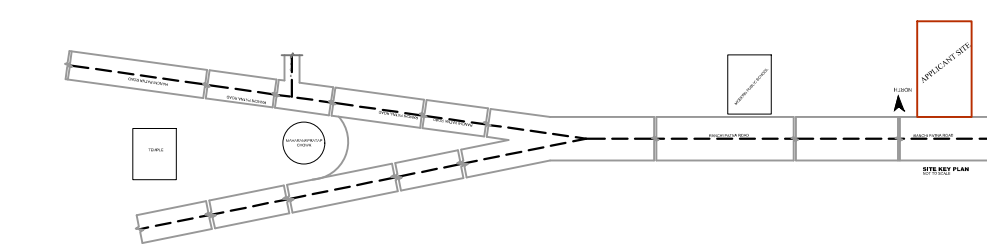

LTP NAME AND SIGNATURE	STRUCTURAL ENG'S NAME AND SIGNATURE	BUILDER NAME AND SIGNATURE	DIGITAL SIGNATURE
MD SHOAB ALAM JNP/ENG/0001/2017			