

SITE PLAN
SCALE :- 1=100

SITE PLAN

AREA STATEMENT		VERSION NO.: 1.0.66
JHUMRITILAYA NAGAR		VERSION DATE: 16/10/2020
PARISHAD		
PROJECT DETAIL:		
Region: JHARKHAND URBAN LOCAL BODIES	Plot Use: Residential	
District: KODERMA	Plot SubUse: Bungalow/ Dwelling / Non Apartment	
Authority: JHUMRITILAYA NAGAR PARISHAD	PlotNearby/ReligiousStructure: NA	
Inward_No: JNP/BB/0039/W06/2023	Plot/SubPlot No: 2134	
Application Type: General Proposal	North: Plot No. - MD JAHIR	
Project Type: Building Permission	South: Road Width - OWN LAND OF VENDOR & 1.22M WIDE RASTA	
Nature of Development: New	East: Plot No. - HABIB MIYAN	
Location of Development Area: Old Area	West: Plot No. - GULAM ANSAR/NUZHAT PARWEEN	
AREA DETAILS:		
AREA OF PLOT (Minimum)	(A)	200.15
Deduction for NetPlot Area		
Road Widening Area		23.40
Total		23.40
NET AREA OF PLOT(Gross Plot Area - Deduction from Gross Plot area)	(A-Deductions)	176.75
Deduction for Balance Plot Area(from Gross Plot Area)		
Road Widening Area		23.40
Common Plot		20.77
Total		44.17
BALANCE AREA OF PLOT(Net Plot Area - Recreational/Amenity space)	(A-Deductions)	155.98
PLOT AREA FOR COVERAGE(Net Plot Area)	(A-Deductions)	176.75
Plot Area for FAR (Net Plot Area + RoadWidening Area)	(A-Deductions)	176.75
COVERAGE CHECK		
Permissible Coverage area (70.00 %)		123.72
Proposed Coverage Area (53.25 %)		94.11
Total Prop. Coverage Area (53.25 %)		94.11
Balance coverage area (16.75 %)		29.61
FAR CHECK		
Perm. FAR Area (1.200)		212.10
Total Perm. FAR area		212.10
Residential FAR		188.23
Proposed FAR Area		188.23
Total Proposed FAR Area		188.23
Consumed FAR (Factor)		1.06
Balance FAR Area		23.87
BUILT UP AREA CHECK		
Total Proposed BuiltUp Area		188.22
ARCHITECT (Regd)	MD SHOAB ALAM	
ENGINEER (Regd)		
SUPERVISOR (Regd)		
OWNER (Regd)	1 SHABNAM YASMIN 2 ASMA KHATUN	
DEVELOPMENT AUTHORITY		LOCAL BODY

COLOR INDEX	
PLOT BOUNDARY	
ABUTTING ROAD	
PROPOSED CONSTRUCTION	
COMMON PLOT	
ROAD WIDENING AREA	
EXISTING (To be retained)	
EXISTING (To be demolished)	

Buildingwise Floor FAR Details

Floor Name	Building Name		Total	
	Proposed Built Up Area (Sq.mt.)	Proposed FAR Area (Sq.mt.)	Total Proposed Built Up Area (Sq.mt.)	Total FAR Area (Sq.mt.)
Ground Floor	94.11	94.11	94.11	94.11
First Floor	94.11	94.11	94.11	94.11
Terrace Floor	0.00	0.00	0.00	0.00
Total:	188.22	188.22	188.22	188.22

Building USE/SUBUSE Details

Building Name	Building Use	Building SubUse	Building Structure
AA (1 SHABNAM YASMIN 2 ASMA KHATUN)	Residential	Bungalow/ Dwelling / Non Apartment	Non-Highrise

FAR & Tenement Details (Table 4c-1)

Building	No. of Same Bldg	Total Built Up Area (Sq.mt.)	Proposed FAR	Total FAR Area (Sq.mt.)	Total Consumed Additional FAR Area (Sq.mt.)	Tmmt (No.)
			Resi.			
AA (1 SHABNAM YASMIN 2 ASMA KHATUN)	1	188.22	188.22	188.22	188.22	01
Grand Total :	1	188.22	188.22	188.22	188.22	01

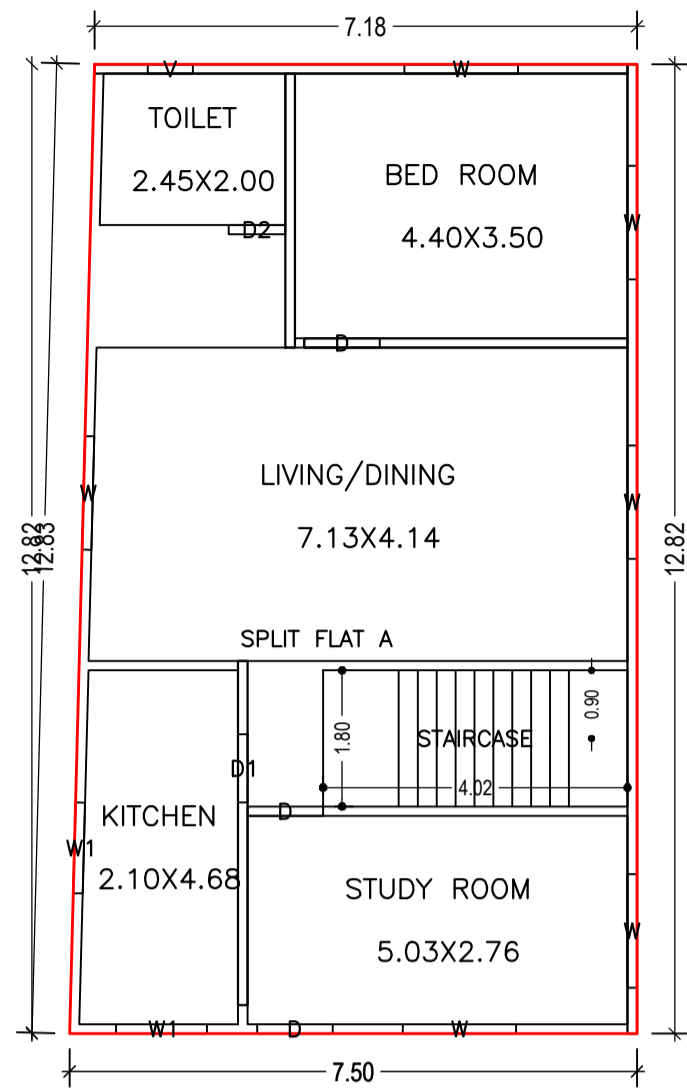

GROUND FLOOR PLAN
(Proposed)
(SCALE 1:100)

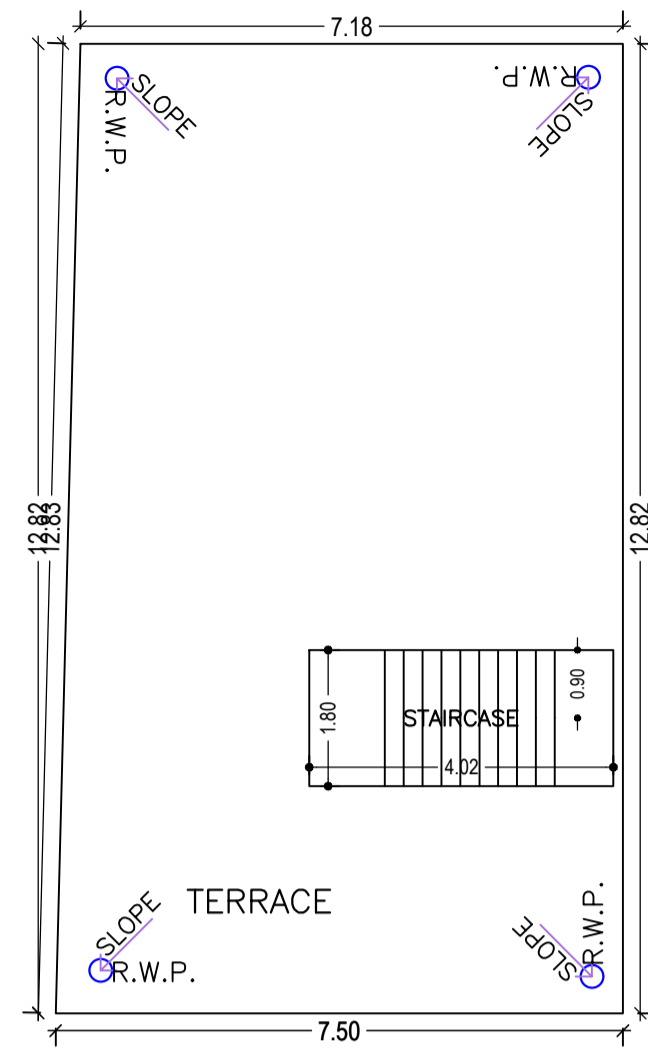

TERRACE FLOOR PLAN
(SCALE 1:100)

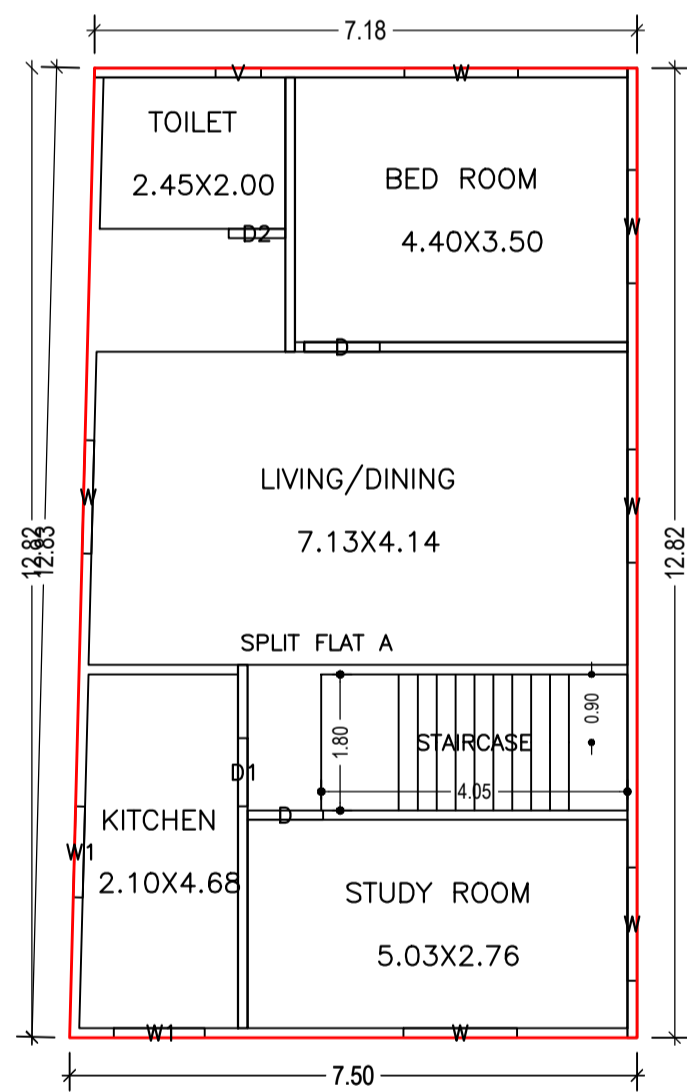

FIRST FLOOR PLAN
(Proposed)
(SCALE 1:100)

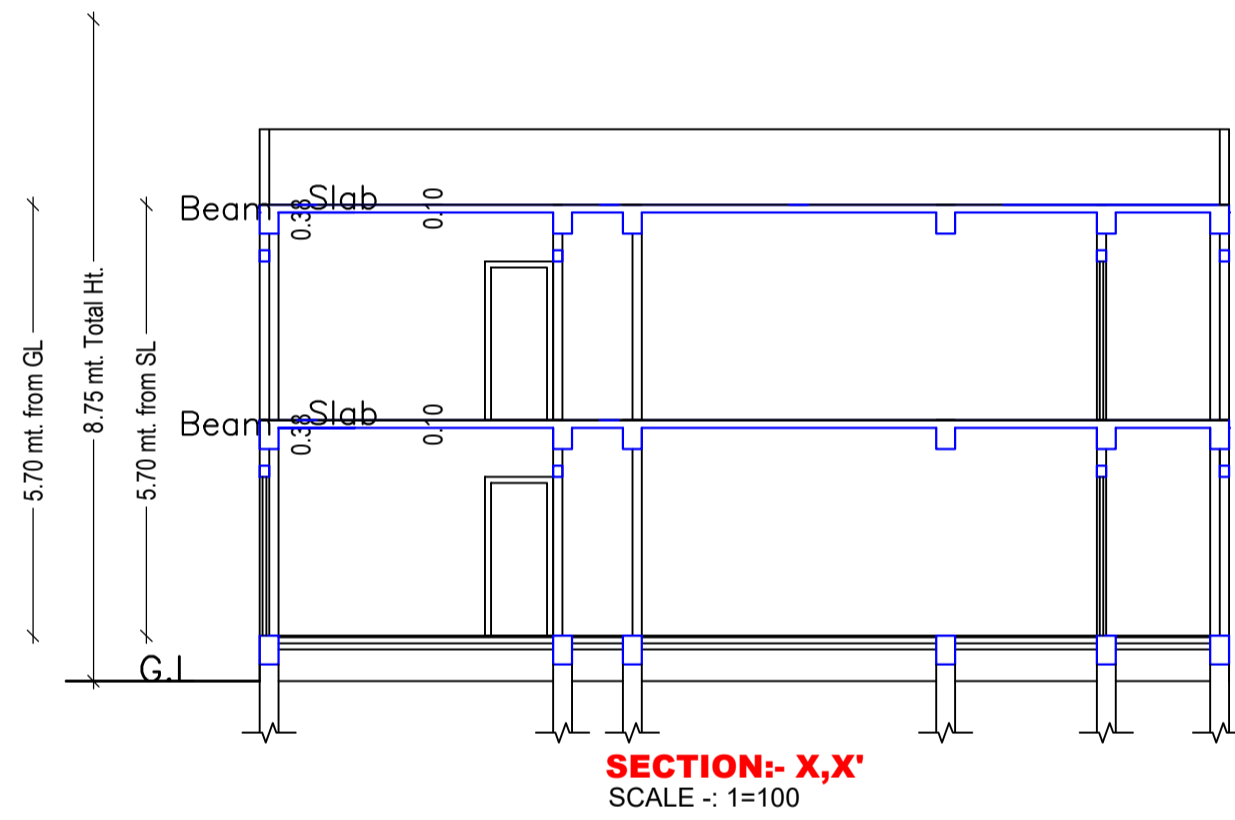

SECTION - X,X'
SCALE : 1=100

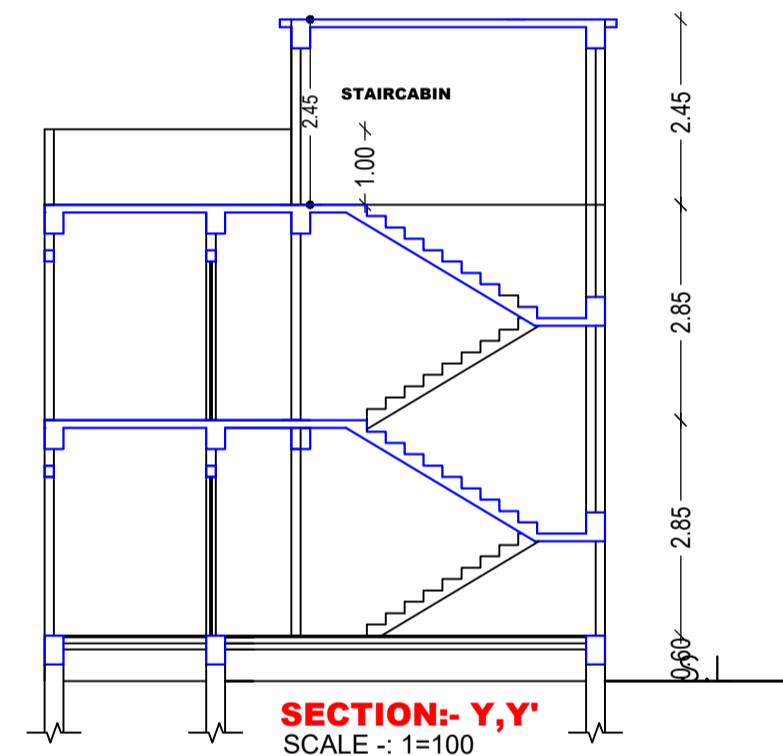

SECTION - Y,Y'
SCALE : 1=100

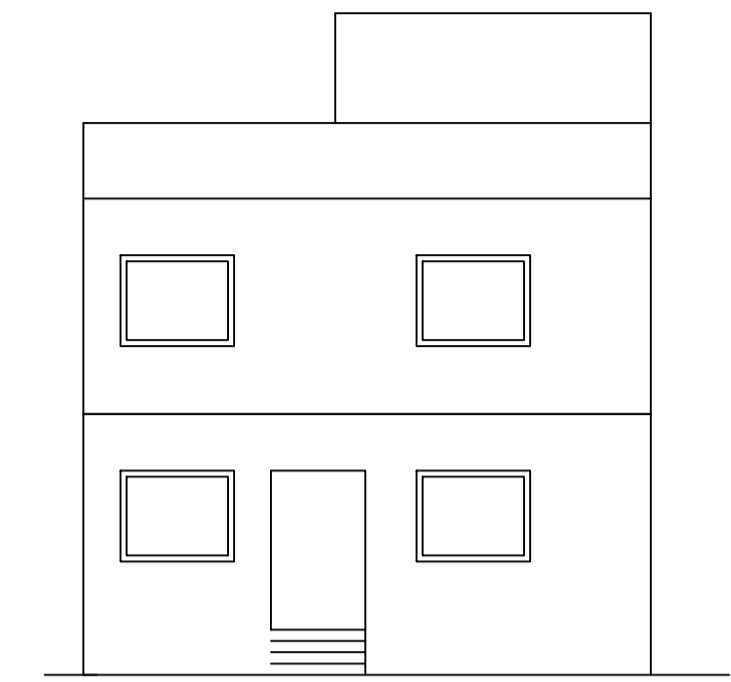

FRONT ELEVATION
SCALE : 1=100

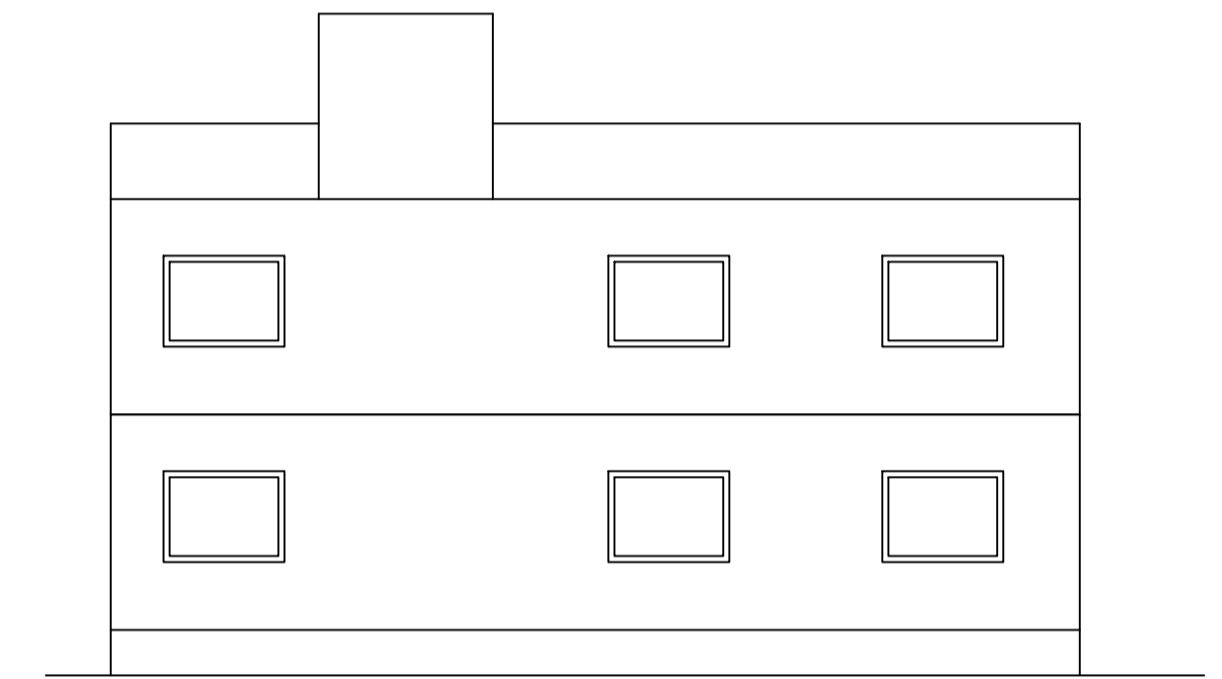

SIDE ELEVATION
SCALE : 1=100

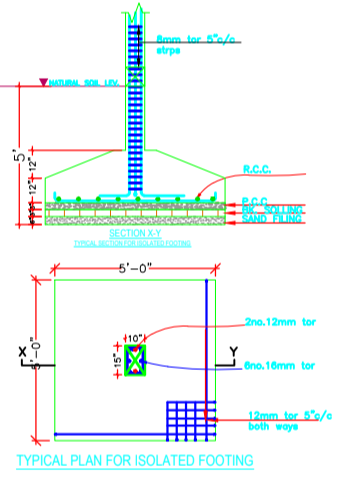

TYPICAL PLAN FOR ISOLATED FOOTING

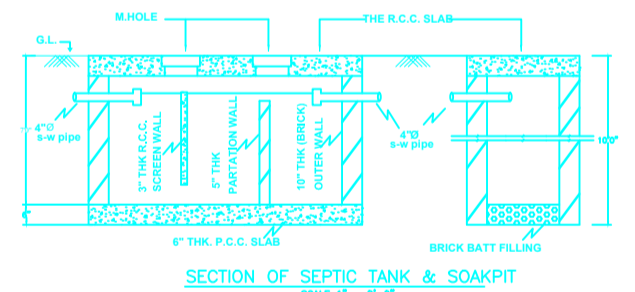

SECTION OF SEPTIC TANK & SOAKPIT

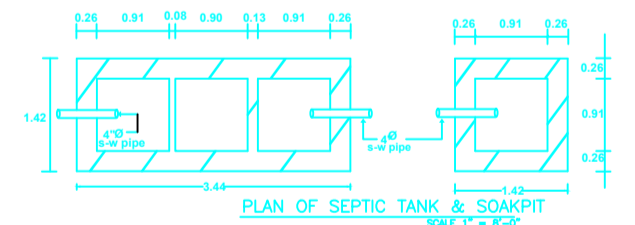

PLAN OF SEPTIC TANK & SOAKPIT

SCHEDULE OF DOOR:

BUILDING NAME	NAME	LENGTH	HEIGHT	NOS
AA (1 SHABNAM YASMIN 2 ASMA KHATUN)	D2	0.75	2.10	02
AA (1 SHABNAM YASMIN 2 ASMA KHATUN)	D1	0.90	2.10	02
AA (1 SHABNAM YASMIN 2 ASMA KHATUN)	D	1.00	2.10	05

SCHEDULE OF WINDOW/VENTILATION:

BUILDING NAME	NAME	LENGTH	HEIGHT	NOS
AA (1 SHABNAM YASMIN 2 ASMA KHATUN)	V	0.60	0.60	02
AA (1 SHABNAM YASMIN 2 ASMA KHATUN)	W1	1.20	1.20	04
AA (1 SHABNAM YASMIN 2 ASMA KHATUN)	W	1.50	1.20	12

UnitBUA Table for Building :AA (1 SHABNAM YASMIN 2 ASMA KHATUN)

FLOOR	Name	UnitBUA Type	UnitBUA Area	Carpet Area	No. of Rooms	No. of Tenement
GROUND FLOOR PLAN	SPLIT FLAT A	FLAT	161.72	158.57	5	1
FIRST FLOOR PLAN	SPLIT FLAT A	FLAT	0.00	0.00	5	0
Total:	-	-	161.72	158.57	10	1

Building :AA (1 SHABNAM YASMIN 2 ASMA KHATUN)

Floor Name	Total Built Up Area (Sq.mt.)	Proposed FAR Area (Sq.mt.)	Total FAR Area (Sq.mt.)	Total Consumed Additional FAR Area (Sq.mt.)	Tnmt (No.)
Ground Floor	94.11	94.11	94.11	94.11	01
First Floor	94.11	94.11	94.11	94.11	00
Terrace Floor	0.00	0.00	0.00	0.00	00
Total:	188.22	188.22	188.22	188.22	01
Total Number of Same Buildings	1				
Total:	188.22	188.22	188.22	188.22	01

