

SITE PLAN
SCALE:- 1:100

SITE PLAN

FAR & Tenement Details (Table 4c-1)

Building	No. of Same Bldg	Total Built Up Area (Sq.mt.)	Deductions (Area in Sq.mt.)	Proposed FAR Area (Sq.mt.)	Total FAR Area (Sq.mt.)	Total Consumed Additional FAR Area (Sq.mt.)	Tnmt (No.)
AA (SRI SANUJ YADAV)	1	282.03	30.78	251.25	251.25	251.25	01
Grand Total :	1	282.03	30.78	251.25	251.25	251.25	01

Proposal Basic Information

Proposal File No.	JNP/IBP/0056/W07/2023
Owner Name	SRI SANUJ YADAV
Khata No	01
Plot No	147
Village Name	Jhalpo
Use	Residential
SubUse	Bungalow/ Dwelling / Non Apartment

AREA STATEMENT	VERSION NO. : 1.0.66
JHUMRITLAIYA NAGAR PARISHAD	VERSION DATE: 16/10/2020
PROJECT DETAIL:	
Region: JHARKHAND URBAN LOCAL BODIES	Plot Use: Residential
District: KODERMA	Plot SubUse: Bungalow/ Dwelling / Non Apartment
Authority: JHUMRITLAIYA NAGAR PARISHAD	PlotNearbyReligiousStructure: NA
Inward No: JNP/IBP/0056/W07/2023	PlotSubPlot No: 147
Application Type: General Proposal	North: Plot No. - PART OF PLOT NO 147
Project Type: Building Permission	South: Plot No. - MANUJ YADAV
Nature of Development: New	East: Road Width- 6.10M WIDE KATCHA ROAD
Location of Development Area: Old Area	West: Plot No. - ROHIT KUMAR RAJGARHA
AREA DETAILS:	
AREA OF PLOT (Minimum)	(A) 158.41
NET AREA OF PLOT(Gross Plot Area - Deduction from Gross Plot area)	(A-Deductions) 158.41
Deduction for Balance Plot Area(from Gross Plot Area)	
Common Plot	15.45
Total	15.45
BALANCE AREA OF PLOT(Net Plot Area - Recreational/Amenity space)	(A-Deductions) 142.96
PLOT AREA FOR COVERAGE(Net Plot Area)	(A-Deductions) 158.41
Plot Area for FAR (Net Plot Area + RoadWidening Area)	(A-Deductions) 158.41
COVERAGE CHECK	
Permissible Coverage area (70.00 %)	110.89
Proposed Coverage Area (59.35 %)	94.01
Total Prop. Coverage Area (59.35 %)	94.01
Balance coverage area (10.66 %)	16.88
FAR CHECK	
Perm. FAR Area (2.000)	316.82
Total Perm. FAR area	316.82
Residential FAR	251.25
Proposed FAR Area	251.25
Total Proposed FAR Area	251.25
Consumed FAR (Factor)	1.59
Balance FAR Area	65.57
BUILT UP AREA CHECK	
Total Proposed BuiltUp Area	282.03
ARCHITECT (Regd)	MD SHOAB ALAM
ENGINEER (Regd)	
SUPERVISOR (Regd)	
OWNER (Regd)	SRI SANUJ YADAV
DEVELOPMENT AUTHORITY	
	LOCAL BODY

COLOR INDEX	
PLOT BOUNDARY	Black
ABUTTING ROAD	Green
PROPOSED CONSTRUCTION	Red
COMMON PLOT	Yellow
ROAD WIDENING AREA	Blue
EXISTING (To be retained)	Blue
EXISTING (To be demolished)	Yellow

Buildingwise Floor FAR Details

Floor Name	Building Name AA (SRI SANUJ YADAV)		Total	
	Proposed Built Up Area (Sq.mt.)	Proposed FAR Area (Sq.mt.)	Total Proposed Built Up Area (Sq.mt.)	Total FAR Area (Sq.mt.)
Ground Floor	94.01	63.23	94.01	63.23
First Floor	94.01	94.01	94.01	94.01
Second Floor	94.01	94.01	94.01	94.01
Terrace Floor	0.00	0.00	0.00	0.00
Total :	282.03	251.25	282.03	251.25

Building USE/SUBUSE Details

Building Name	Building Use	Building SubUse	Building Structure
AA (SRI SANUJ YADAV)	Residential	Bungalow/ Dwelling / Non Apartment	Non-Highrise

LTP NAME AND SIGNATURE	STRUCTURAL ENG'S NAME AND SIGNATURE	BUILDER NAME AND SIGNATURE	DIGITAL SIGNATURE
MD SHOAB ALAM JNP/ENG/001/2017			

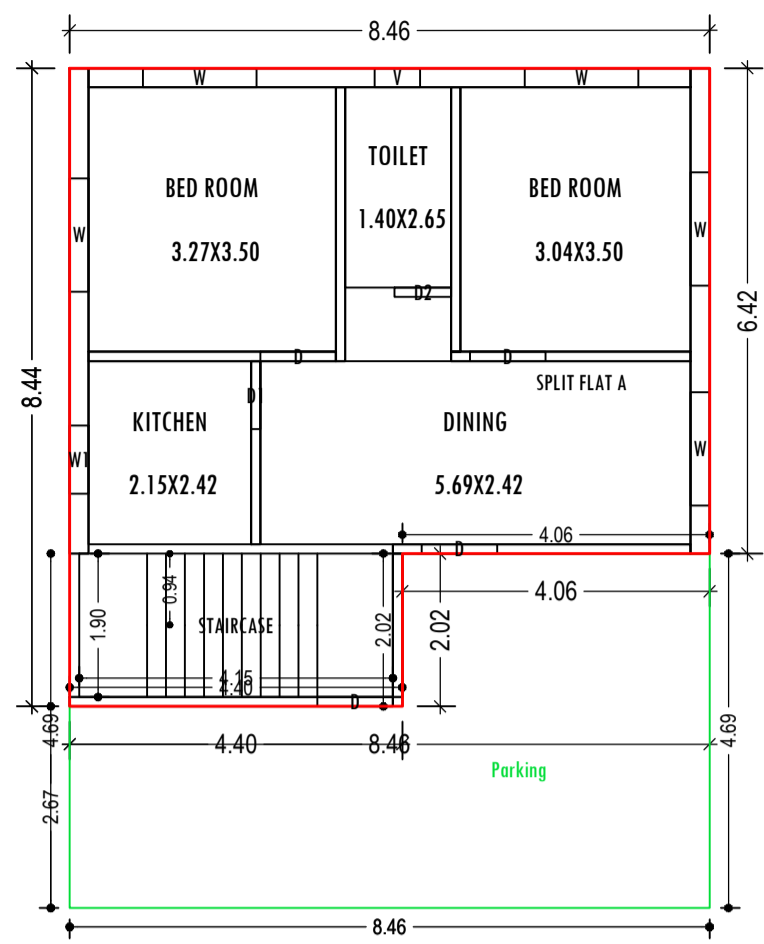

GROUND FLOOR PLAN
(Proposed)
(SCALE 1:100)

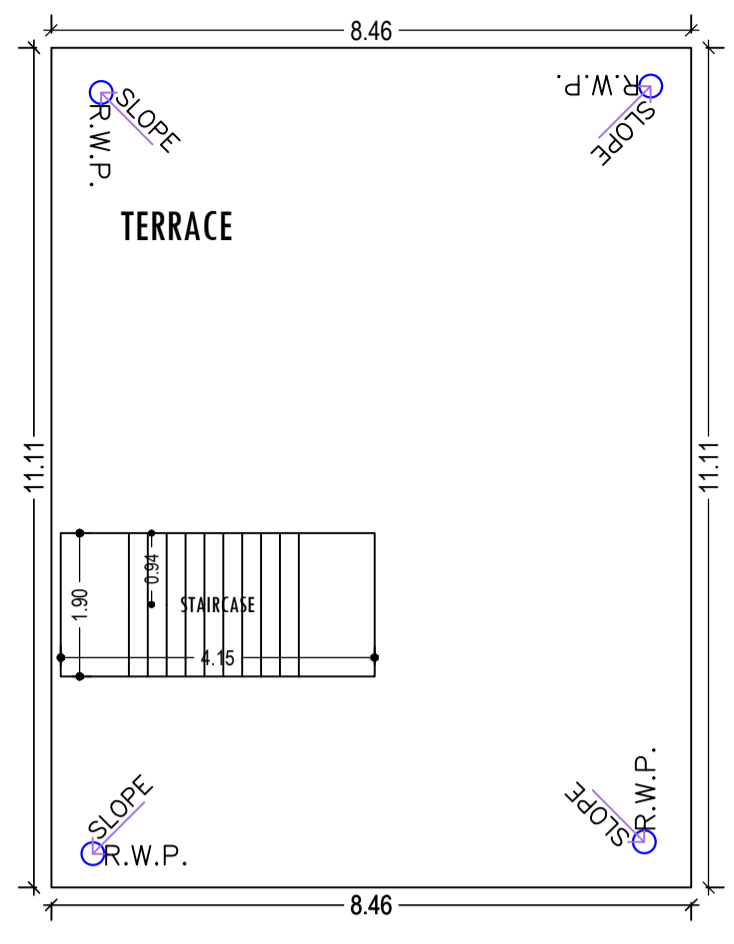

TERRACE FLOOR PLAN
(SCALE 1:100)

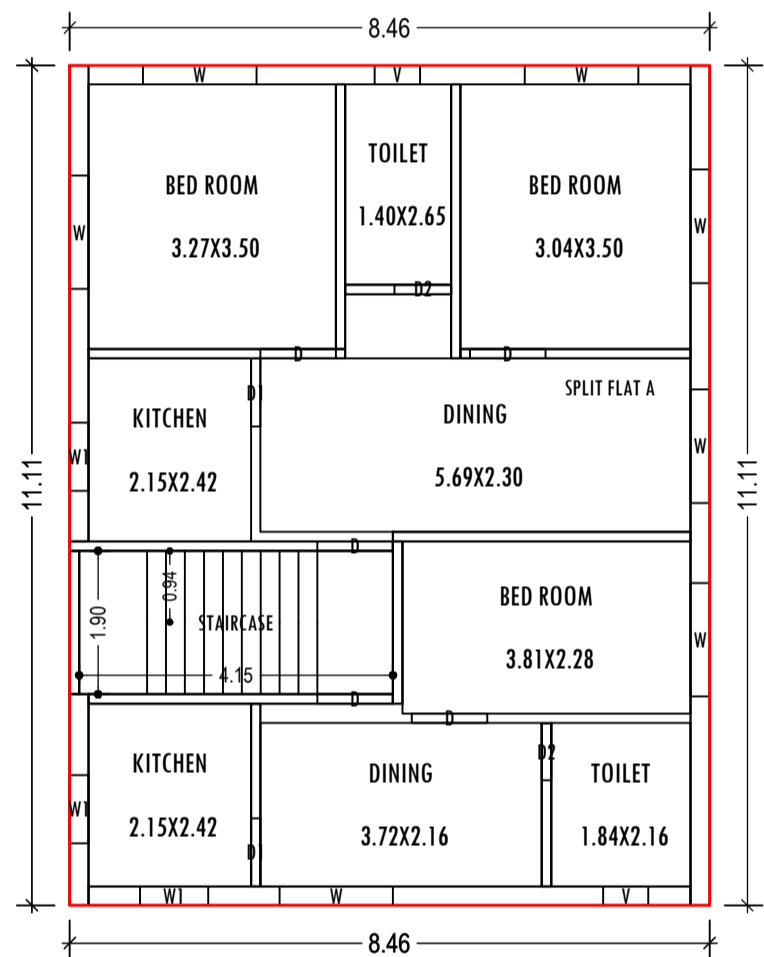

TYPICAL - 1, 2 FLOOR PLAN
(Proposed)
(SCALE 1:100)

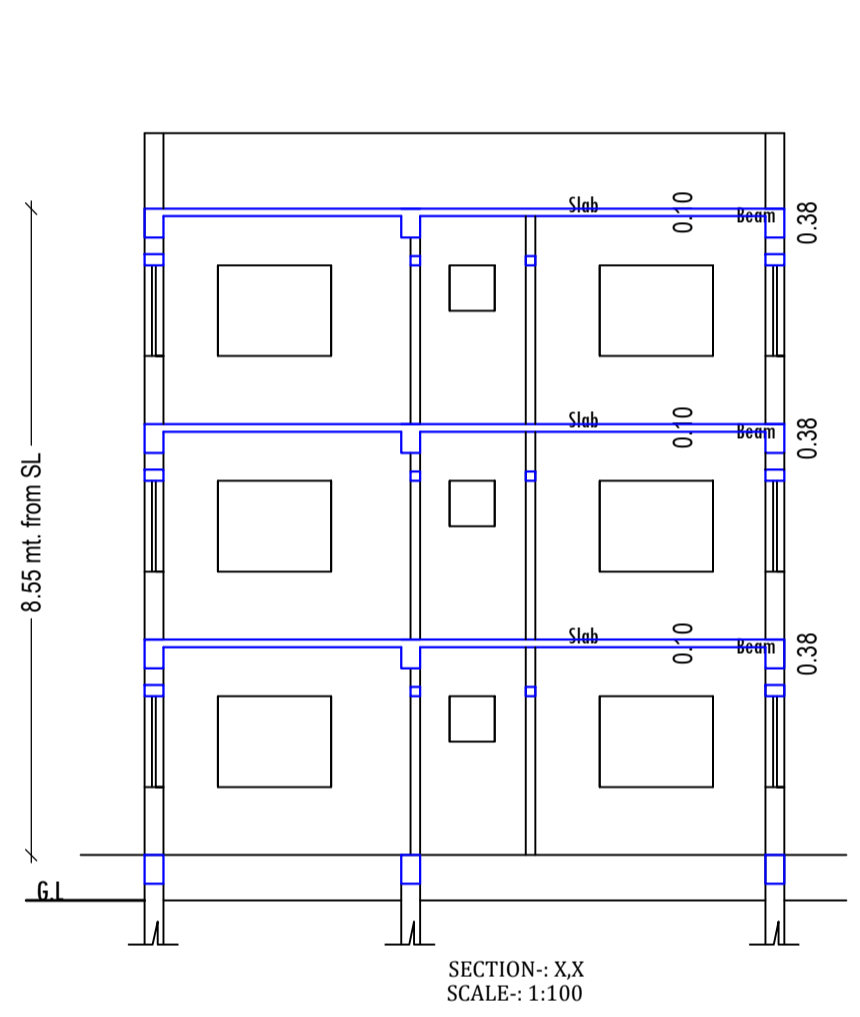

SECTION - XX
SCALE: 1:100

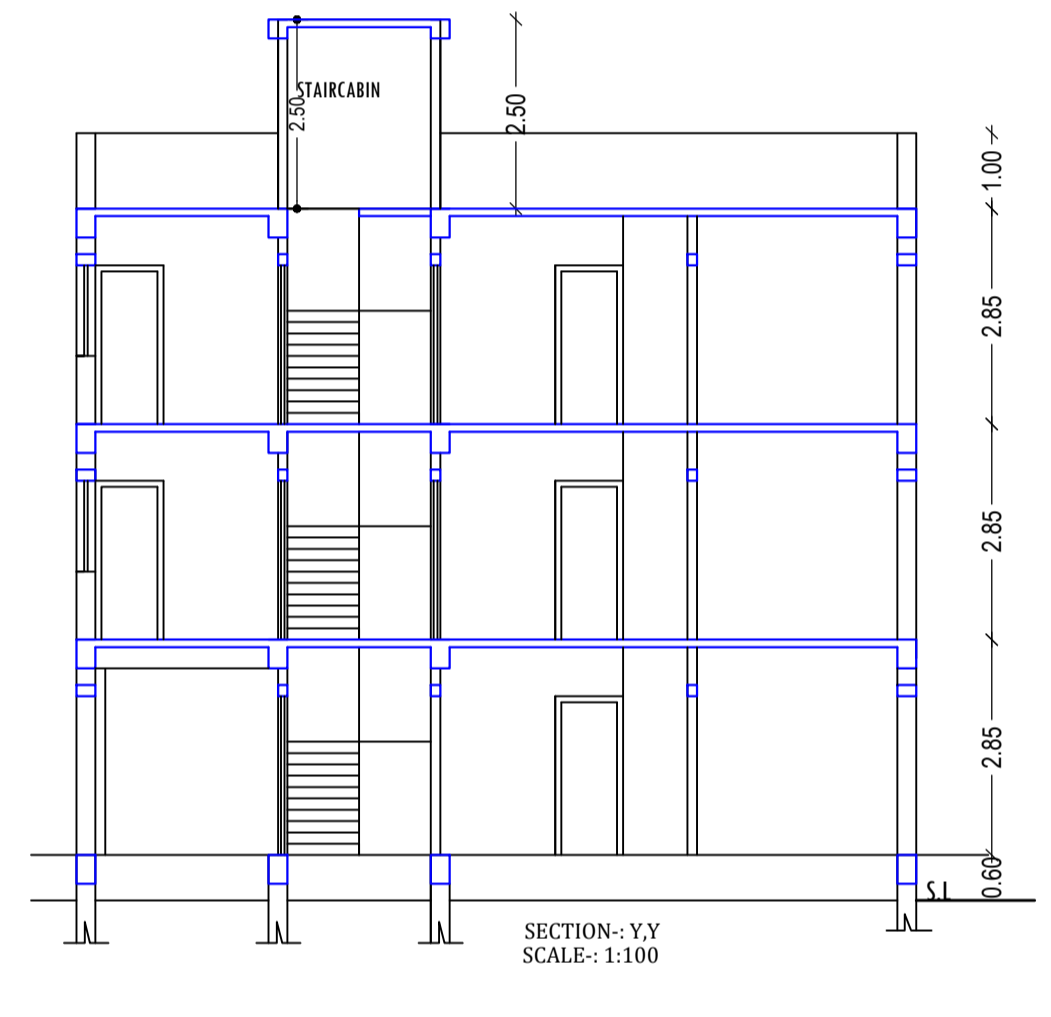

SECTION - YY
SCALE: 1:100

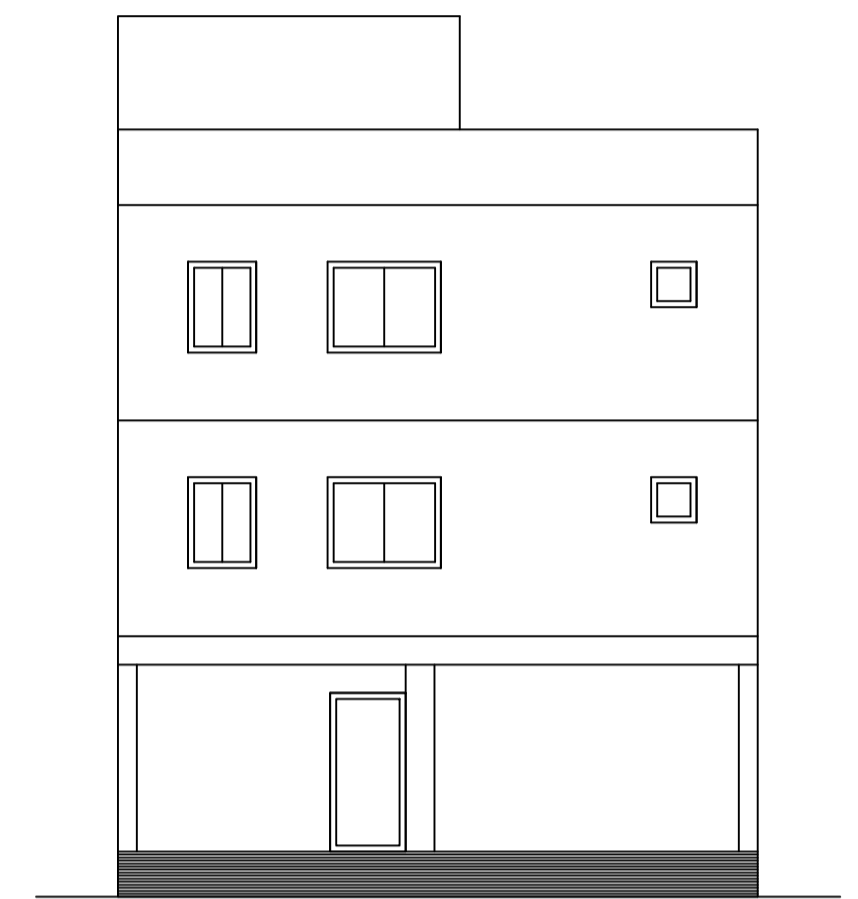
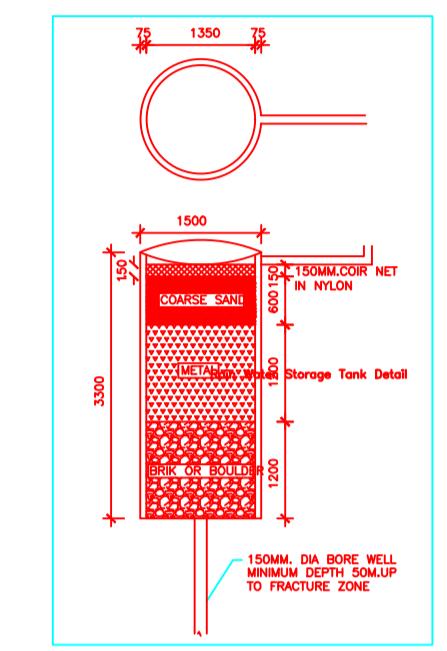

FRONT ELEVATION
SCALE: 1:100

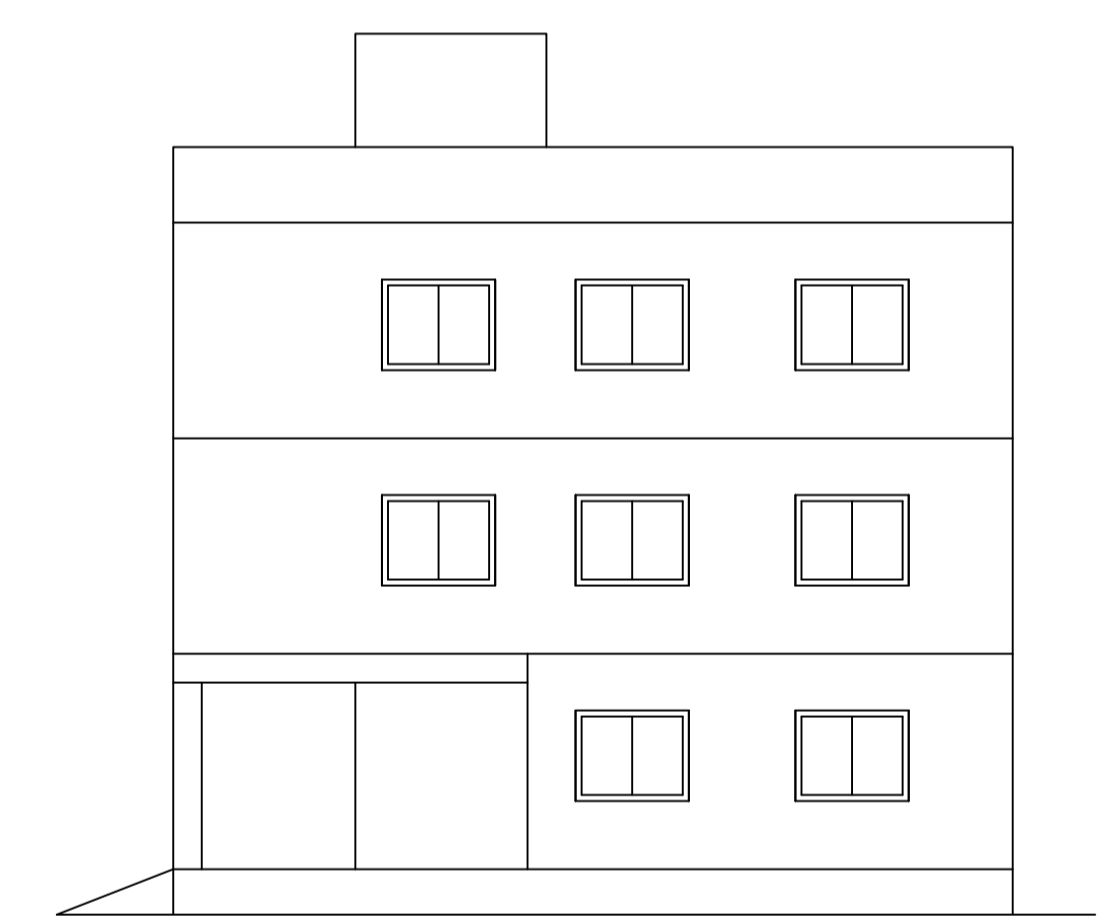

SIDE ELEVATION
SCALE: 1:100

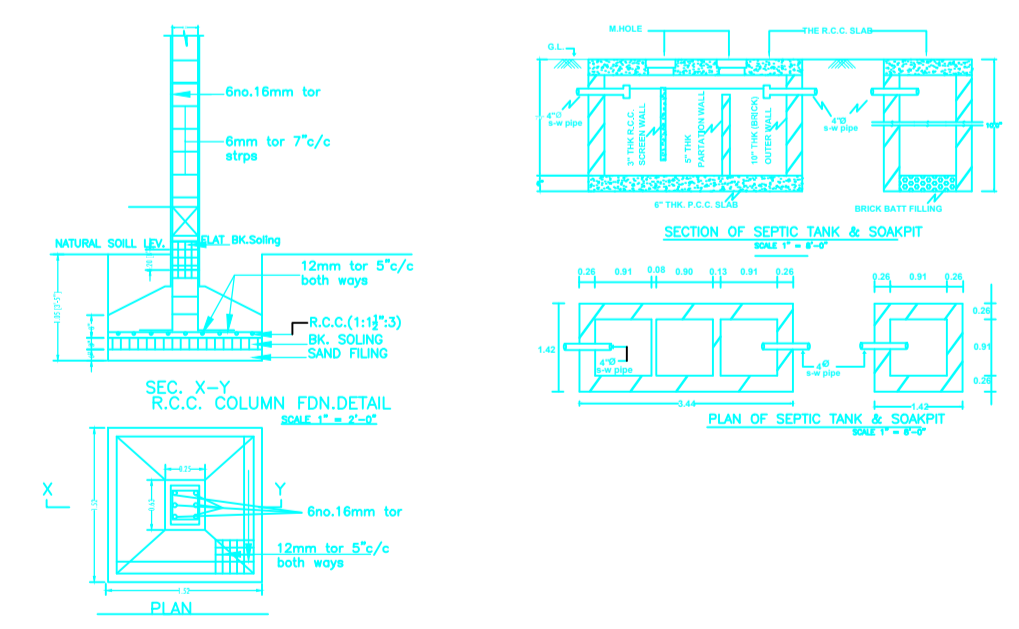

Building :AA (SRI SANJO YADAV)

Floor Name	Total Built Up Area (Sq.mt.)	Deductions (Area in Sq.mt.)		Proposed FAR Area (Sq.mt.)	Total FAR Area (Sq.mt.)	Total Consumed Additional FAR Area (Sq.mt.)	Trmt (No.)
		Parking	Resi.				
Ground Floor	94.01	30.78	63.23	63.23	63.23	63.23	01
First Floor	94.01	0.00	94.01	94.01	94.01	94.01	00
Second Floor	94.01	0.00	94.01	94.01	94.01	94.01	00
Terrace Floor	0.00	0.00	0.00	0.00	0.00	0.00	00
Total :	282.03	30.78	251.25	251.25	251.25	251.25	01
Total Number of Same Buildings	1						
Total :	282.03	30.78	251.25	251.25	251.25	251.25	01

SCHEDULE OF DOOR:

BUILDING NAME	NAME	LENGTH	HEIGHT	NOS
AA (SRI SANJO YADAV)	D2	0.75	2.10	05
AA (SRI SANJO YADAV)	D1	0.90	2.10	05
AA (SRI SANJO YADAV)	D	1.00	2.10	09

SCHEDULE OF WINDOW/VENTILATION:

BUILDING NAME	NAME	LENGTH	HEIGHT	NOS
AA (SRI SANJO YADAV)	V	0.60	0.60	05
AA (SRI SANJO YADAV)	W1	0.90	1.20	07
AA (SRI SANJO YADAV)	W	1.50	1.20	19

UnitBUA Table for Building :AA (SRI SANJO YADAV)

FLOOR	Name	UnitBUA Type	UnitBUA Area	Carpet Area	No. of Rooms	No. of Tenement
GROUND FLOOR PLAN	SPLIT FLAT A	FLAT	199.79	191.92	5	1
AA (SRI SANJO YADAV)	SPLIT FLAT A	FLAT	0.00	0.00	9	0
Total:	-	-	199.79	191.92	23	1

LTP NAME AND SIGNATURE	STRUCTURAL ENG'S NAME AND SIGNATURE	BUILDER NAME AND SIGNATURE	DIGITAL SIGNATURE
MD SHOAIB ALAM JNP/ENG/001/2017			

Proposal Basic Information

Proposal File No.	JNP/EP/0056/W07/2023
Owner Name	SRI SANUJ YADAV
Khata No	01
Plot No	147
Village Name	Jhalpo
Use	Residential
SubUse	Bungalow/ Dwelling / Non Apartment

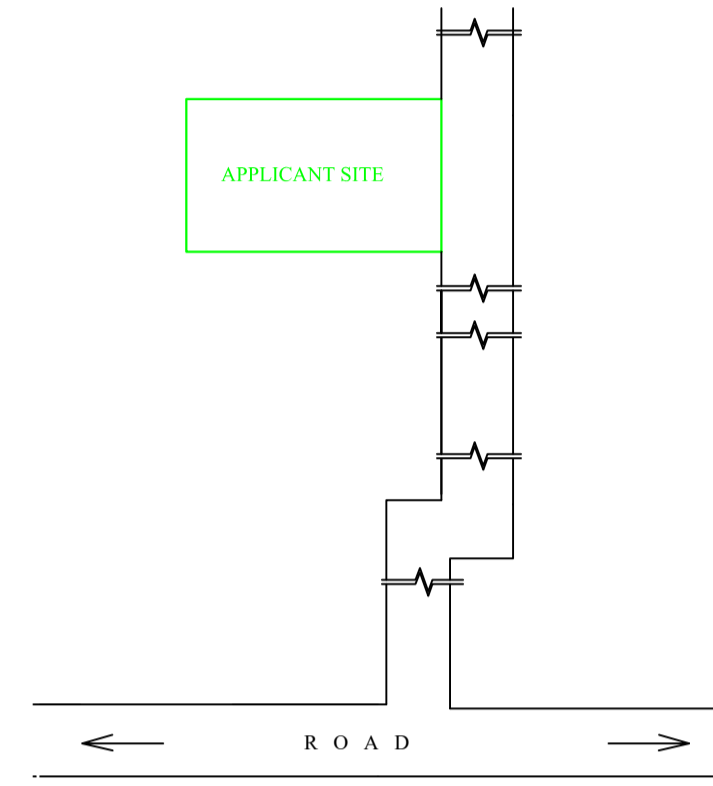

KEY PLAN
NOT TO SCALE

LTP NAME AND SIGNATURE	STRUCTURAL ENG'S NAME AND SIGNATURE	BUILDER NAME AND SIGNATURE	DIGITAL SIGNATURE
MD. SHOAIB ALAM JNP/ENG/0001/2017			