

FAR & Tenement Details (Table 4c-1)

Building	No. of Same Bldg	Total Built Up Area (Sq.mt.)	Deductions (Area in Sq.mt.)		Proposed FAR Area (Sq.mt.)	Total FAR Area (Sq.mt.)	Total Consumed Additional FAR Area (Sq.mt.)	Trmt (No.)
			Archi.Proj.	Resi.				
AA (SMT INDU DEVI)	1	376.47	22.53		353.94	353.94		01
Grand Total :	1	376.47	22.53		353.94	353.94		01

Proposal Basic Information

Proposal File No.	JNP/IBP/0058/W07/2023
Owner Name	SMT INDU DEVI
Khata No	15
Plot No	74
Village Name	Jhalpo
Use	Residential
SubUse	Bungalow/ Dwelling / Non Apartment

AREA STATEMENT	VERSION NO. : 1.0.66	
JHUMRITILAIYA NAGAR	VERSION DATE: 16/10/2020	
PARISHAD		
PROJECT DETAIL:		
Region: JHARKHAND URBAN LOCAL BODIES	Plot Use: Residential	
District: KODERMA	Plot SubUse: Bungalow/ Dwelling / Non Apartment	
Authority: JHUMRITILAIYA NAGAR PARISHAD	PlotNearbyReligiousStructure: NA	
Inward No: JNP/IBP/0058/W07/2023	Plot/SubPlot No: 74	
Application Type: General Proposal	North: Road Width - 3.66M WIDE ROAD	
Project Type: Building Permission	South: Plot No. - NEZ VENDOR	
Nature of Development: New	East: Road Width - 3.66M WIDE ROAD	
Location of Development Area: Old Area	West: Plot No. - NEZ VENDOR	
AREA DETAILS:	SQ.MT.	
AREA OF PLOT (Minimum)	(A)	321.33
NET AREA OF PLOT(Gross Plot Area - Deduction from Gross Plot area)	(A-Deductions)	321.33
Deduction for Balance Plot Area(from Gross Plot Area)		
Common Plot		33.23
BALANCE AREA OF PLOT(Net Plot Area - Recreational/Amenity space)	(A-Deductions)	288.10
PLOT AREA FOR COVERAGE(Net Plot Area)	(A-Deductions)	321.33
Plot Area for FAR (Net Plot Area + RoadWidening Area)	(A-Deductions)	321.33
COVERAGE CHECK		
Permissible Coverage area (60.00 %)		192.80
Proposed Coverage Area (51.57 %)		165.71
Total Prop. Coverage Area (51.57 %)		165.71
Balance coverage area (8.43 %)		27.09
FAR CHECK		
Perm. FAR Area (1.500)		481.99
Total Perm. FAR area		481.99
Residential FAR		353.94
Proposed FAR Area		353.94
Total Proposed FAR Area		353.94
Consumed FAR (Factor)		1.10
Balance FAR Area		128.05
BUILT UP AREA CHECK		
Total Proposed BuiltUp Area		376.47
ARCHITECT (Regd)		MD SHOAB ALAM
ENGINEER (Regd)		
SUPERVISOR (Regd)		
OWNER (Regd)		SMT INDU DEVI
DEVELOPMENT AUTHORITY		LOCAL BODY

COLOR INDEX	
PLOT BOUNDARY	
ABUTTING ROAD	
PROPOSED CONSTRUCTION	
COMMON PLOT	
ROAD WIDENING AREA	
EXISTING (To be retained)	
EXISTING (To be demolished)	

Buildingwise Floor FAR Details

Floor Name	Building Name AA (SMT INDU DEVI)		Total	
	Proposed Built Up Area (Sq.mt.)	Proposed FAR Area (Sq.mt.)	Total Proposed Built Up Area (Sq.mt.)	Total FAR Area (Sq.mt.)
Ground Floor	188.24	165.71	188.24	165.71
First Floor	188.23	188.23	188.23	188.23
Terrace Floor	0.00	0.00	0.00	0.00
Total :	376.47	353.94	376.47	353.94

Building USE/SUBUSE Details

Building Name	Building Use	Building SubUse	Building Structure
AA (SMT INDU DEVI)	Residential	Bungalow/ Dwelling / Non Apartment	Non-Highrise

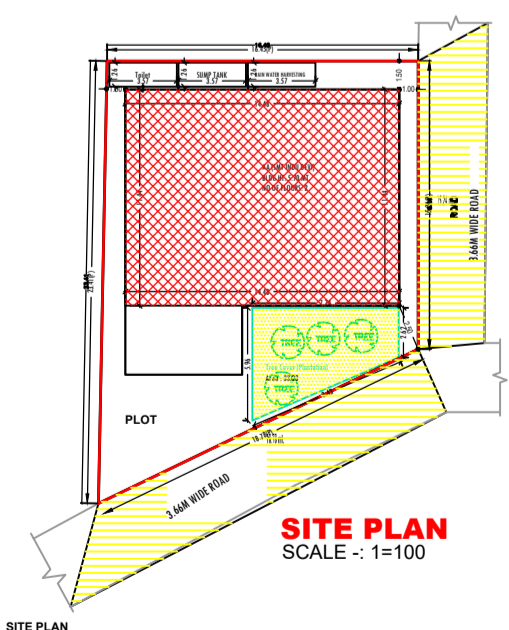

(Scale - 1:400)

LTP NAME AND SIGNATURE	STRUCTURAL ENG'S NAME AND SIGNATURE	BUILDER NAME AND SIGNATURE	DIGITAL SIGNATURE
MD SHOAB ALAM JNP/ENG/0001/2017			

Proposal Basic Information

Proposal File No.	JNP/BP/0058/W07/2023
Owner Name	SMT INDU DEVI
Khata No	15
Plot No	74
Village Name	Jhalpo
Use	Residential
SubUse	Bungalow/ Dwelling / Non Apartment

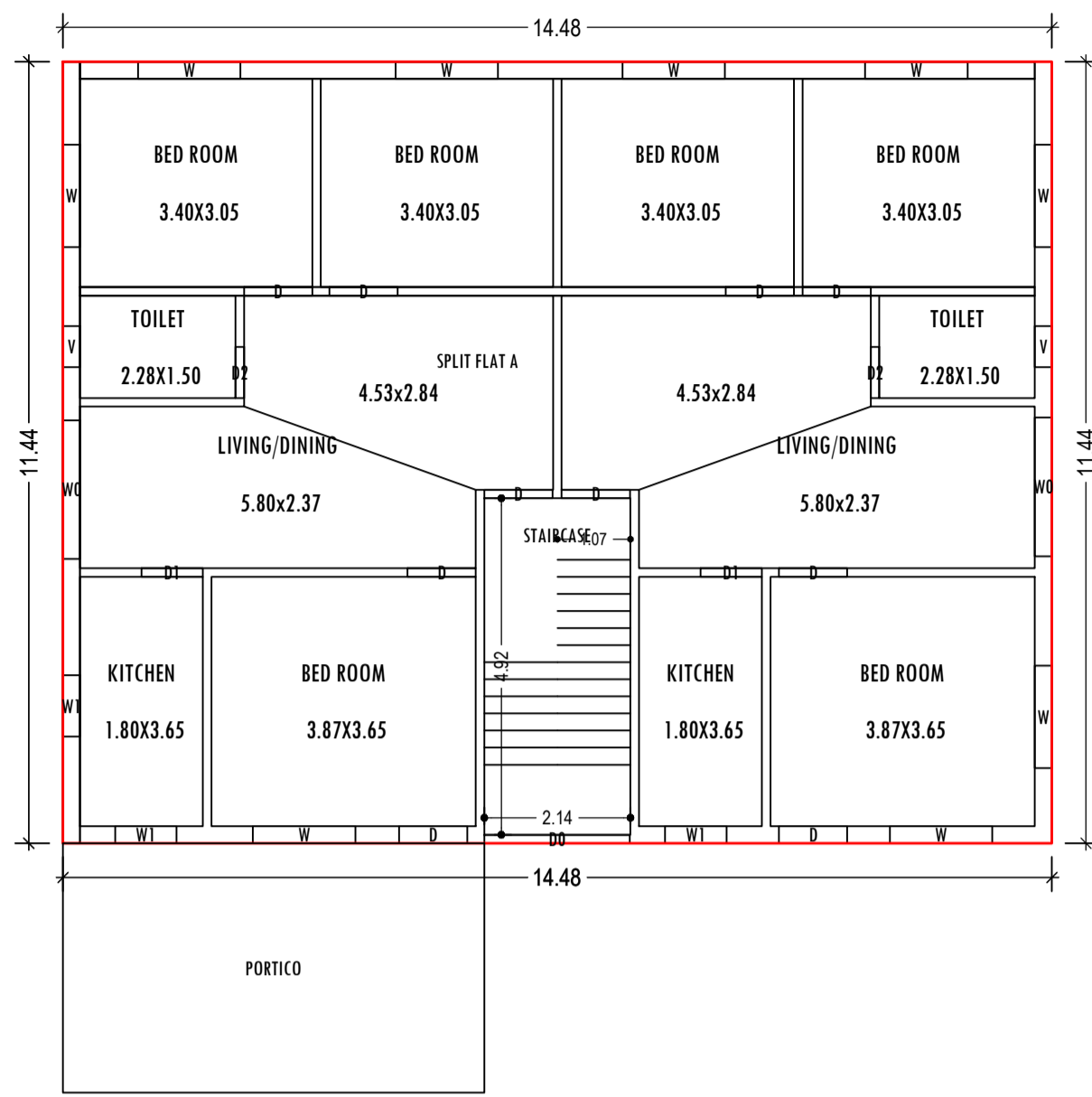

GROUND FLOOR PLAN
(Proposed)
(SCALE 1:100)

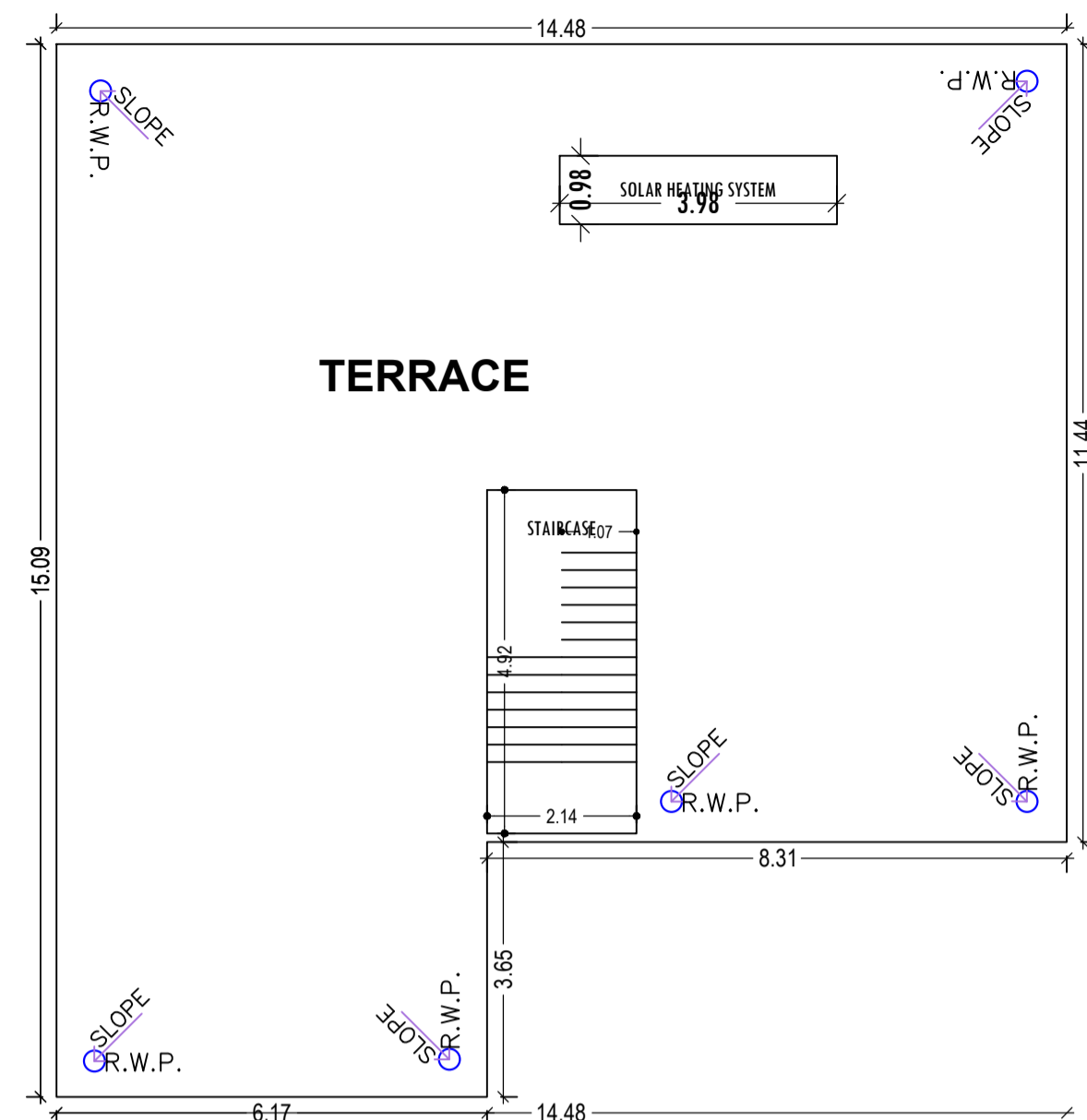

TERRACE FLOOR PLAN
(SCALE 1:100)

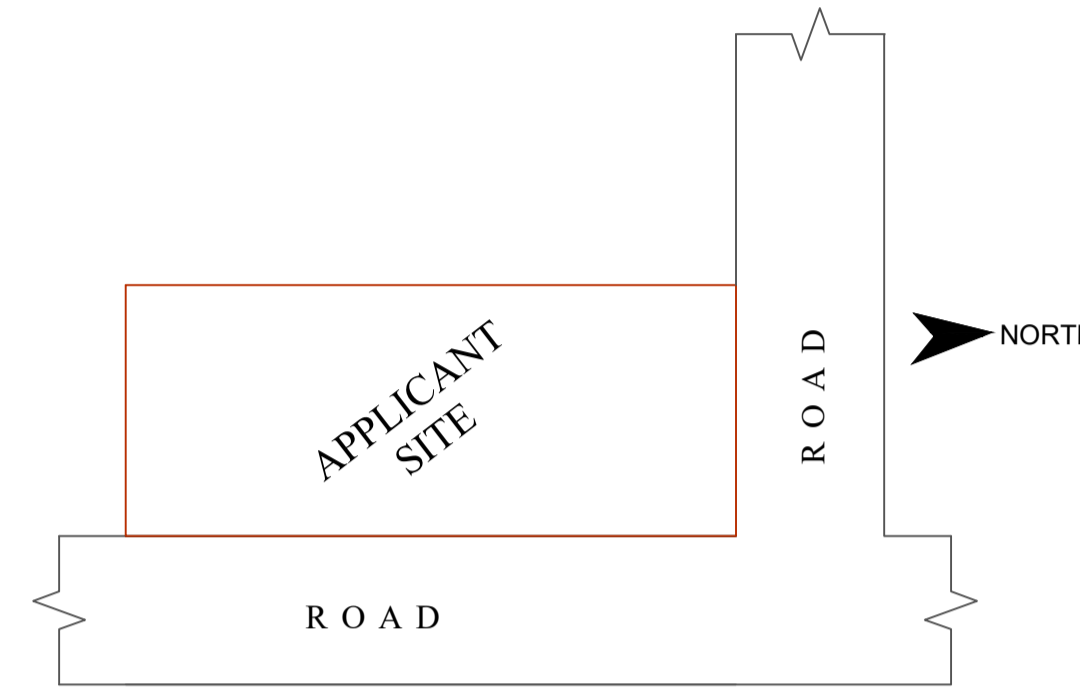

SITE KEY PLAN
NOT TO SCALE

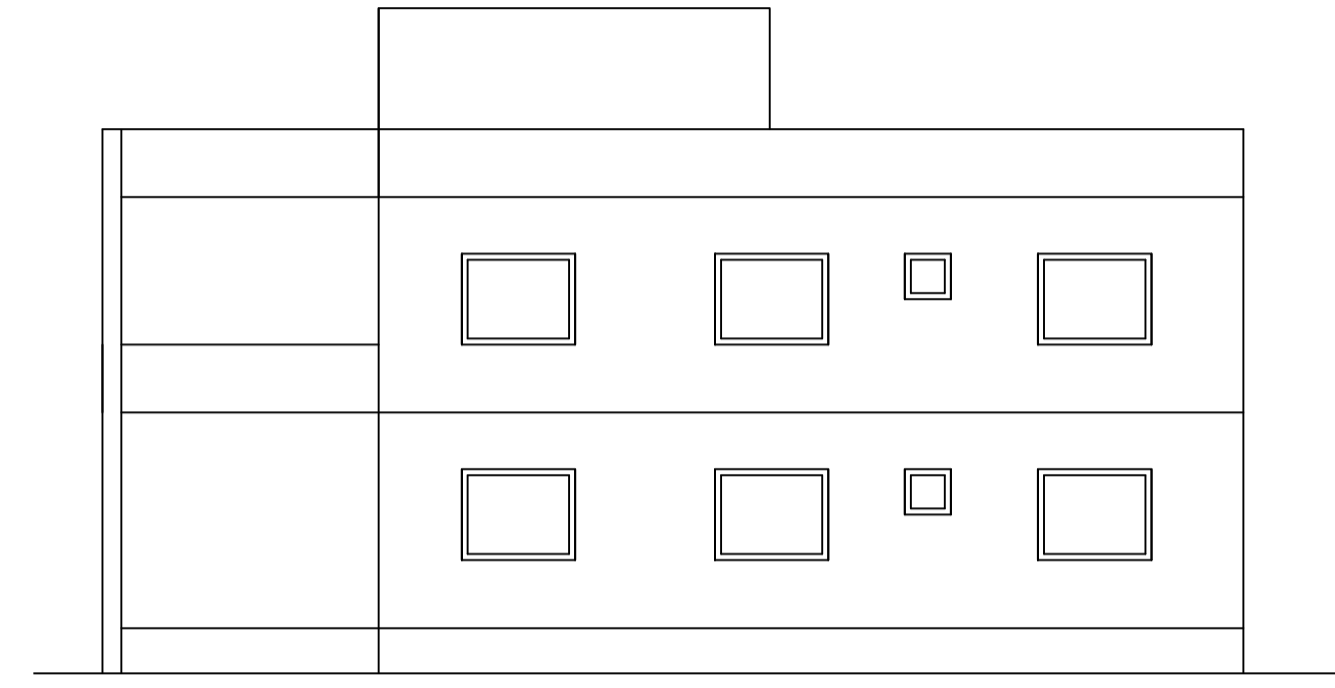

SIDE ELEVATION
SCALE - 1:100

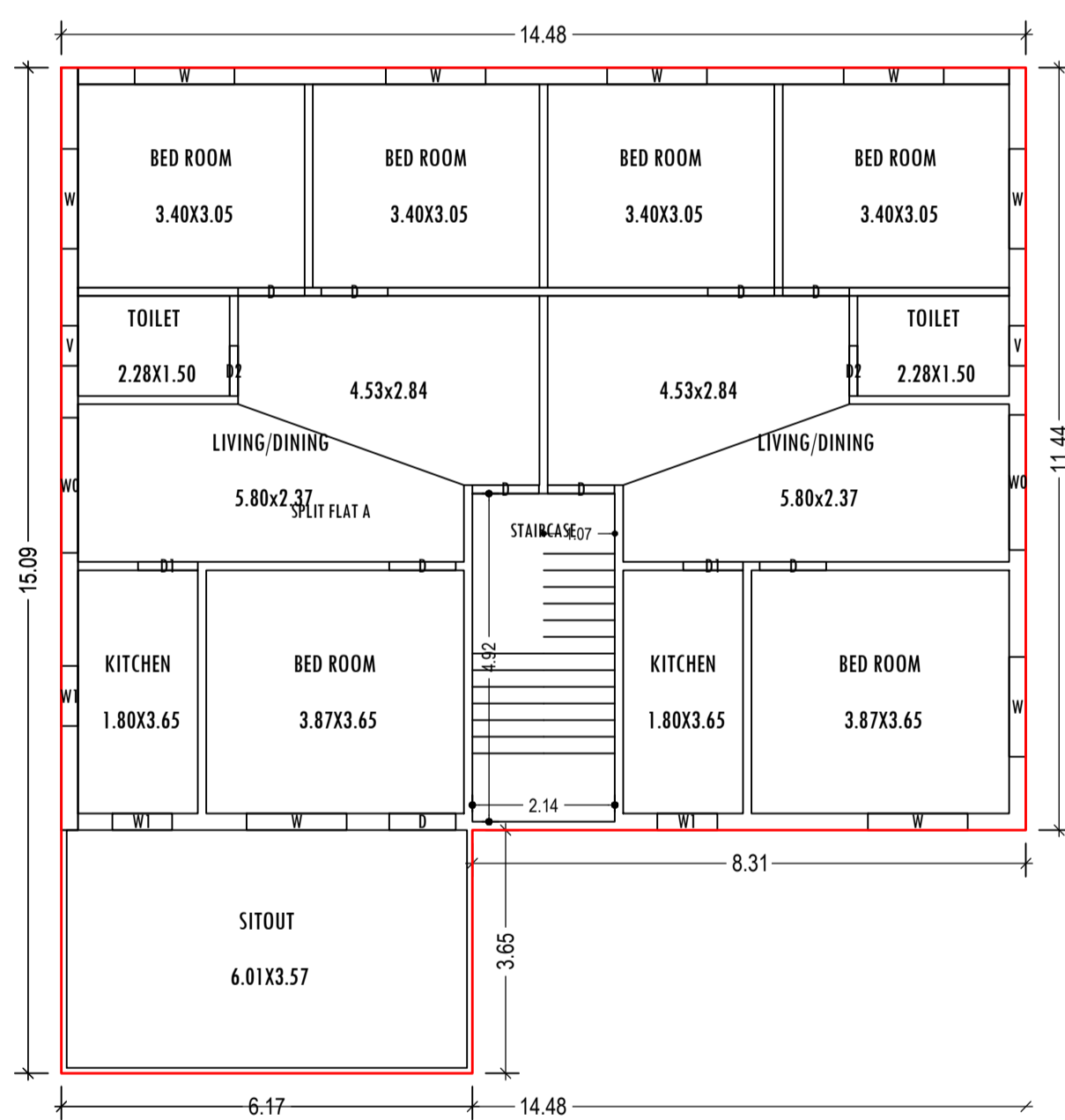
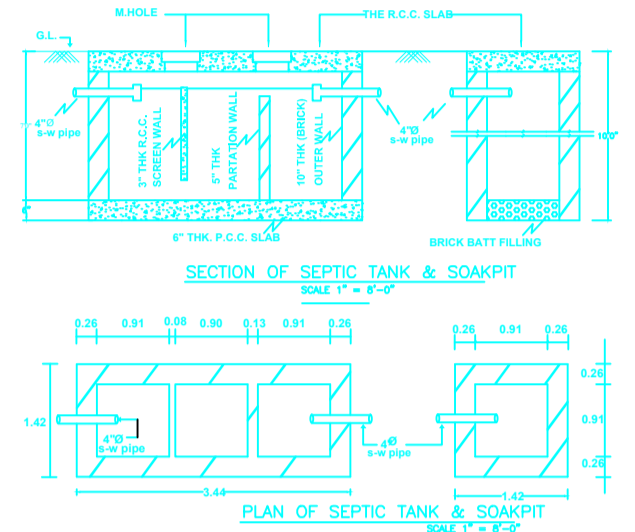

FIRST FLOOR PLAN
(Proposed)
(SCALE 1:100)

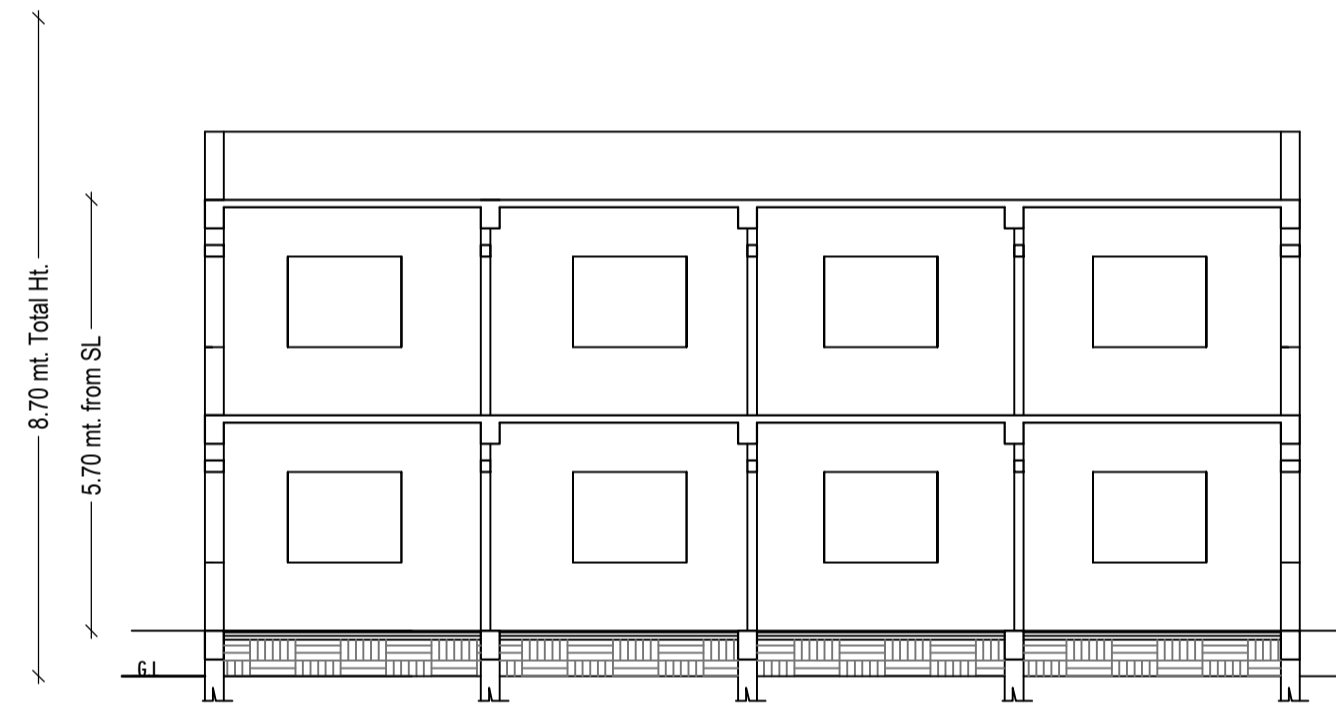

SECTION - A-A'
SCALE - 1:100

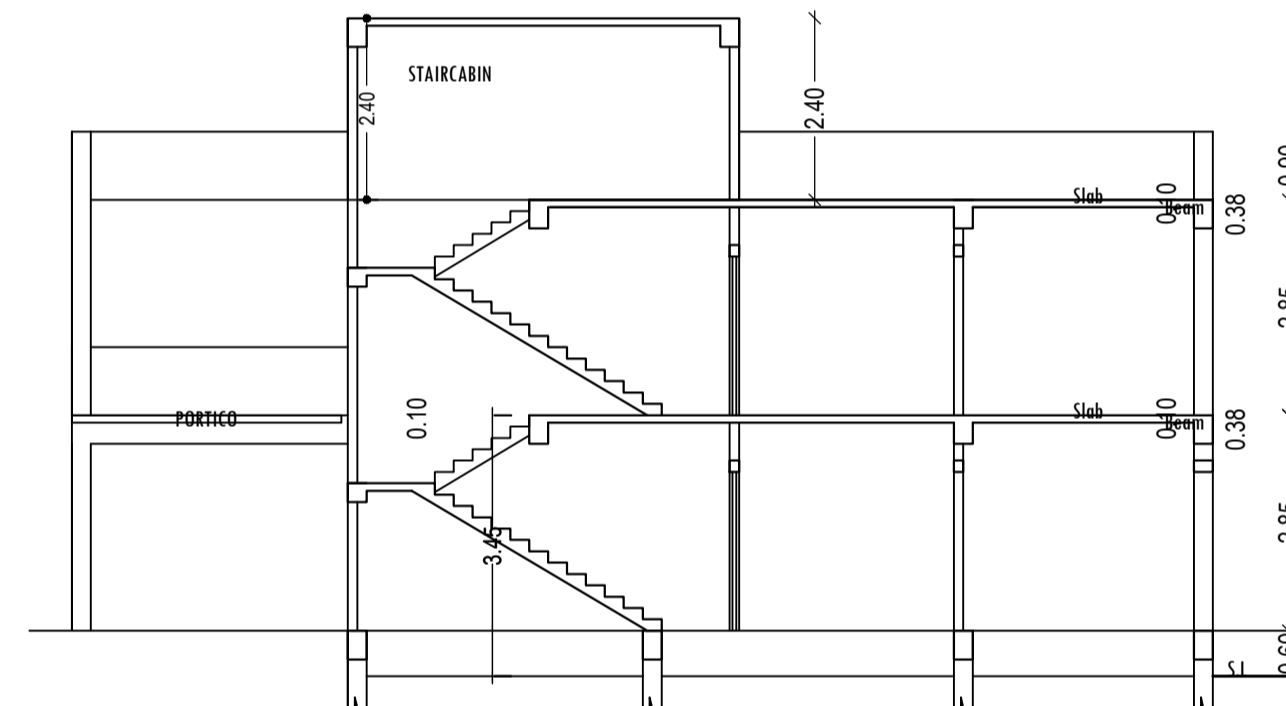

SECTION - B-B'
SCALE - 1:100

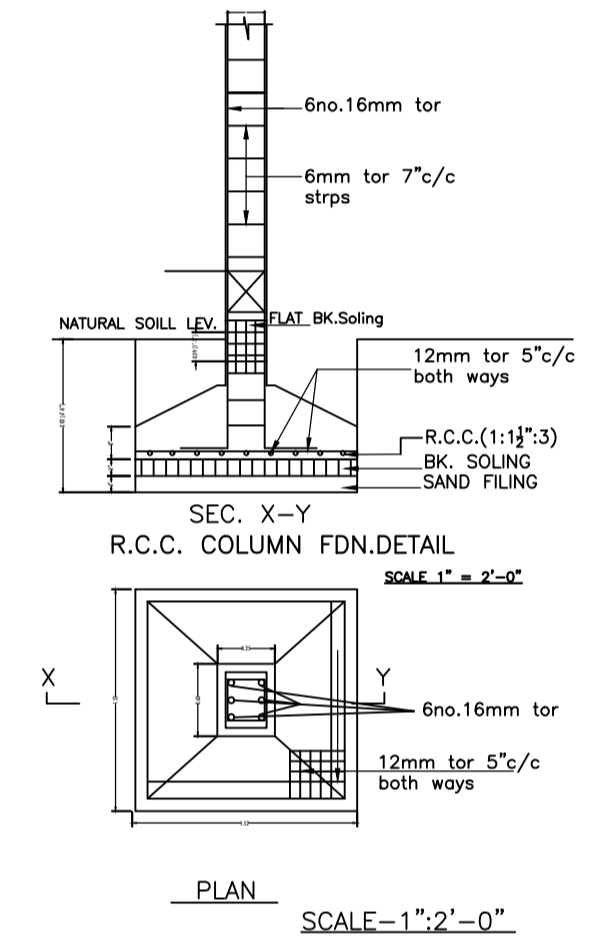

R.C.C. COLUMN FDN. DETAIL
SCALE - 1:2'-0"



FRONT ELEVATION
SCALE - 1:100

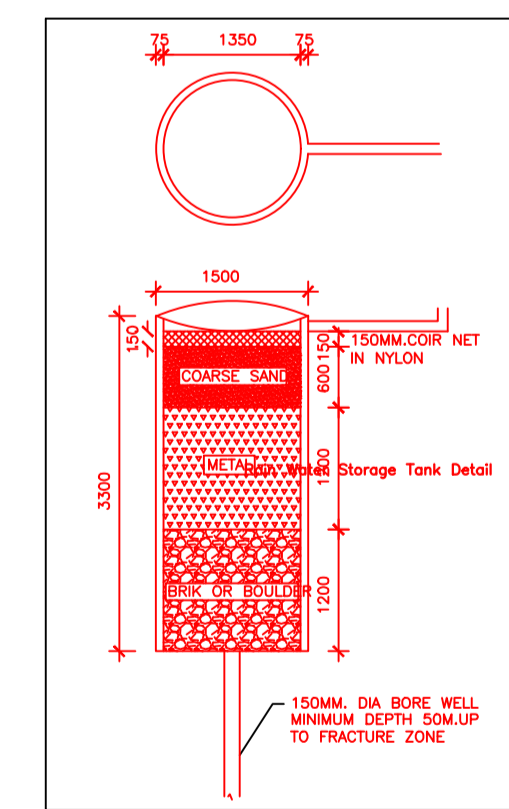

Building -AA (SMT INDU DEVI)

Floor Name	Total Built Up Area (Sq.mt.)	Deductions (Area in Sq.mt.)	Proposed FAR Area (Sq.mt.)	Total FAR Area (Sq.mt.)	Total Consumed Additional FAR Area (Sq.mt.)	Trmt (No.)
Ground Floor	188.24	22.53	165.71	165.71	165.71	01
First Floor	188.23	0.00	188.23	188.23	188.23	00
Terrace Floor	0.00	0.00	0.00	0.00	0.00	00
Total :	376.47	22.53	353.94	353.94	353.94	01
Total Number of Same Buildings	1					
Total :	376.47	22.53	353.94	353.94	353.94	01

SCHEDULE OF DOOR:

BUILDING NAME	NAME	LENGTH	HEIGHT	NOS
AA (SMT INDU DEVI)	D2	0.75	2.10	04
AA (SMT INDU DEVI)	D1	0.90	2.10	04
AA (SMT INDU DEVI)	D	1.00	2.10	19

SCHEDULE OF WINDOW/VENTILATION:

BUILDING NAME	NAME	LENGTH	HEIGHT	NOS
AA (SMT INDU DEVI)	V	0.60	0.60	04
AA (SMT INDU DEVI)	W1	0.90	1.20	06
AA (SMT INDU DEVI)	W	1.50	1.20	18
AA (SMT INDU DEVI)	W0	2.03	1.20	04

UnitBUA Table for Building -AA (SMT INDU DEVI)

FLOOR	Name	UnitBUA Type	UnitBUA Area	Carpet Area	No. of Rooms	No. of Tenement
GROUND FLOOR PLAN	SPLIT FLAT A	FLAT	305.35	301.86	12	1
FIRST FLOOR PLAN	SPLIT FLAT A	FLAT	0.00	0.00	13	0
Total:	-	-	305.35	301.86	25	1

LTP NAME AND SIGNATURE	STRUCTURAL ENG'S NAME AND SIGNATURE	BUILDER NAME AND SIGNATURE	DIGITAL SIGNATURE
MD SHOAB ALAM JNP/ENG/001/2017			