

GROUND FLOOR PLAN (Proposed) (SCALE 1:100)

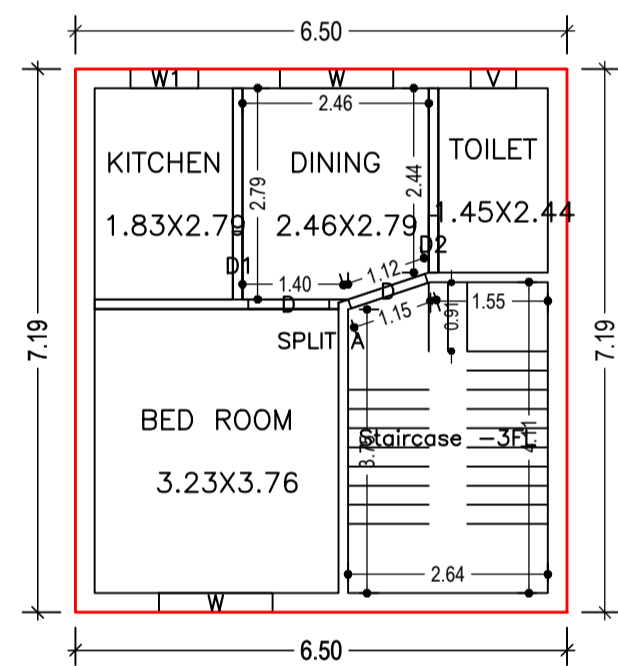

FIRST FLOOR PLAN (Proposed) (SCALE 1:100)

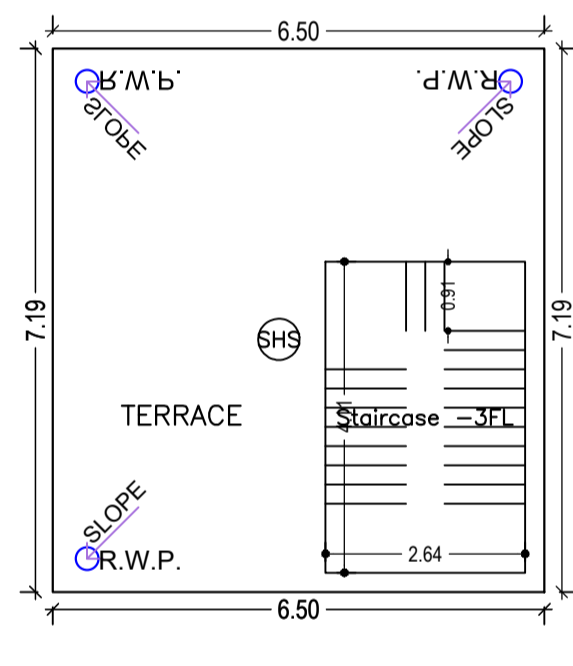

TERRACE FLOOR PLAN (SCALE 1:100)

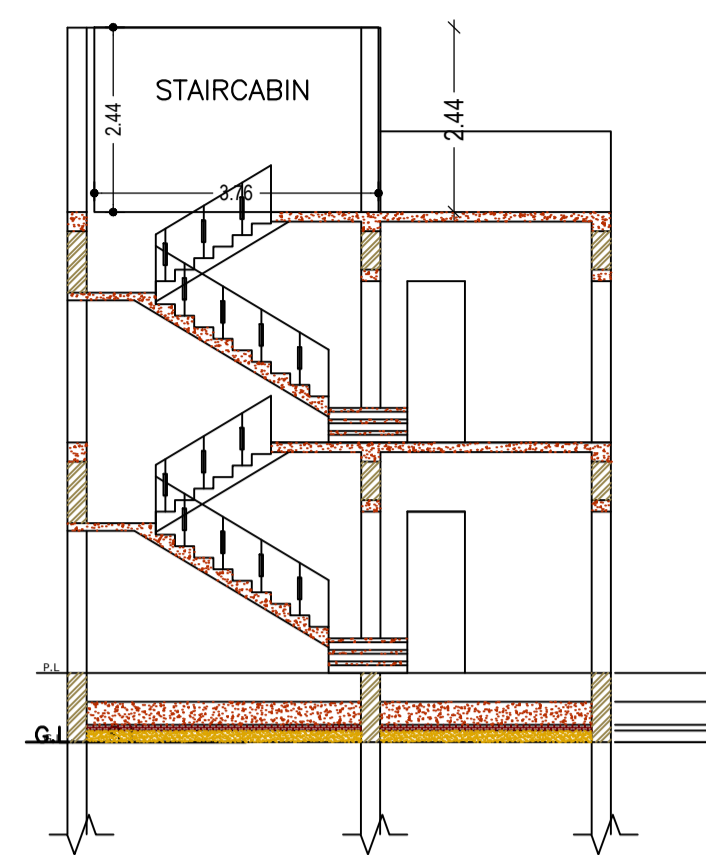

CROSS SECTION (A)

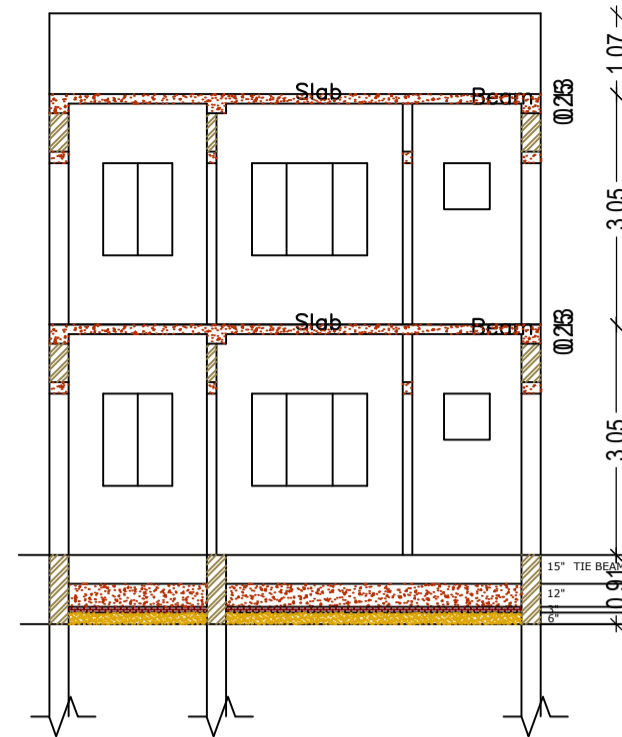

CROSS SECTION (B)

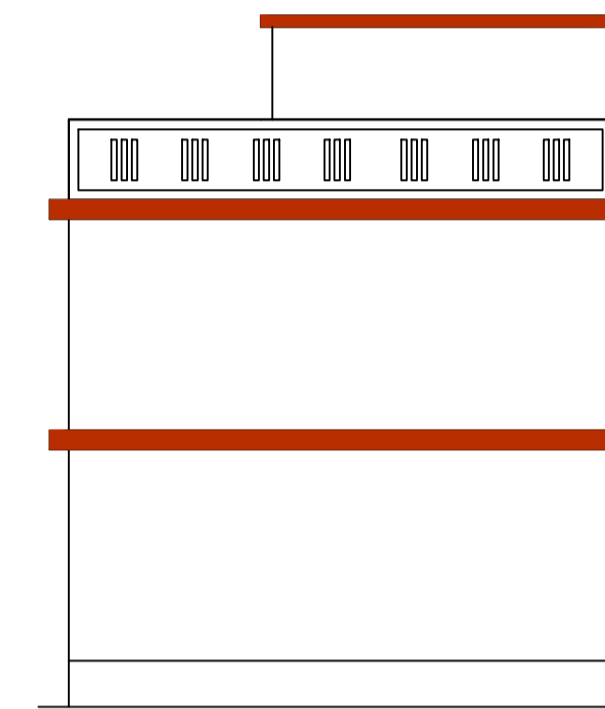

CROSS ELEVATION

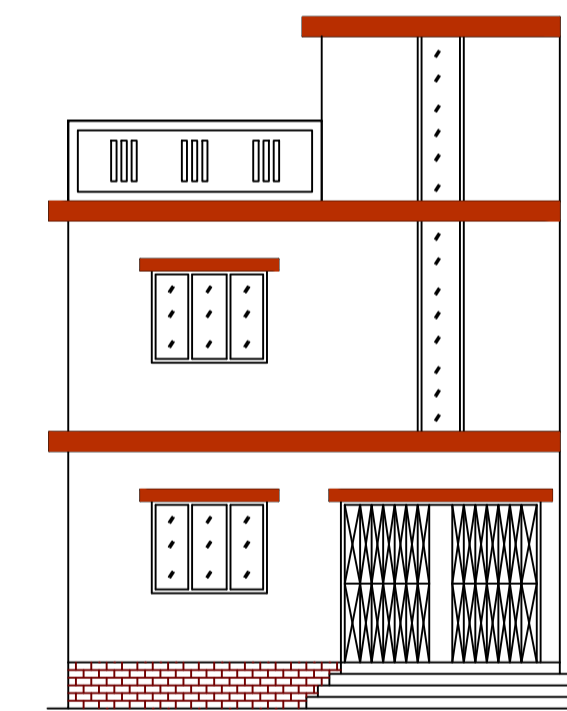

FRONT ELEVATION

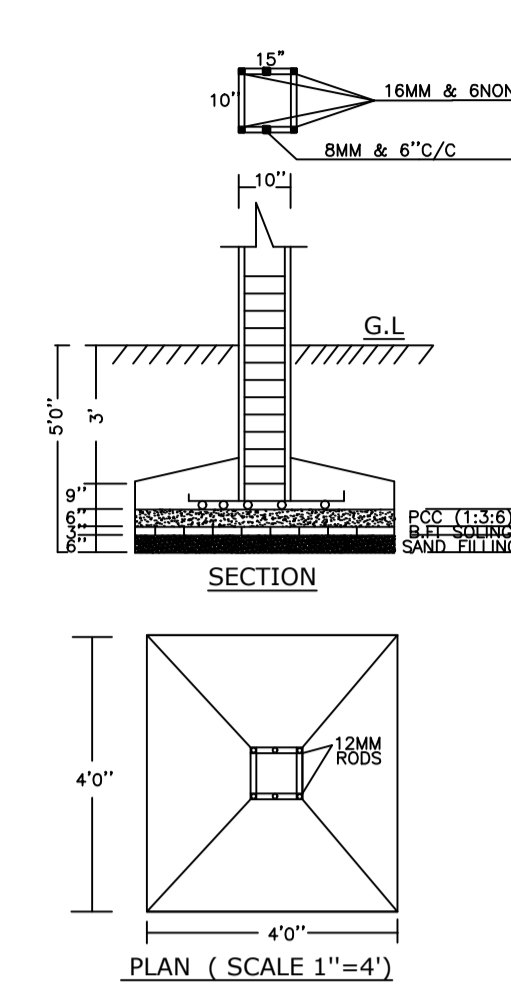

PLAN (SCALE 1"=4')

AREA STATEMENT		VERSION NO.: 1.0.66
LOCAL BODIES		VERSION DATE: 16/10/2020
PROJECT DETAIL:		
Region: JHARKHAND URBAN	Plot Use: Residential	
District: KODERMA	Plot SubUse: Bungalow/ Dwelling / Non Apartment	
Authority: JHUMRITILAIYA NAGAR PARISHAD	PlotNearby/ReligiousStructure: NA	
Inward No: JNP/BP/0066/W14/2023	PlotSubPlot No: 7061	
Application Type: General Proposal	North: Plot No. - NU VENDEE	
Project Type: Building Permission	South: Road Width - 3.96	
Nature of Development: New	East: Road Width - 1.52 GALI	
Location of Development Area: Old Area	West: Road Width - 1.52 GALI	
AREA DETAILS:		
AREA OF PLOT (Minimum)	(A)	80.13
NET AREA OF PLOT(Gross Plot Area - Deduction from Gross Plot area)	(A-Deductions)	80.13
Deduction for Balance Plot Area(from Gross Plot Area)		
Common Plot		11.27
Total		11.27
BALANCE AREA OF PLOT(Net Plot Area - Recreational/Amenity space)	(A-Deductions)	68.86
PLOT AREA FOR COVERAGE(Net Plot Area)	(A-Deductions)	80.13
Plot Area for FAR (Net Plot Area + Road Widening Area)	(A-Deductions)	80.13
COVERAGE CHECK		
Permissible Coverage area (70.00 %)		56.09
Proposed Coverage Area (58.33 %)		46.74
Total Prop. Coverage Area (58.33 %)		46.74
Balance coverage area (11.67 %)		9.35
FAR CHECK		
Perm. FAR Area (1.500)		120.19
Total Perm. FAR area		120.19
Residential FAR		93.48
Proposed FAR Area		93.48
Total Proposed FAR Area		93.48
Consumed FAR (Factor)		1.17
Balance FAR Area		26.71
BUILT UP AREA CHECK		
Total Proposed BuiltUp Area		93.48
ARCHITECT (Regd)	KIRAN KUMARI	
ENGINEER (Regd)		
SUPERVISOR (Regd)		
OWNER (Regd)	SMT MALTI DEVI	
DEVELOPMENT AUTHORITY		LOCAL BODY

COLOR INDEX	
PLOT BOUNDARY	Black
ABUTTING ROAD	Green
PROPOSED CONSTRUCTION	Red
COMMON PLOT	Yellow
ROAD WIDENING AREA	Blue
EXISTING (To be retained)	Orange
EXISTING (To be demolished)	Grey

Buildingwise Floor FAR Details

Floor Name	Building Name A (RESIDENTIAL)		Total	
	Proposed Built Up Area (Sq.mt.)	Proposed FAR Area (Sq.mt.)	Total Proposed Built Up Area (Sq.mt.)	Total FAR Area (Sq.mt.)
Ground Floor	46.74	46.74	46.74	46.74
First Floor	46.74	46.74	46.74	46.74
Terrace Floor	0.00	0.00	0.00	0.00
Total :	93.48	93.48	93.48	93.48

Building USE/SUBUSE Details

Building Name	Building Use	Building SubUse	Building Structure
A (RESIDENTIAL)	Residential	Bungalow/ Dwelling / Non Apartment	Non-Highrise

FAR & Tenement Details (Table 4c-1)

Building	No. of Same Bldg	Total Built Up Area (Sq.mt.)	Proposed FAR Area (Sq.mt.)	Total FAR Area (Sq.mt.)	Total Consumed Additional FAR Area (Sq.mt.)	Tnmt (No.)
A (RESIDENTIAL)	1	93.48	93.48	93.48	93.48	01
Grand Total :	1	93.48	93.48	93.48	93.48	01

Building :A (RESIDENTIAL)

Floor Name	Total Built Up Area (Sq.mt.)	Proposed FAR Area (Sq.mt.)	Total FAR Area (Sq.mt.)	Total Consumed Additional FAR Area (Sq.mt.)	Tnmt (No.)
Ground Floor	46.74	46.74	46.74	46.74	01
First Floor	46.74	46.74	46.74	46.74	00
Terrace Floor	0.00	0.00	0.00	0.00	00
Total :	93.48	93.48	93.48	93.48	01
Total Number of Same Buildings	1				
Total :	93.48	93.48	93.48	93.48	01

SCHEDULE OF DOOR:

BUILDING NAME	NAME	LENGTH	HEIGHT	NOS
A (RESIDENTIAL)	D2	0.75	2.10	02
A (RESIDENTIAL)	D1	0.90	2.10	02
A (RESIDENTIAL)	D	1.07	2.10	04

SCHEDULE OF WINDOW/VENTILATION:

BUILDING NAME	NAME	LENGTH	HEIGHT	NOS
A (RESIDENTIAL)	V	0.60	0.90	02
A (RESIDENTIAL)	W1	0.90	1.20	02
A (RESIDENTIAL)	W	1.50	1.20	04

UnitBUA Table for Building :A (RESIDENTIAL)

FLOOR	Name	UnitBUA Type	UnitBUA Area	Carpet Area	No. of Rooms	No. of Tenement
GROUND FLOOR PLAN	SPLIT A	FLAT	57.07	54.92	4	1
FIRST FLOOR PLAN	SPLIT A	FLAT	0.00	0.00	4	0
Total:	-	-	57.07	54.92	8	1

LOCATION PLAN (SCALE -1"=32')

