

Proposal Basic Information	
Proposal File No.	JNP/IBP/0125/W02/2023
Owner Name	SMT MANJU DEVI
Khata No	1025
Plot No	3795
Village Name	Tilaiya
Use	Residential
SubUse	Bungalow/ Dwelling / Non Apartment

AREA STATEMENT		VERSION NO.:	1.0.69
JHUMRITILAIYA NAGAR PARISHAD		VERSION DATE: 16/10/2020	
PROJECT DETAIL:			
Region: JHARKHAND URBAN LOCAL BODIES	Plot Use: Residential		
District: KODERMA	Plot SubUse: Bungalow/ Dwelling / Non Apartment		
Authority: JHUMRITILAIYA NAGAR PARISHAD	PlotNearbyReligiousStructure: NA		
Inward No: JNP/IBP/0125/W02/2023	Plot/SubPlot No: 3795		
Application Type: General Proposal	North: Road Width - 4.27		
Project Type: Building Permission	South: Plot No. - PLOT NO 3802 AND 3813		
Nature of Development: New	East: Plot No. - LAND OF SUPER SMELTER		
Location of Development Area: Old Area	West: Plot No. - LAND OF PRITI ARADHNA		
AREA DETAILS:		SQ.MT.	
AREA OF PLOT (Minimum)	(A)	68.93	
NET AREA OF PLOT(Gross Plot Area - Deduction from Gross Plot area)	(A-Deductions)	68.93	
Deduction for Balance Plot Area(from Gross Plot Area)			
Common Plot		12.37	
Total		12.37	
BALANCE AREA OF PLOT(Net Plot Area - Recreational/Amenity space)	(A-Deductions)	56.56	
PLOT AREA FOR COVERAGE(Net Plot Area)	(A-Deductions)	68.93	
Plot Area for FAR (Net Plot Area + Road/Widening Area)	(A-Deductions)	68.93	
COVERAGE CHECK			
Permissible Coverage area (70.00 %)		48.25	
Proposed Coverage Area (49.60 %)		34.19	
Total Prop. Coverage Area (49.6 %)		34.19	
Balance coverage area (20.40 %)		14.06	
FAR CHECK			
Perm. FAR Area (1.500)		103.40	
Total Perm. FAR area		103.40	
Residential FAR		102.57	
Proposed FAR Area		102.57	
Total Proposed FAR Area		102.57	
Consumed FAR (Factor)		1.49	
Balance FAR Area		0.83	
BUILT UP AREA CHECK			
Total Proposed BuiltUp Area		102.57	
ARCHITECT (Regd)	KIRAN KUMARI		
ENGINEER (Regd)			
SUPERVISOR (Regd)			
OWNER (Regd)	SMT MANJU DEVI		
DEVELOPMENT AUTHORITY		LOCAL BODY	

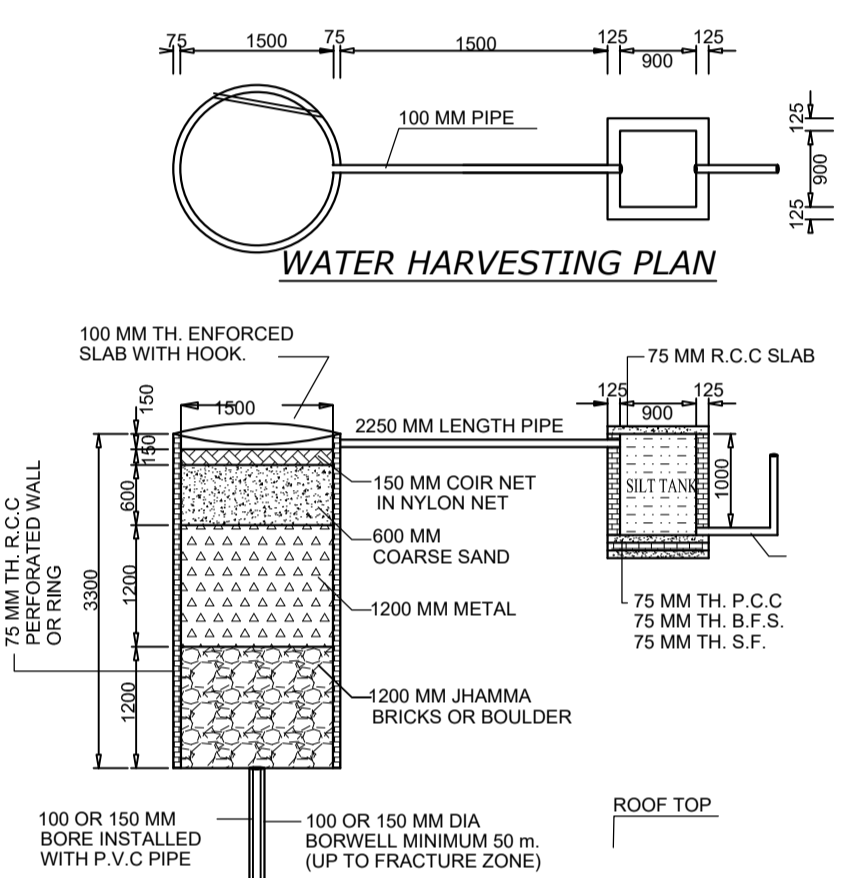
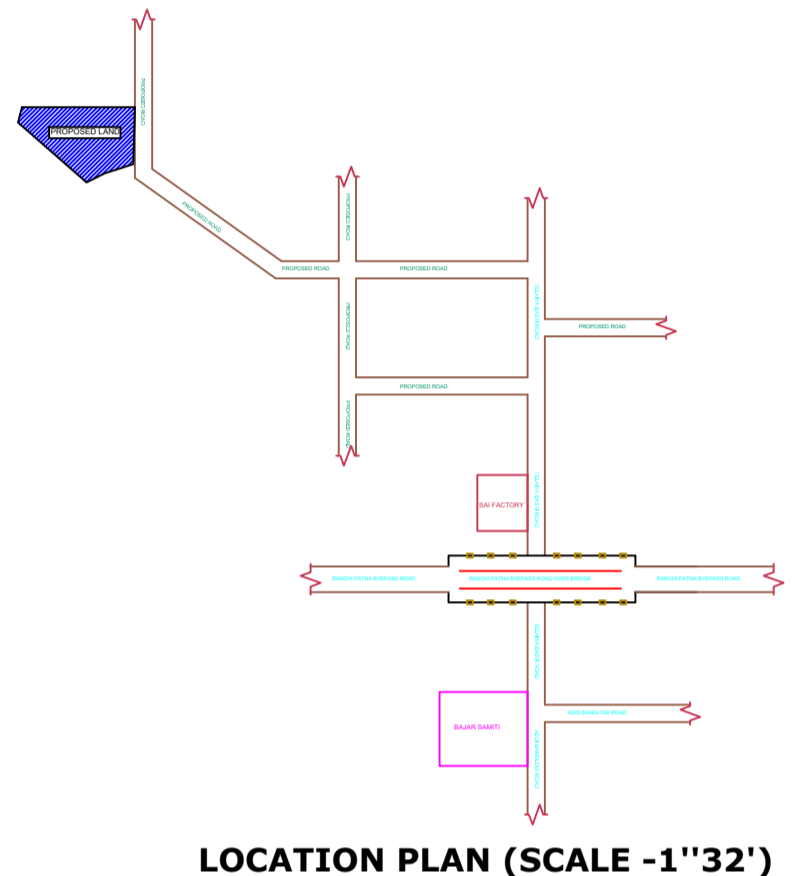
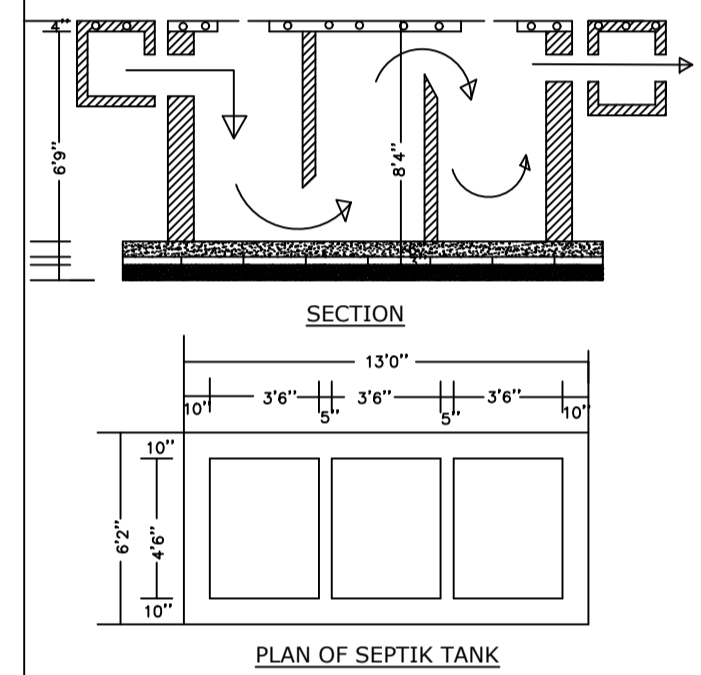

UnitBUA Table for Building :A (RESIDENTIAL)

FLOOR	Name	UnitBUA Type	UnitBUA Area	Carpet Area	No. of Rooms	No. of Tenement
GROUND FLOOR PLAN	SPLIT A	FLAT	57.28	55.51	3	1
FIRST FLOOR PLAN	SPLIT A	FLAT	0.00	0.00	3	0
SECOND FLOOR PLAN	SPLIT A	FLAT	0.00	0.00	3	0
Total:	-	-	57.28	55.51	9	1

SCHEDULE OF DOOR:

BUILDING NAME	NAME	LENGTH	HEIGHT	NOS
A (RESIDENTIAL)	D2	0.75	2.10	03
A (RESIDENTIAL)	D1	0.90	2.10	01
A (RESIDENTIAL)	D	1.05	2.10	02

SCHEDULE OF WINDOW/VENTILATION:

BUILDING NAME	NAME	LENGTH	HEIGHT	NOS
A (RESIDENTIAL)	V	0.60	0.90	03
A (RESIDENTIAL)	W1	0.90	1.20	01
A (RESIDENTIAL)	W	1.50	1.20	06

Building :A (RESIDENTIAL)

Floor Name	Total Built Up Area (Sq.mt.)	Proposed FAR Area (Sq.mt.) Resi.	Total FAR Area (Sq.mt.)	Total Consumed Additional FAR Area (Sq.mt.)	Tnmt (No.)
Ground Floor	34.19	34.19	34.19	34.19	01
First Floor	34.19	34.19	34.19	34.19	00
Second Floor	34.19	34.19	34.19	34.19	00
Terrace Floor	0.00	0.00	0.00	0.00	00
Total :	102.57	102.57	102.57	102.57	01
Total Number of Same Buildings :	1				
Total :	102.57	102.57	102.57	102.57	01

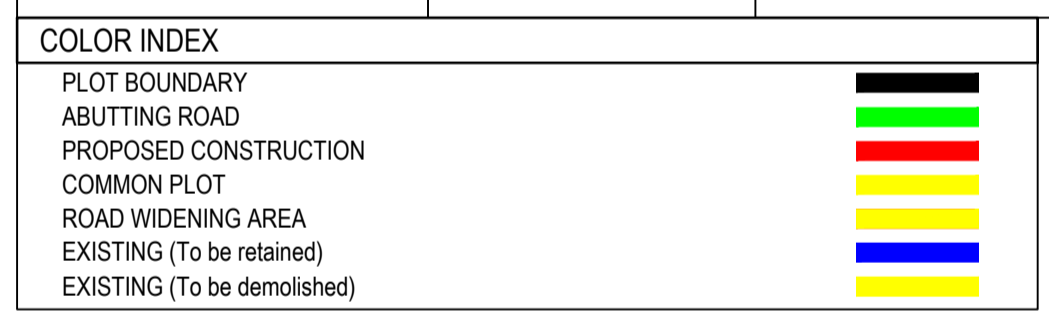

Buildingwise Floor FAR Details

Floor Name	Building Name A (RESIDENTIAL)		Total	
	Proposed Built Up Area (Sq.mt.)	Proposed FAR Area (Sq.mt.)	Total Proposed Built Up Area (Sq.mt.)	Total FAR Area (Sq.mt.)
Ground Floor	34.19	34.19	34.19	34.19
First Floor	34.19	34.19	34.19	34.19
Second Floor	34.19	34.19	34.19	34.19
Terrace Floor	0.00	0.00	0.00	0.00
Total :	102.57	102.57	102.57	102.57

Building USE/SUBUSE Details

Building Name	Building Use	Building SubUse	Building Structure
A (RESIDENTIAL)	Residential	Bungalow/ Dwelling / Non Apartment	Non-Highrise

FAR & Tenement Details (Table 4c-1)

Building	No. of Same Bldg	Total Built Up Area (Sq.mt.)	Proposed FAR Area (Sq.mt.) Resi.	Total FAR Area (Sq.mt.)	Total Consumed Additional FAR Area (Sq.mt.)	Tnmt (No.)
A (RESIDENTIAL)	1	102.57	102.57	102.57	102.57	01
Grand Total :	1	102.57	102.57	102.57	102.57	01

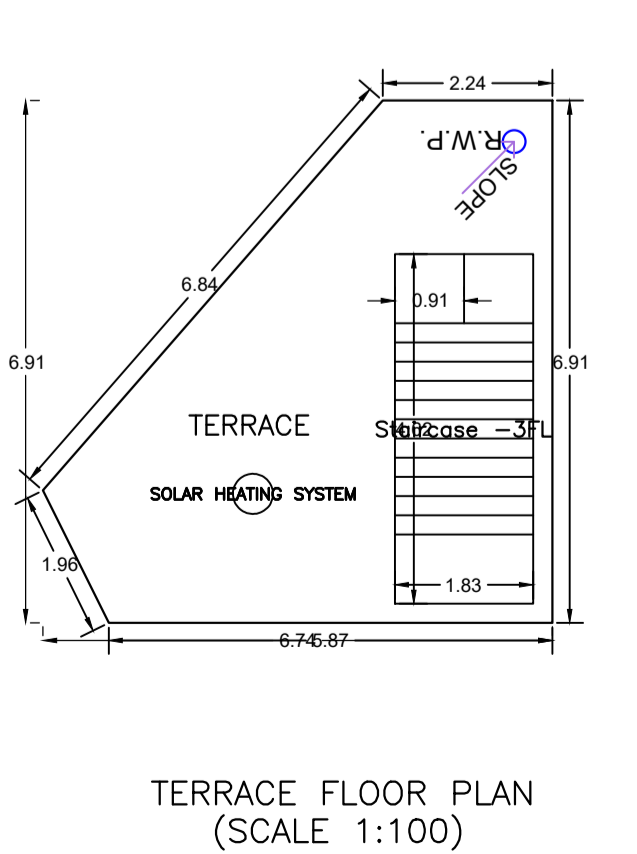
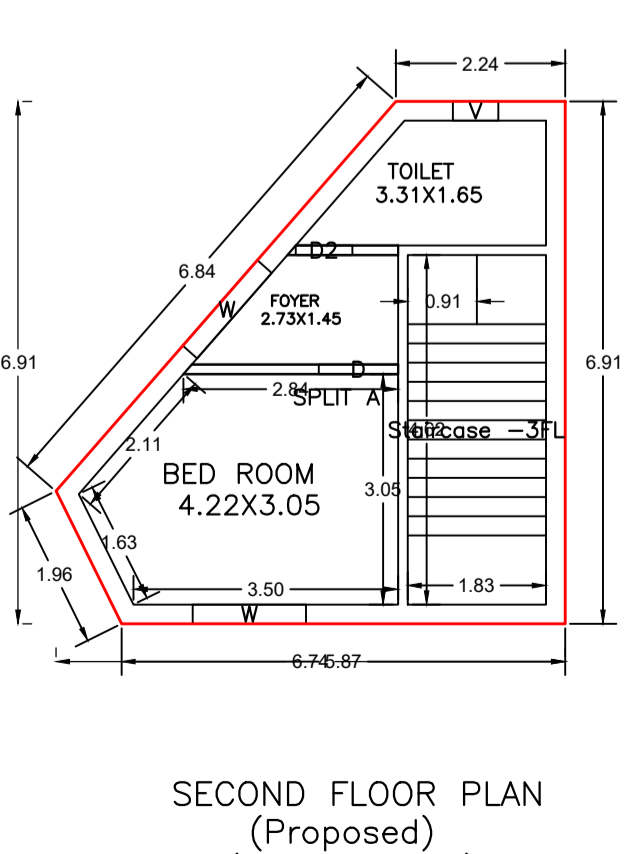
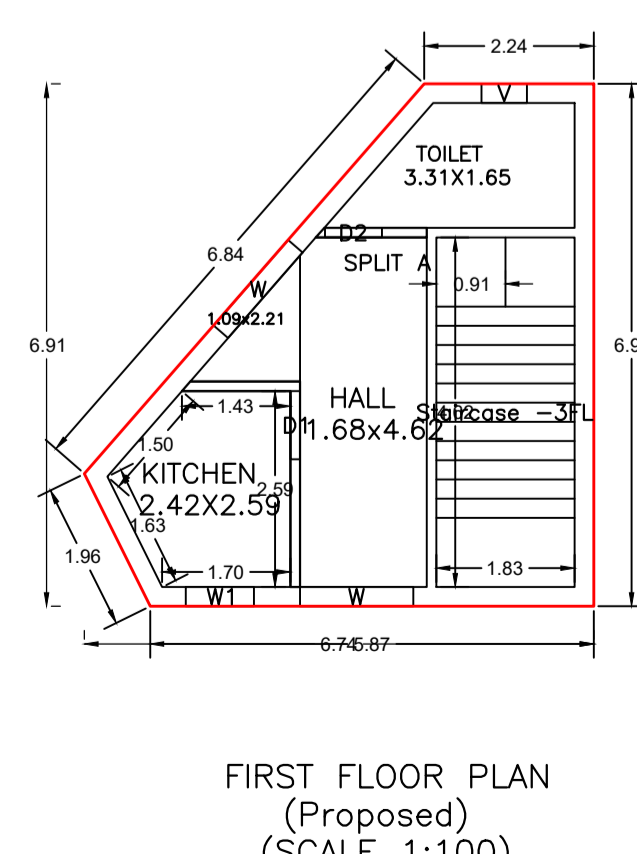
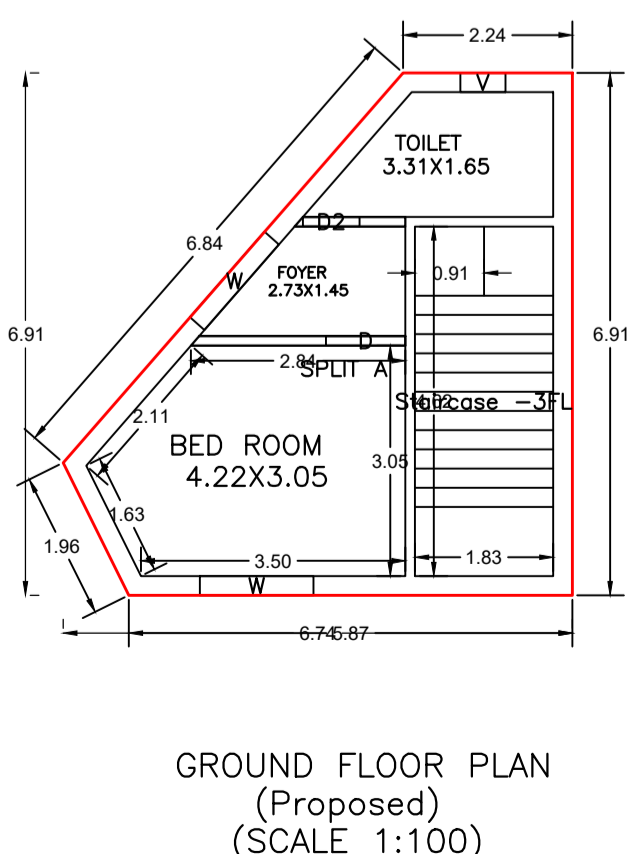
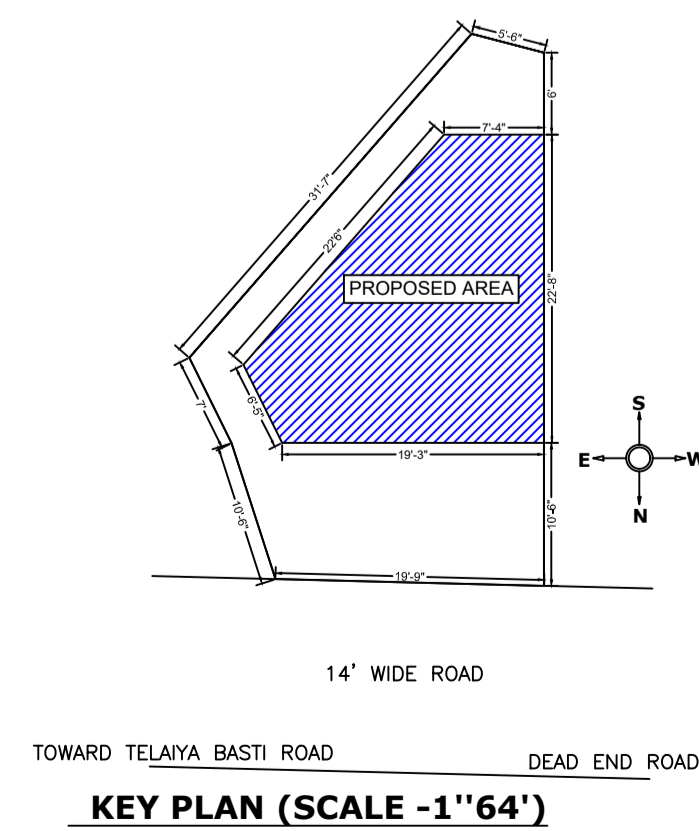

LTP NAME AND SIGNATURE	STRUCTURAL ENG'S NAME AND SIGNATURE	BUILDER NAME AND SIGNATURE	DIGITAL SIGNATURE
KIRAN KUMARI JNP/ENG/0001/2019			