

Project Title: KUNAL BHARDWAJ

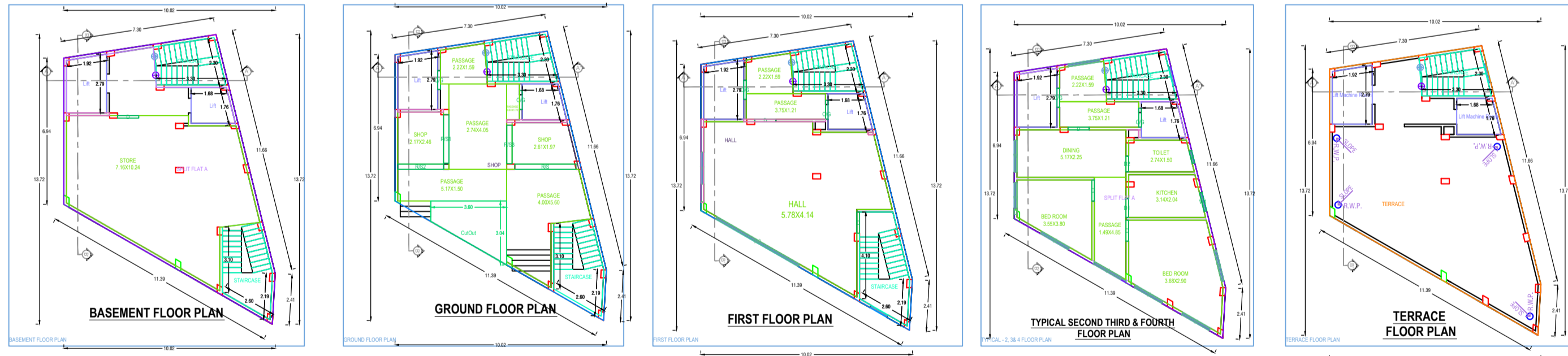
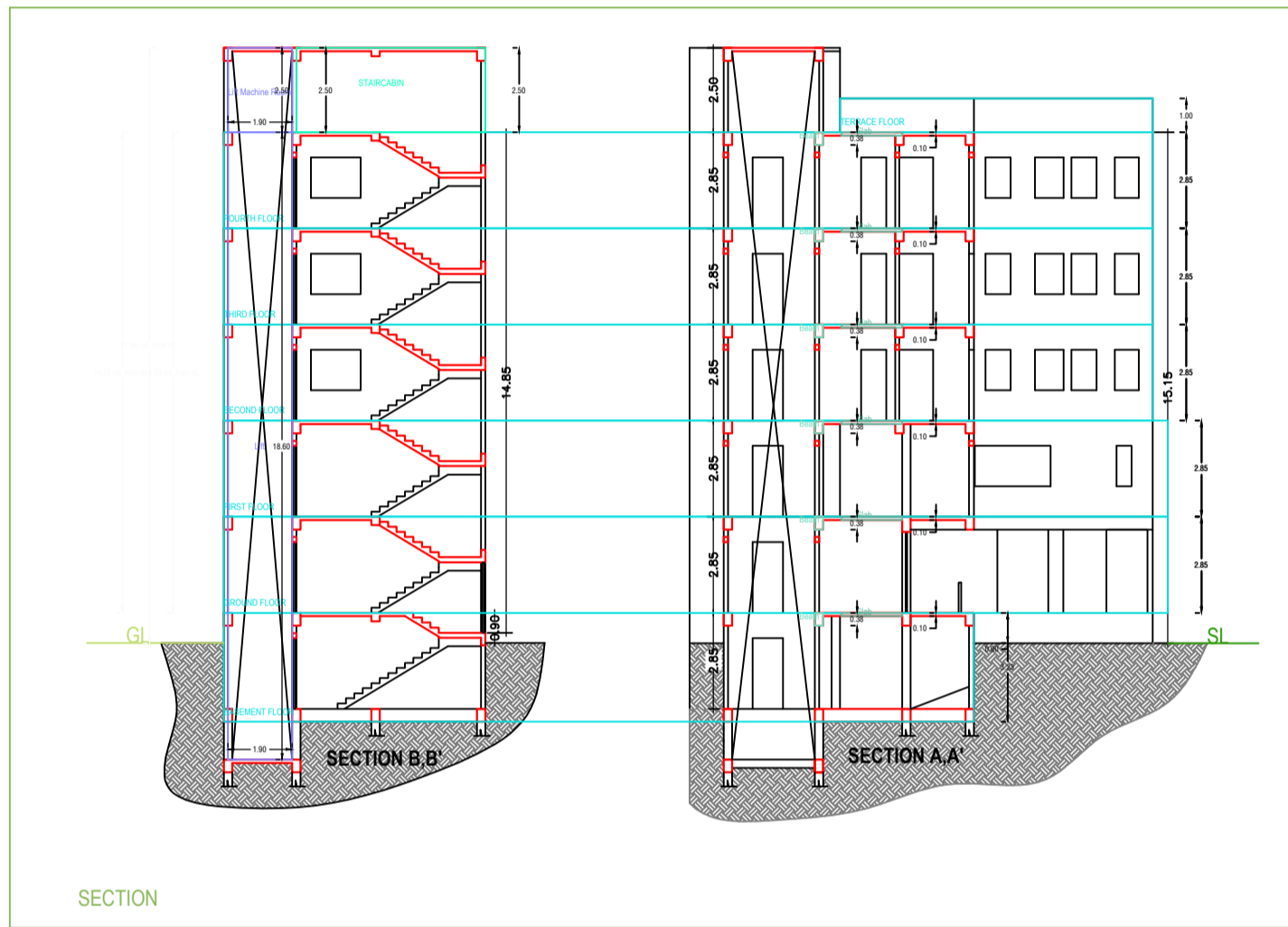
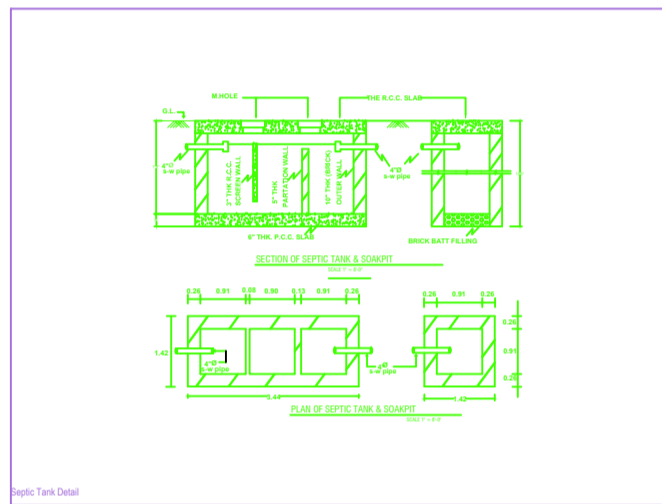
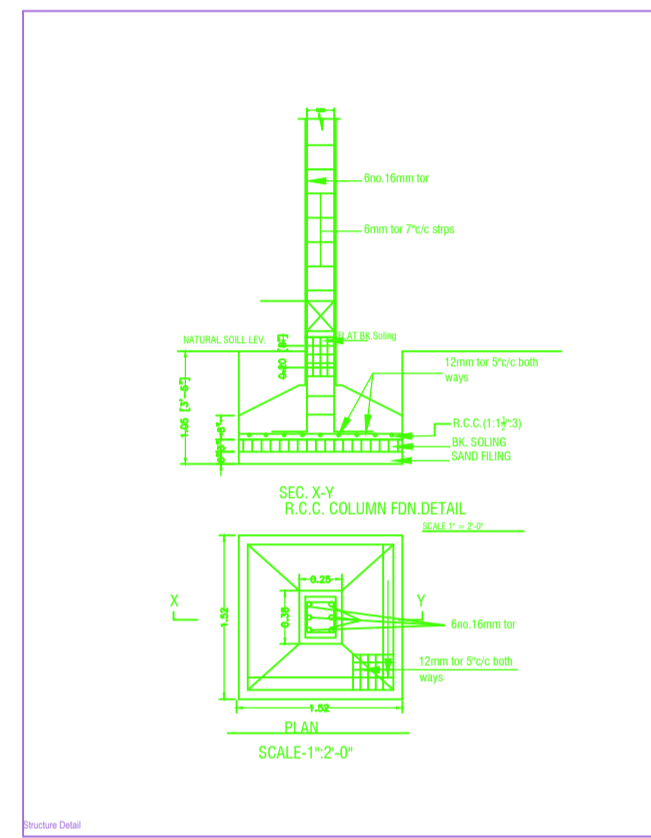
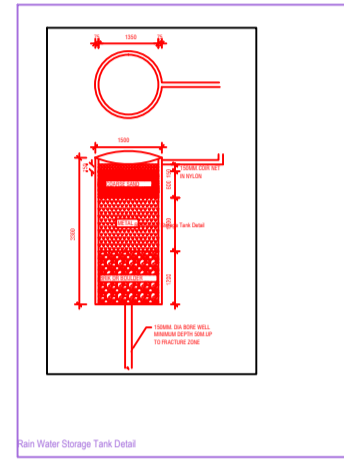
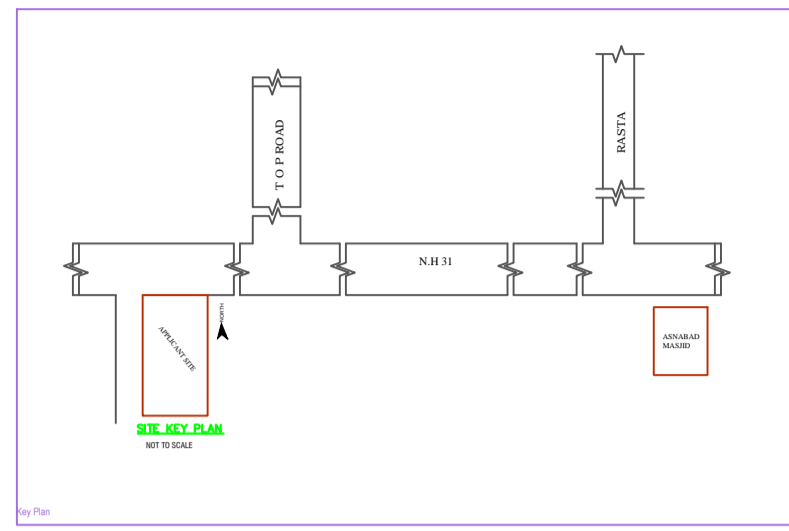

PROPERTY DETAIL	
Project No.	2023/01/01
Region	INDIA
City	DELHI
Plot No.	1234
Block No.	5678
Phase No.	9012
Scale	1:100
Date	2023-10-27

COLOR INDEX	
Green	Open Space
Red	Proposed Road
Blue	Water Body
Yellow	Other

PARKING CALCULATION	
Category	Area (sq.m)
Car	1000
Two Wheeler	500
Total	1500

MARGIN DETAIL	
Side Margin	3.00
Front Margin	5.00
Rear Margin	3.00

BASEMENT MARGIN DETAIL	
Side Margin	3.00
Front Margin	5.00
Rear Margin	3.00

FAR & Terment Details (Table 40-1)		
Building	Area (sq.m)	Volume (cu.m)
AA-1	1000	10000
Total	1000	10000

Room Name	Area (sq.m)	Volume (cu.m)
Basement	1000	10000
Ground Floor	1000	10000
First Floor	1000	10000
Typical Second/Third/Fourth	1000	10000
Terrace	1000	10000
Total	5000	50000

Room Name	Area (sq.m)	Volume (cu.m)
Basement	1000	10000
Ground Floor	1000	10000
First Floor	1000	10000
Typical Second/Third/Fourth	1000	10000
Terrace	1000	10000
Total	5000	50000

Room Name	Area (sq.m)	Volume (cu.m)
Basement	1000	10000
Ground Floor	1000	10000
First Floor	1000	10000
Typical Second/Third/Fourth	1000	10000
Terrace	1000	10000
Total	5000	50000