

SITE PLAN

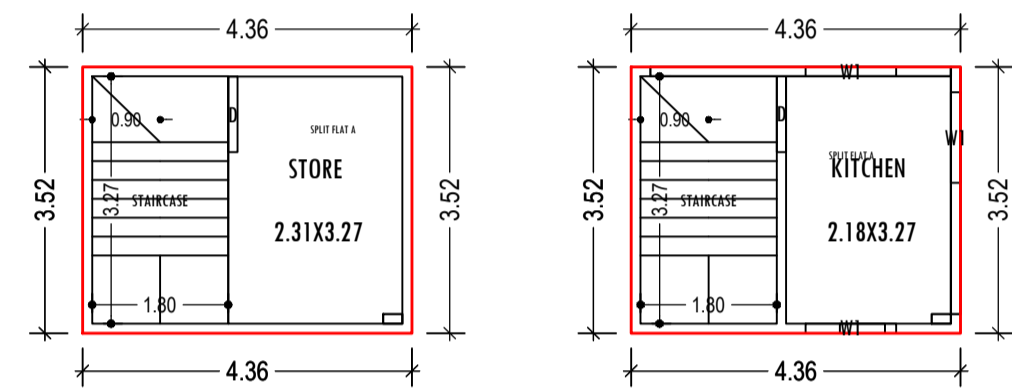

BASEMENT FLOOR PLAN (Proposed) (SCALE 1:100)

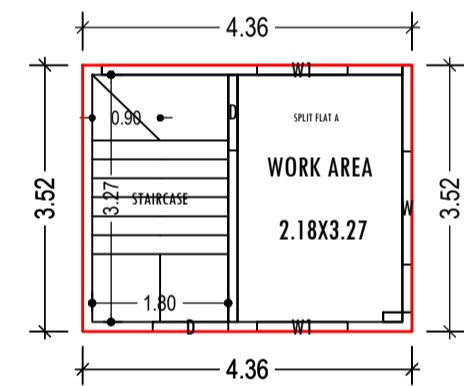

GROUND FLOOR PLAN (Proposed) (SCALE 1:100)

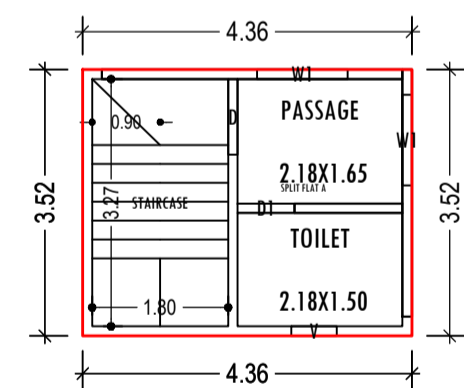

FIRST FLOOR PLAN (Proposed) (SCALE 1:100)

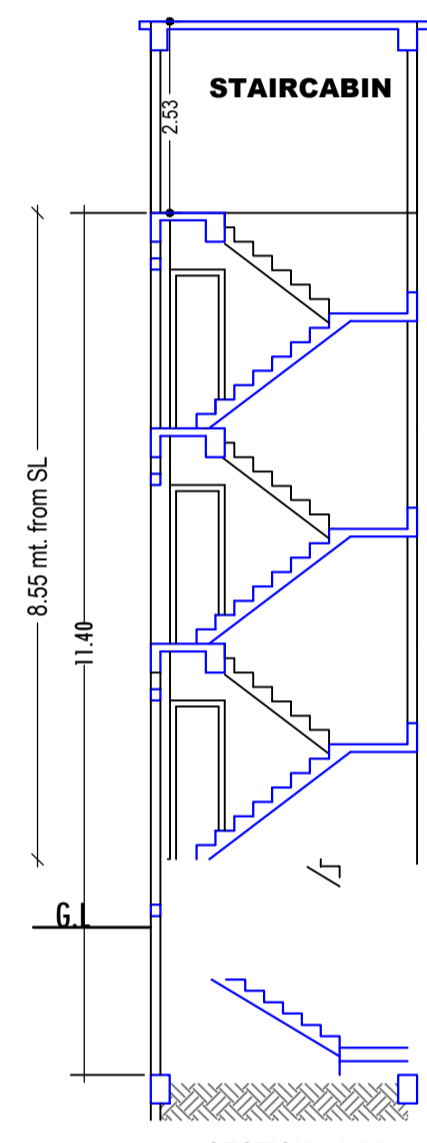

SECTION - A-A' SCALE - 1=100

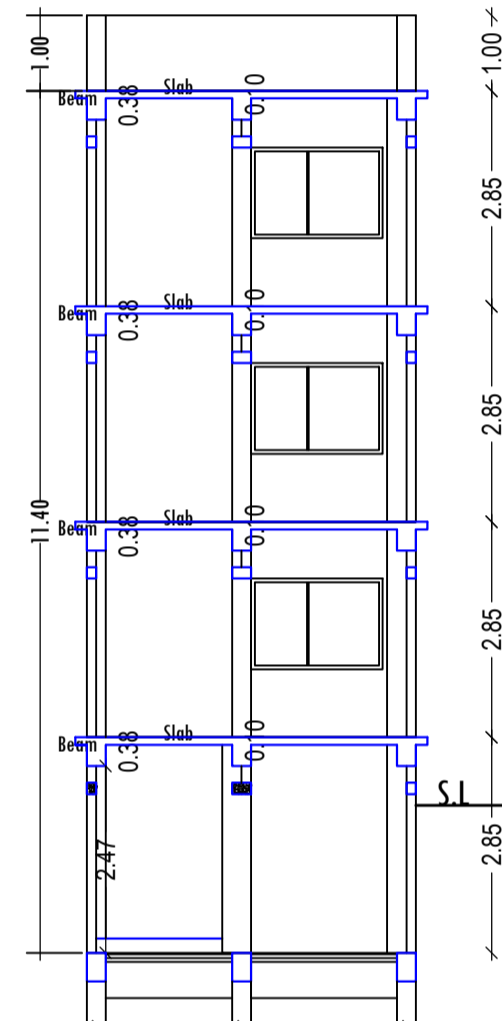

SECTION - B-B' SCALE - 1=100

UnitBUA Table for Building :AA (1 SRI RAJESH KUMAR 2 SMT NILAM KUMARI)

FLOOR	Name	UnitBUA Type	UnitBUA Area	Carpet Area	No. of Rooms	No. of Tenement
BASEMENT FLOOR PLAN	SPLIT FLAT A	FLAT	30.16	29.47	1	1
GROUND FLOOR PLAN	SPLIT FLAT A	FLAT	0.00	0.00	1	0
FIRST FLOOR PLAN	SPLIT FLAT A	FLAT	0.00	0.00	2	0
SECOND FLOOR PLAN	SPLIT FLAT A	FLAT	0.00	0.00	1	0
Total:	-	-	30.16	29.47	5	1

SCHEDULE OF DOOR:

BUILDING NAME	NAME	LENGTH	HEIGHT	NOS
AA (1 SRI RAJESH KUMAR 2 SMT NILAM KUMARI)	D1	0.75	2.10	01
AA (1 SRI RAJESH KUMAR 2 SMT NILAM KUMARI)	D	1.00	2.10	04

SCHEDULE OF WINDOW/VENTILATION:

BUILDING NAME	NAME	LENGTH	HEIGHT	NOS
AA (1 SRI RAJESH KUMAR 2 SMT NILAM KUMARI)	V	0.60	0.60	01
AA (1 SRI RAJESH KUMAR 2 SMT NILAM KUMARI)	W1	0.60	0.60	01
AA (1 SRI RAJESH KUMAR 2 SMT NILAM KUMARI)	W1	1.20	1.20	07
AA (1 SRI RAJESH KUMAR 2 SMT NILAM KUMARI)	W	1.50	1.20	01

Building :AA (1 SRI RAJESH KUMAR 2 SMT NILAM KUMARI)

Floor Name	Total Built Up Area (Sq.mt.)	Proposed FAR Area (Sq.mt.)	Total FAR Area (Sq.mt.)	Total Consumed Additional FAR Area (Sq.mt.)	Tnmt (No.)
Basement Floor	15.33	15.33	15.33	15.33	01
Ground Floor	15.33	15.33	15.33	15.33	00
First Floor	15.33	15.33	15.33	15.33	00
Second Floor	15.33	15.33	15.33	15.33	00
Terrace Floor	0.00	0.00	0.00	0.00	00
Total:	61.32	61.32	61.32	61.32	01
Total Number of Same Buildings	1				
Total:	61.32	61.32	61.32	61.32	01

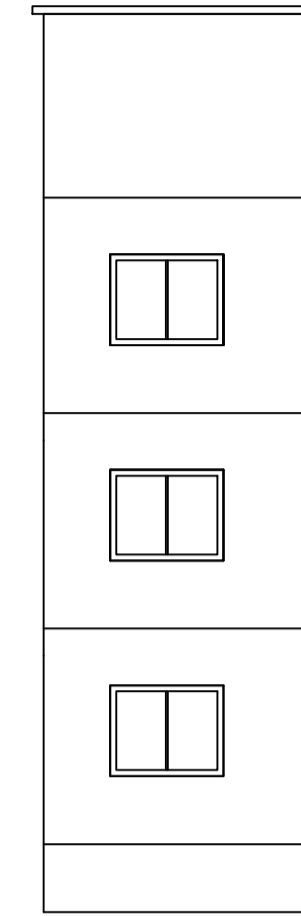

SIDE ELEVATION SCALE - 1=100

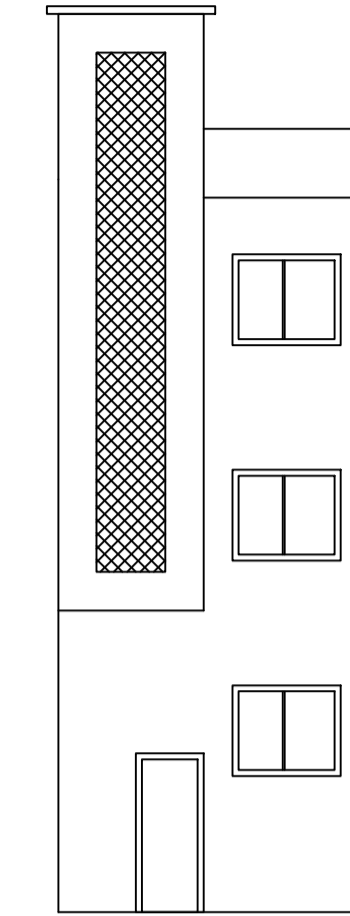

FRONT ELEVATION SCALE - 1=100

AREA STATEMENT		VERSION NO.: 1.0.66
JHUMRITLAIYA NAGAR PARISHAD		VERSION DATE: 16/10/2020
PROJECT DETAIL:		
Region: JHARKHAND URBAN	Plot Use: Residential	
District: KODERMA	Plot SubUse: Bungalow/ Dwelling / Non Apartment	
Authority: JHUMRITLAIYA NAGAR PARISHAD	PlotNearby/ReligiousStructure: NA	
Inward No: JNP/BP/0123/W10/2023	Plot/SubPlot No: 7457	
Application Type: General Proposal	North: Plot No. - LAND OF BINOD KUMAR	
Project Type: Building Permission	South: Plot No. - LAND OF BINAY KUMAR MODI	
Nature of Development: New	East: Road Width - 4.57M WIDE ROAD	
Location of Development Area: Old Area	West: Plot No. - OWN LAND OF VENDER	
AREA DETAILS:		
AREA OF PLOT (Minimum)	(A)	40.94
NET AREA OF PLOT(Gross Plot Area - Deduction from Gross Plot area)	(A-Deductions)	40.94
Deduction for Balance Plot Area(from Gross Plot Area)		
Common Plot		3.16
Total		3.16
BALANCE AREA OF PLOT(Net Plot Area - Recreational/Amenity space)	(A-Deductions)	37.78
PLOT AREA FOR COVERAGE(Net Plot Area)	(A-Deductions)	40.94
Plot Area for FAR (Net Plot Area + RoadWidening Area)	(A-Deductions)	40.94
COVERAGE CHECK		
Permissible Coverage area (70.00 %)		28.66
Proposed Coverage Area (37.45 %)		15.33
Total Prop. Coverage Area (37.45 %)		15.33
Balance coverage area (32.56 %)		13.33
FAR CHECK		
Perm. FAR Area (1.500)		61.41
Total Perm. FAR area		61.41
Residential FAR		61.33
Proposed FAR Area		61.33
Total Proposed FAR Area		61.33
Consumed FAR (Factor)		1.50
Balance FAR Area		0.08
BUILT UP AREA CHECK		
Total Proposed BuiltUp Area		61.32
ARCHITECT (Regd)	MD SHOAB ALAM	
ENGINEER (Regd)		
SUPERVISOR (Regd)		
OWNER (Regd)	1 SRI RAJESH KUMAR 2 SMT NILAM KUMARI	
DEVELOPMENT AUTHORITY		LOCAL BODY

COLOR INDEX	
PLOT BOUNDARY	Black
ABUTTING ROAD	Red
PROPOSED CONSTRUCTION	Green
COMMON PLOT	Yellow
ROAD WIDENING AREA	Blue
EXISTING (To be retained)	Orange
EXISTING (To be demolished)	Purple

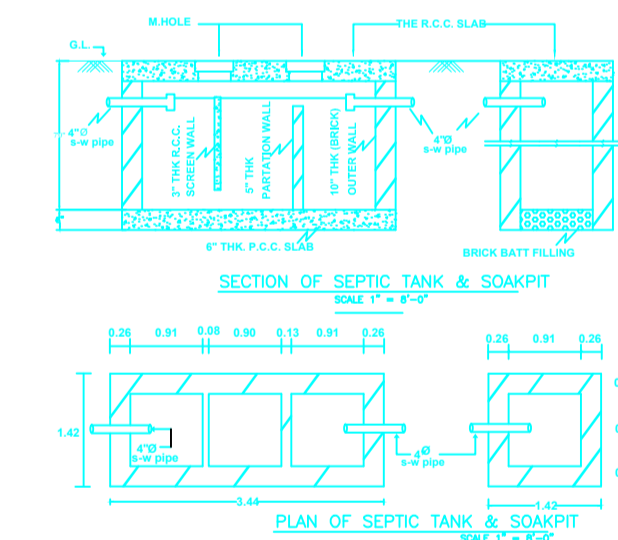
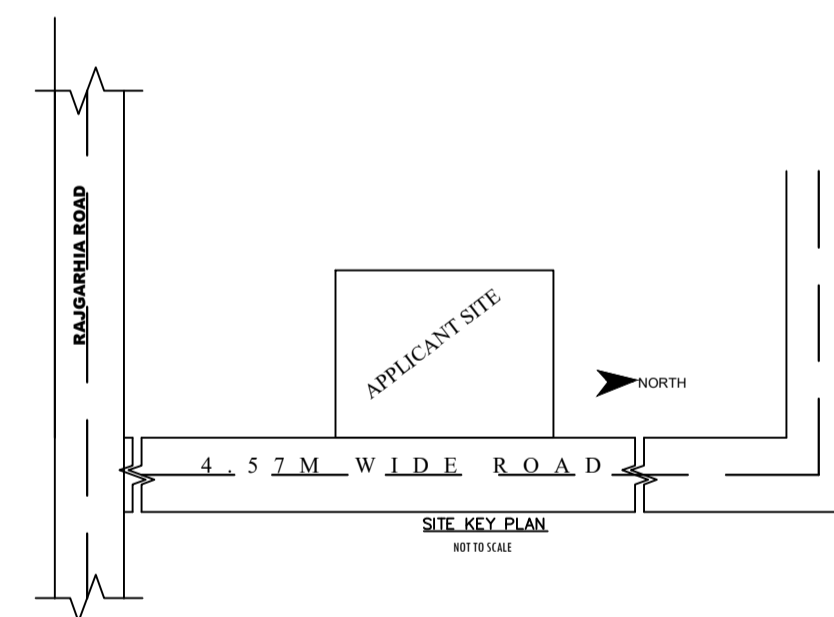

Buildingwise Floor FAR Details

Floor Name	Building Name		Total	
	AA (1 SRI RAJESH KUMAR 2 SMT NILAM KUMARI)	Total	Proposed Built Up Area (Sq.mt.)	Total FAR Area (Sq.mt.)
Basement Floor	15.33	15.33	15.33	15.33
Ground Floor	15.33	15.33	15.33	15.33
First Floor	15.33	15.33	15.33	15.33
Second Floor	15.33	15.33	15.33	15.33
Terrace Floor	0.00	0.00	0.00	0.00
Total:	61.32	61.32	61.32	61.32

Building USE/SUBUSE Details

Building Name	Building Use	Building SubUse	Building Structure
AA (1 SRI RAJESH KUMAR 2 SMT NILAM KUMARI)	Residential	Bungalow/ Dwelling / Non Apartment	Non-Highrise

FAR & Tenement Details (Table 4c-1)

Building	No. of Same Bldg	Total Built Up Area (Sq.mt.)	Proposed FAR Area (Sq.mt.)	Total FAR Area (Sq.mt.)	Total Consumed Additional FAR Area (Sq.mt.)	Tnmt (No.)
AA (1 SRI RAJESH KUMAR 2 SMT NILAM KUMARI)	1	61.32	61.32	61.32	61.32	01
Grand Total:	1	61.32	61.32	61.32	61.32	01

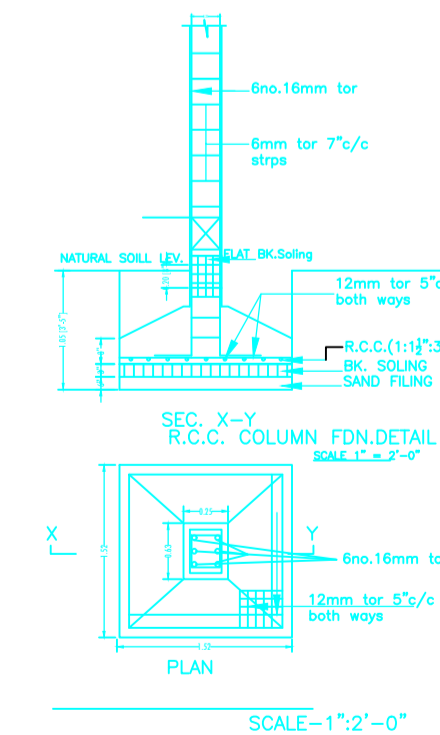
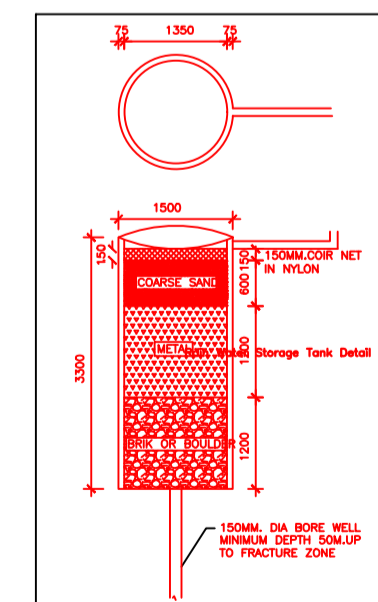

This is system generated report and does not require any signature. This is authorised document under rule 23 of AP building rules. For further confirmation you can access the department website www.apdpm.s.gov.in with file number

LTP NAME AND SIGNATURE	STRUCTURAL ENG'S NAME AND SIGNATURE	BUILDER NAME AND SIGNATURE
MD SHOAB ALAM JNP/ENG/0001/2017		