

Proposal Basic Information

Proposal File No.	JNP/BP/0048/W10/2024
Owner Name	SMT. SANTOSHI DEVI
Khata No	631
Plot No	7457
Village Name	Tilaiya
Use	Residential
SubUse	Bungalow/ Dwelling / Non Apartment

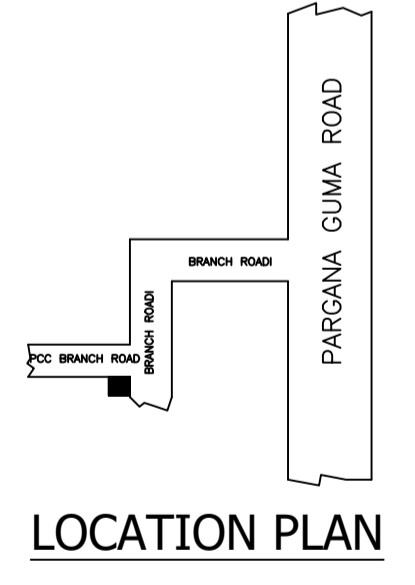
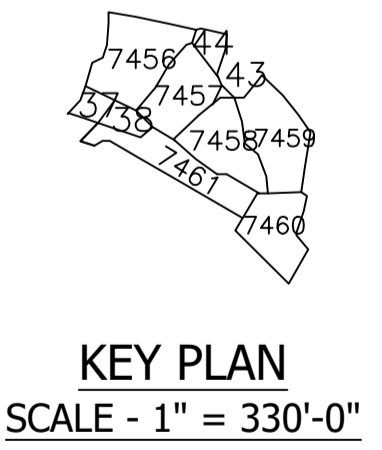
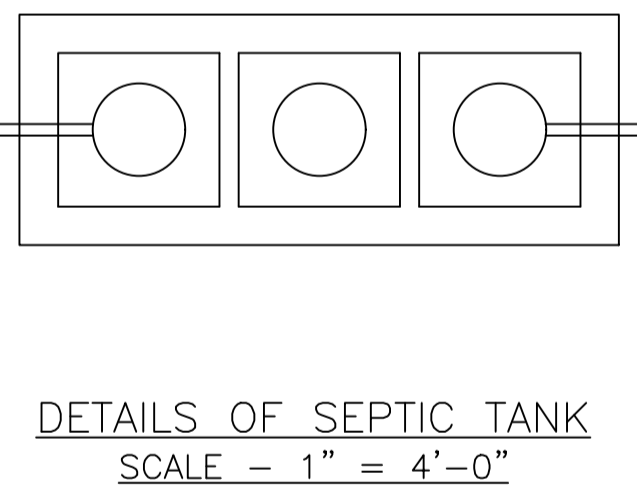
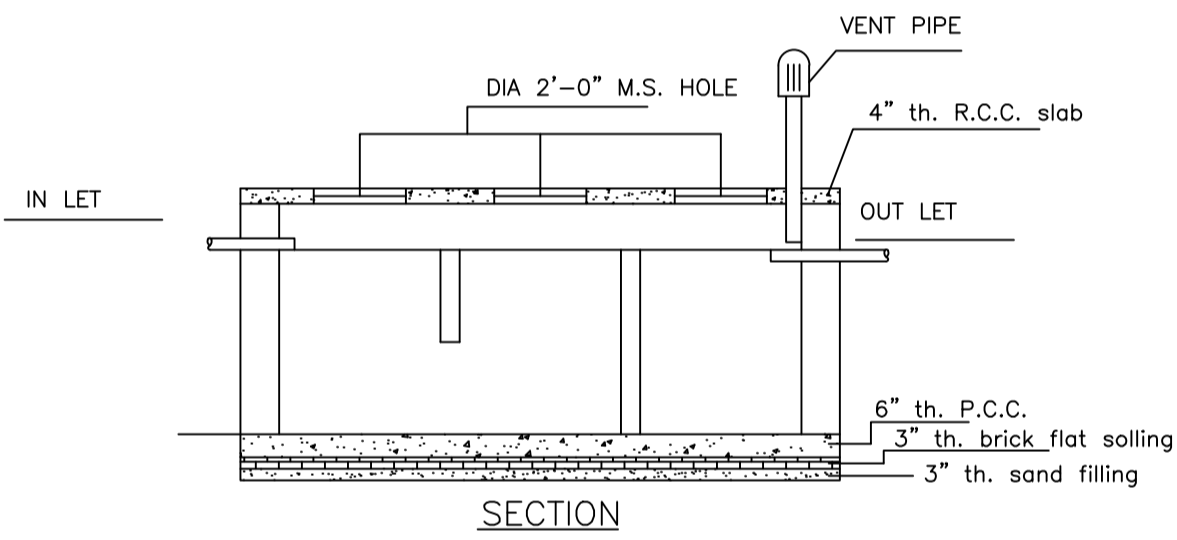
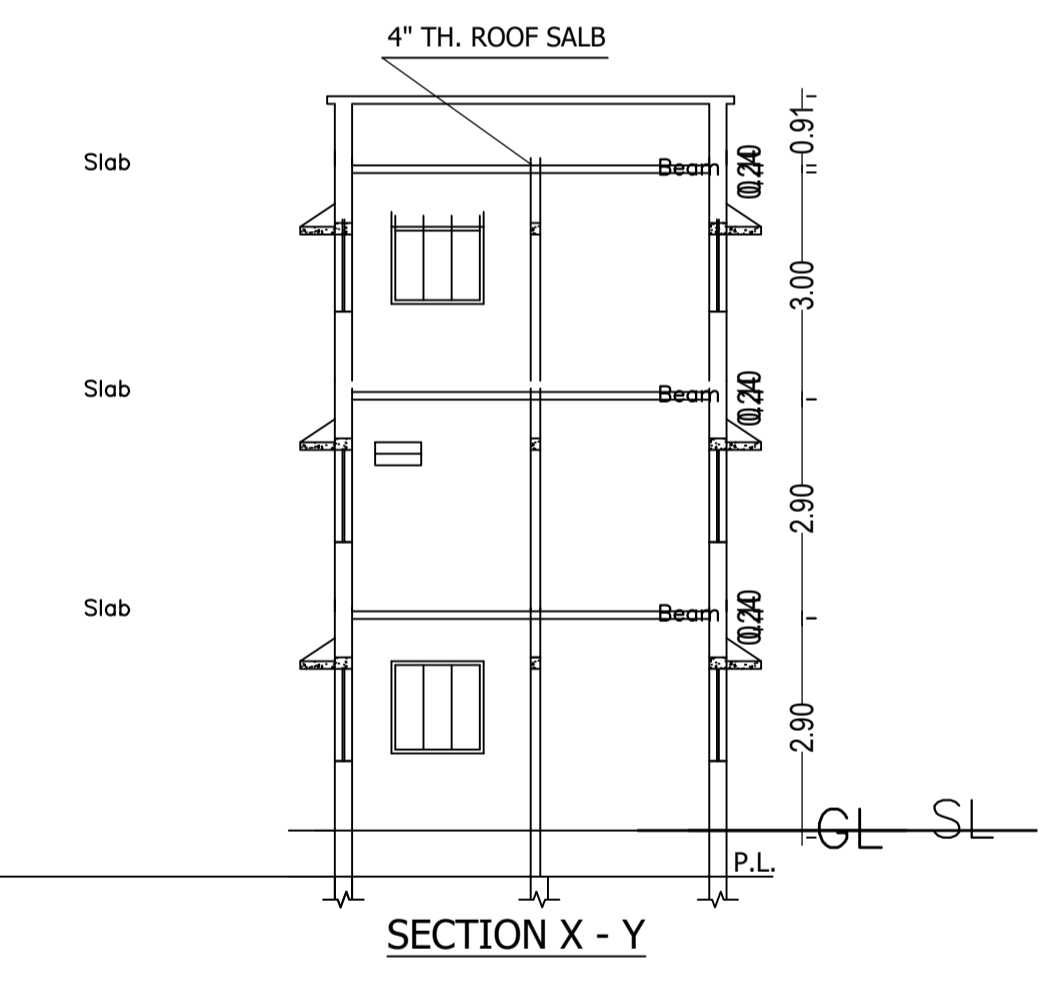
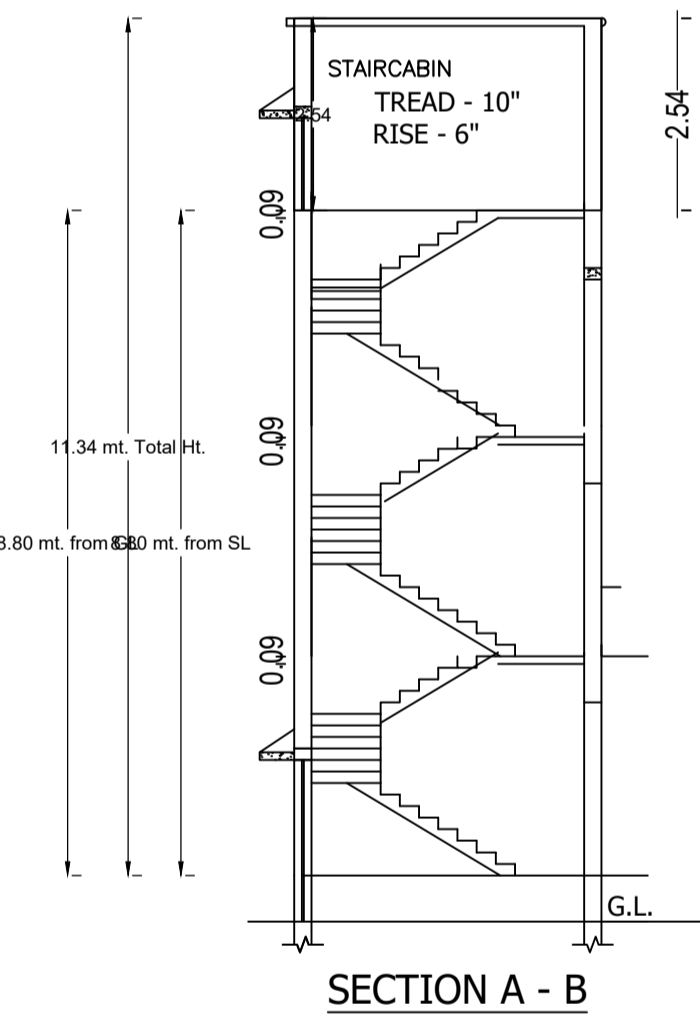
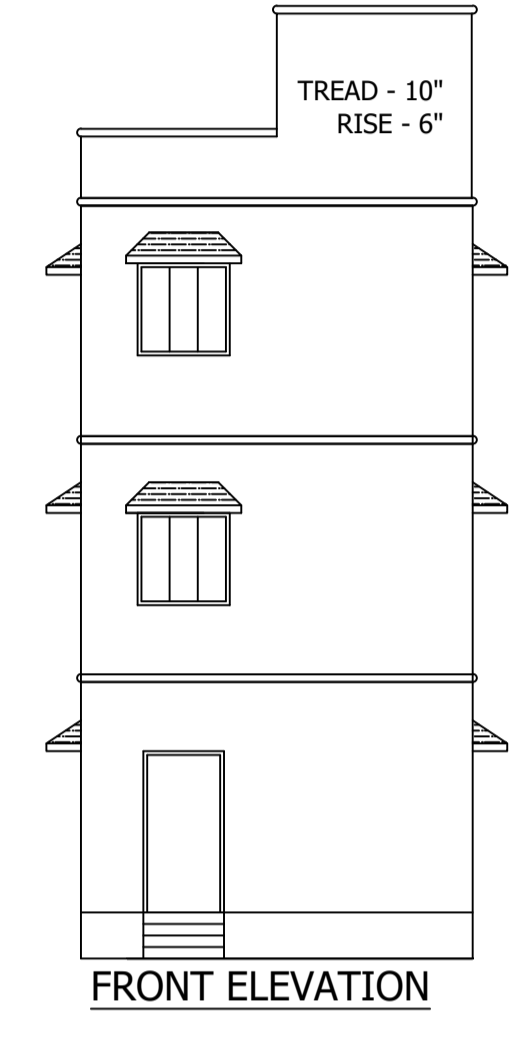
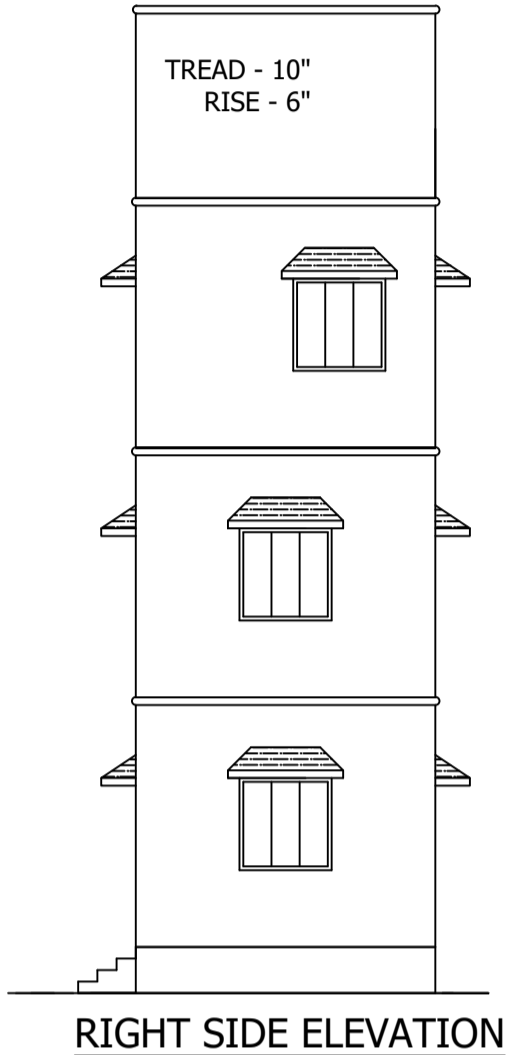
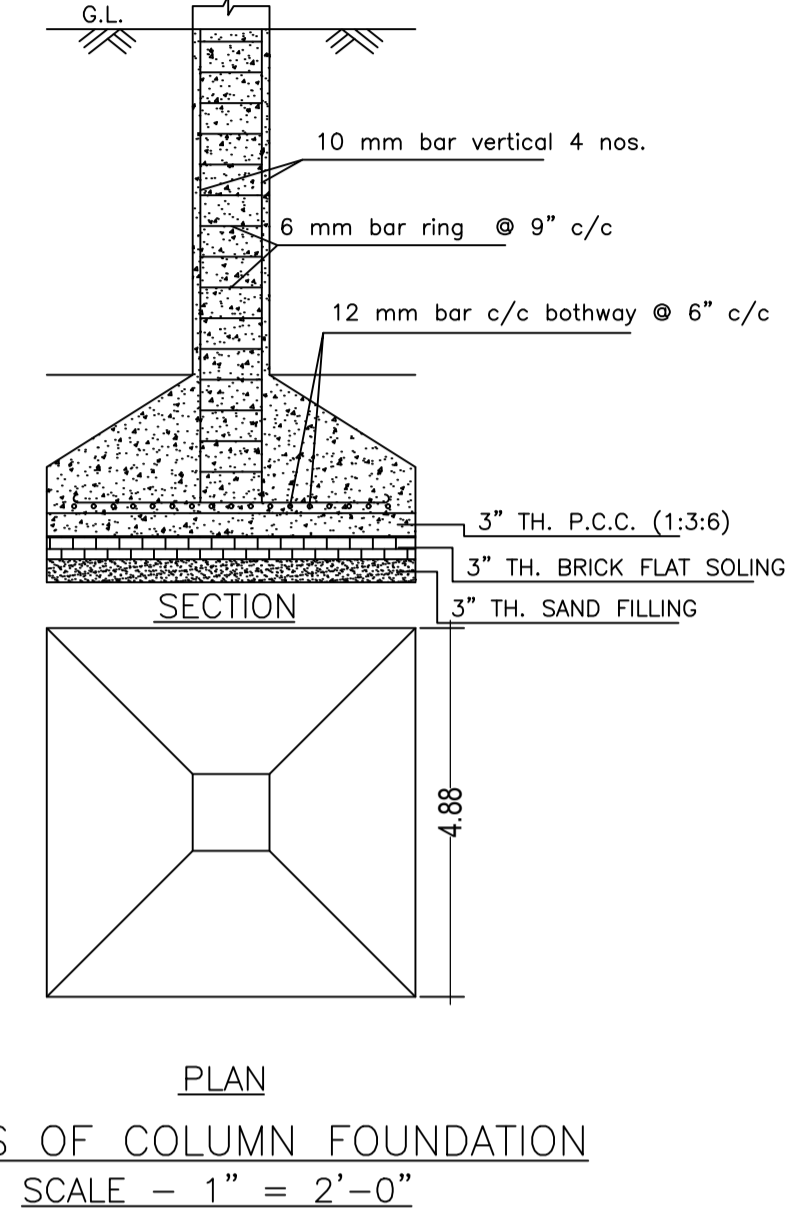
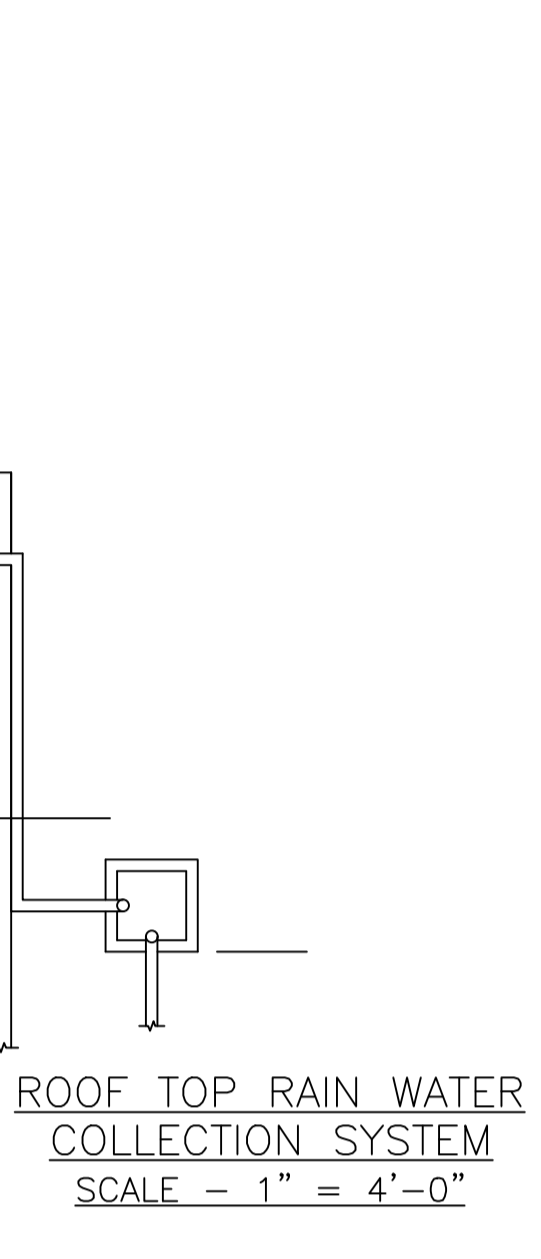
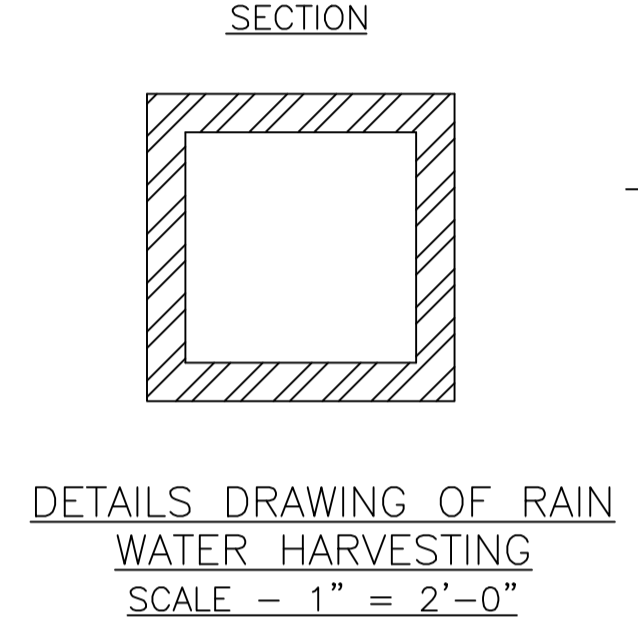
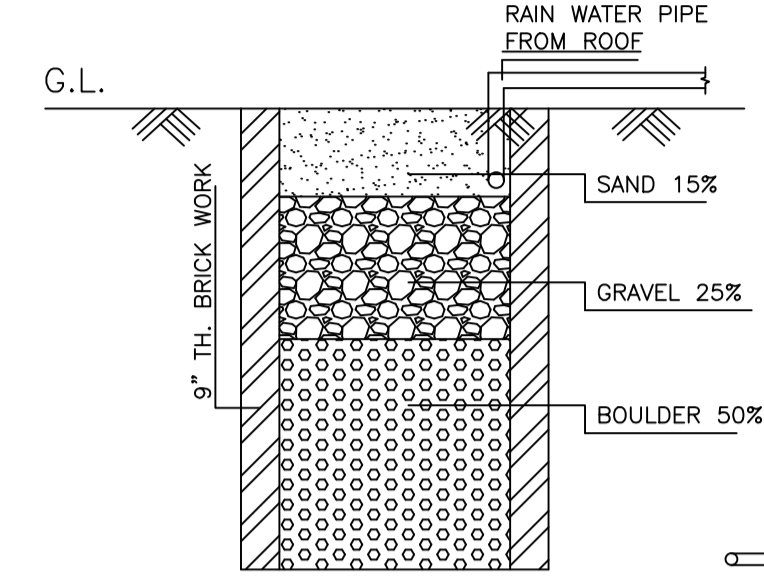
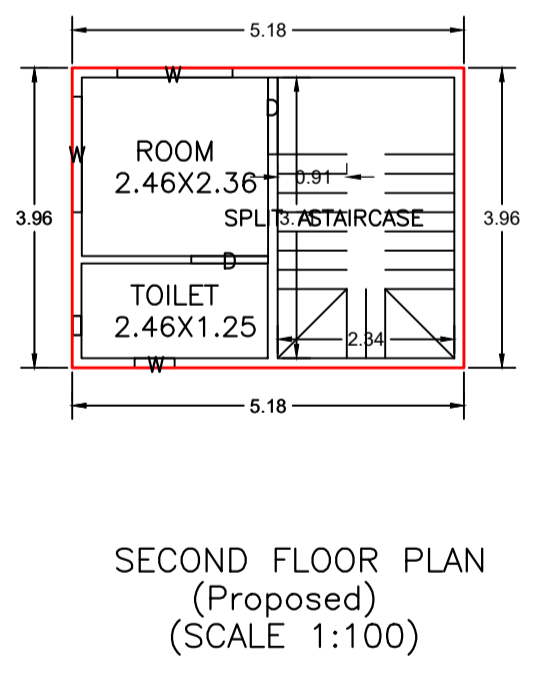
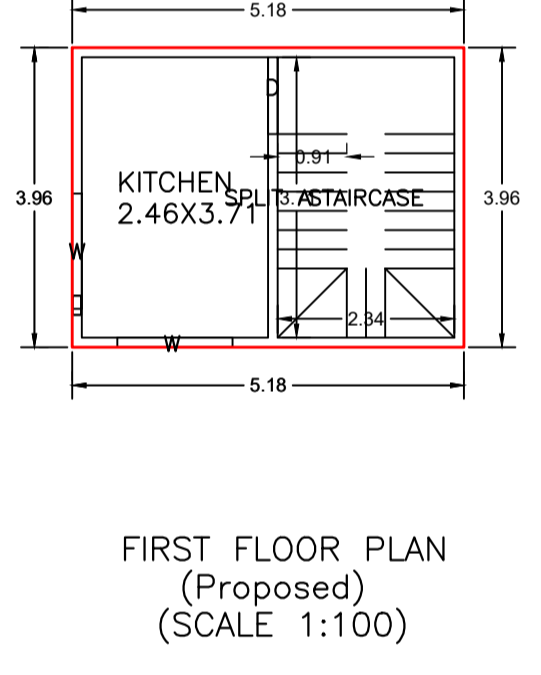
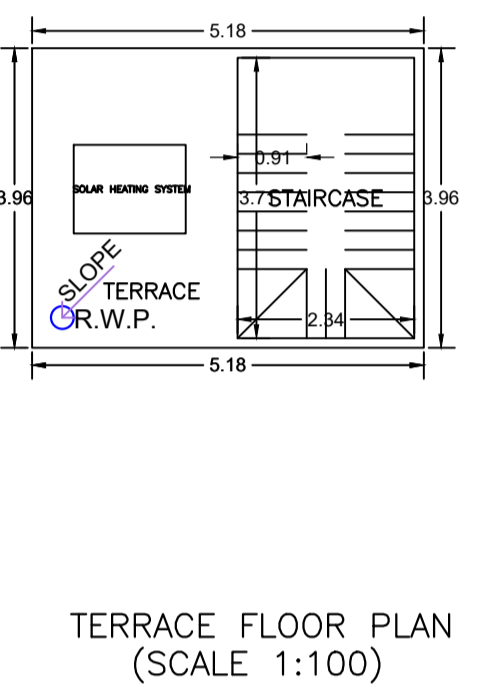
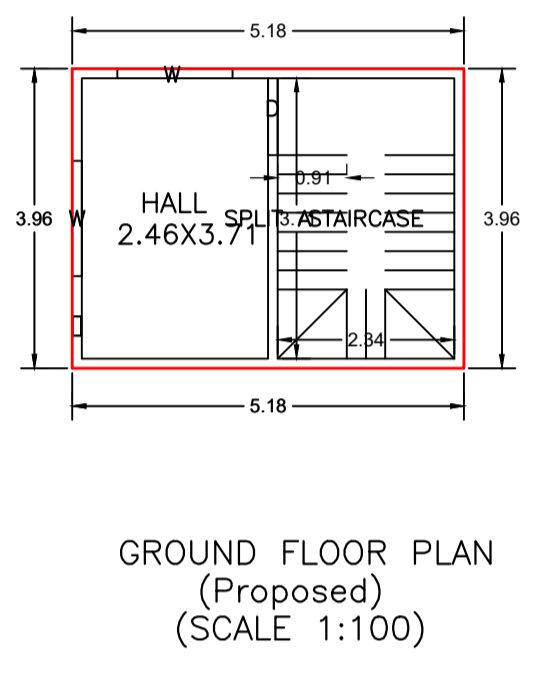
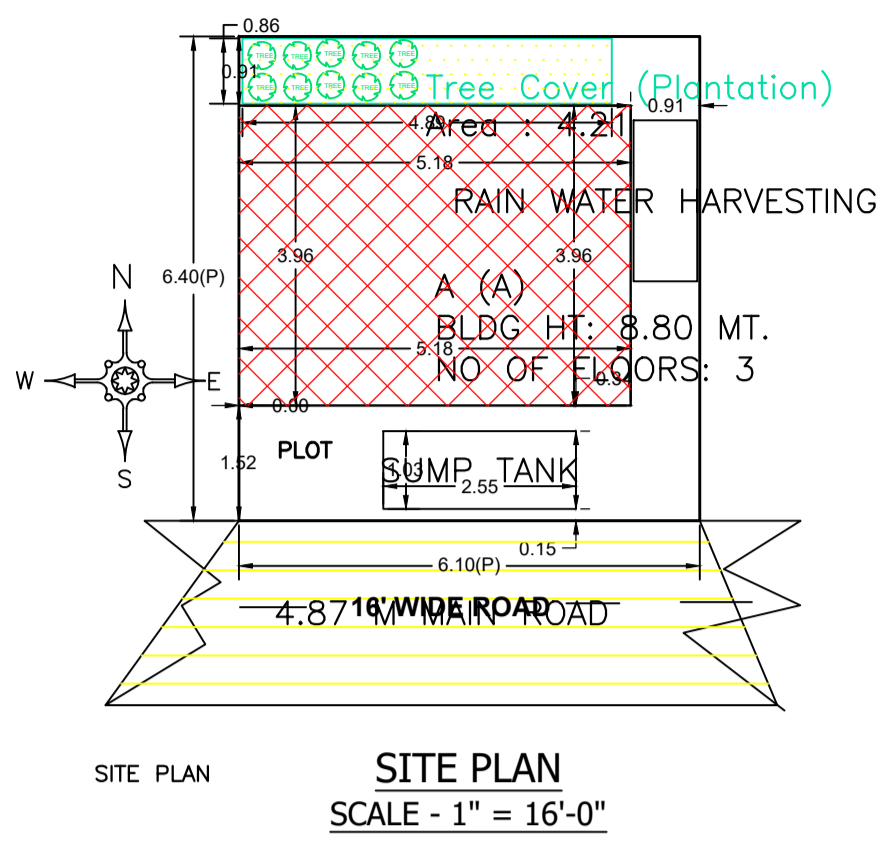

AREA STATEMENT	JHUMRITILAIYA NAGAR PARISHAD	VERSION NO. 1.0.70	VERSION DATE: 16/10/2020
PROJECT DETAIL:	Region: JHARKHAND URBAN LOCAL BODIES	Plot Use: Residential	
	District: KODERMA	Plot SubUse: Bungalow/ Dwelling / Non Apartment	
	Authority: JHUMRITILAIYA NAGAR PARISHAD	PlotNearbyReligiousStructure: NA	
	Inward No: JNP/BP/0048/W10/2024	Plot/SubPlot No: 7457	
	Application Type: General Proposal	North: Plot No. - LAND OF SMT. ARTI DEVI	
	Project Type: Building Permission	South: Plot No. - LAND OF SMT. SAVITRI DEVI	
	Nature of Development: New	East: Plot No. - DRAIN	
	Location of Development Area: Old Area	West: Road Width - 4.87	
AREA DETAILS:			SQ.MT.
AREA OF PLOT (Minimum)	(A)		39.04
NET AREA OF PLOT(Gross Plot Area - Deduction from Gross Plot area)	(A-Deductions)		39.04
Deduction for Balance Plot Area(from Gross Plot Area)			
Common Plot			4.21
Total			4.21
BALANCE AREA OF PLOT(Net Plot Area - Recreational/Amenity space)	(A-Deductions)		34.82
PLOT AREA FOR COVERAGE(Net Plot Area)	(A-Deductions)		39.04
Plot Area for FAR (Net Plot Area + Road/Widening Area)	(A-Deductions)		39.04
COVERAGE CHECK			
Permissible Coverage area ( 70.00 % )			27.33
Proposed Coverage Area ( 52.62 % )			20.54
Total Prop. Coverage Area ( 52.62 % )			20.54
Balance coverage area ( 17.39 % )			6.79
FAR CHECK			
Perm. FAR Area ( 1.800 )			70.27
Total Perm. FAR area			70.27
Residential FAR			61.62
Proposed FAR Area			61.62
Total Proposed FAR Area			61.62
Consumed FAR (Factor)			1.58
Balance FAR Area			8.65
Total Proposed BuiltUp Area			61.62
BUILT UP AREA CHECK			
ARCHITECT (Regd)	DEEPAK KUMAR SAW		
ENGINEER (Regd)			
SUPERVISOR (Regd)			
OWNER (Regd)	SMT. SANTOSHI DEVI		
DEVELOPMENT AUTHORITY		LOCAL BODY	

COLOR INDEX	
PLOT BOUNDARY	Black
ABUTTING ROAD	Green
PROPOSED CONSTRUCTION	Red
COMMON PLOT	Yellow
ROAD WIDENING AREA	Blue
EXISTING (To be retained)	Orange
EXISTING (To be demolished)	White

Floor Name	Building Name A (A)		Total	
	Proposed Built Up Area (Sq.mt.)	Proposed FAR Area (Sq.mt.)	Total Proposed Built Up Area (Sq.mt.)	Total FAR Area (Sq.mt.)
Ground Floor	20.54	20.54	20.54	20.54
First Floor	20.54	20.54	20.54	20.54
Second Floor	20.54	20.54	20.54	20.54
Terrace Floor	0.00	0.00	0.00	0.00
Total:	61.62	61.62	61.62	61.62

Building USE/SUBUSE Details			
Building Name	Building Use	Building SubUse	Building Structure
A (A)	Residential	Bungalow/ Dwelling / Non Apartment	Non-Highrise

FAR & Tenement Details (Table 4c-1)						
Building	No. of Same Bldg	Total Built Up Area (Sq.mt.)	Proposed FAR	Total FAR Area (Sq.mt.)	Total Consumed Additional FAR Area (Sq.mt.)	Tnmt (No.)
			Area (Sq.mt.)			
A (A)	1	61.62	61.62	61.62	61.62	01
Grand Total:	1	61.62	61.62	61.62	61.62	01

Building :A (A)					
Floor Name	Total Built Up Area (Sq.mt.)	Proposed FAR	Total FAR Area (Sq.mt.)	Total Consumed Additional FAR Area (Sq.mt.)	Tnmt (No.)
		Area (Sq.mt.)			
Ground Floor	20.54	20.54	20.54	20.54	01
First Floor	20.54	20.54	20.54	20.54	00
Second Floor	20.54	20.54	20.54	20.54	00
Terrace Floor	0.00	0.00	0.00	0.00	00
Total:	61.62	61.62	61.62	61.62	01
Total Number of Same Buildings	1				
Total:	61.62	61.62	61.62	61.62	01

SCHEDULE OF DOOR:				
BUILDING NAME	NAME	LENGTH	HEIGHT	NOS
A (A)	D	1.02	2.10	04
SCHEDULE OF WINDOW/VENTILATION:				
BUILDING NAME	NAME	LENGTH	HEIGHT	NOS
A (A)	W	0.53	1.20	01
A (A)	W	1.52	1.20	06

UnitBUA Table for Building :A (A)						
FLOOR	Name	UnitBUA Type	UnitBUA Area	Carpet Area	No. of Rooms	No. of Tenement
GROUND FLOOR PLAN	SPLIT A	FLAT	61.62	61.54	1	1
FIRST FLOOR PLAN	SPLIT A	FLAT	0.00	0.00	1	0
SECOND FLOOR PLAN	SPLIT A	FLAT	0.00	0.00	2	0
Total:	-	-	61.62	61.54	4	1

LTP NAME AND SIGNATURE	STRUCTURAL ENG'S NAME AND SIGNATURE	BUILDER NAME AND SIGNATURE	DIGITAL SIGNATURE
DEEPAK KUMAR SAW JNP/ENG/0004/2023			