

Proposal Basic Information

Proposal File No.	JNP/BP/0042/W14/2024
Owner Name	SMT MUNNI DEVI
Khata No	1212
Plot No	7143
Village Name	Tilaiya
Use	Residential
SubUse	Bungalow/ Dwelling / Non Apartment

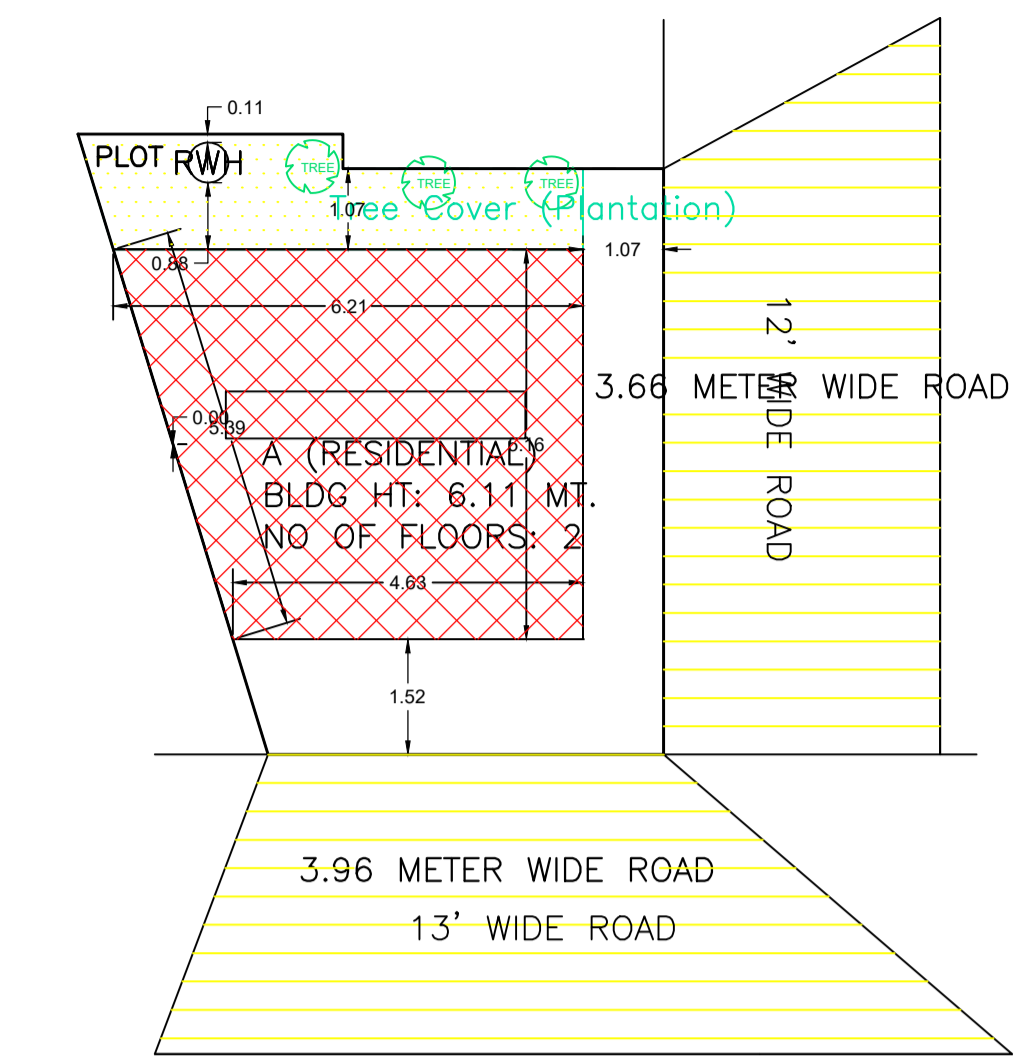

SITE PLAN

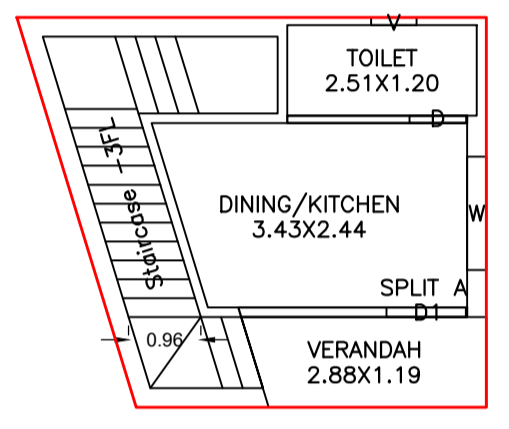

GROUND FLOOR PLAN (Proposed) (SCALE 1:100)

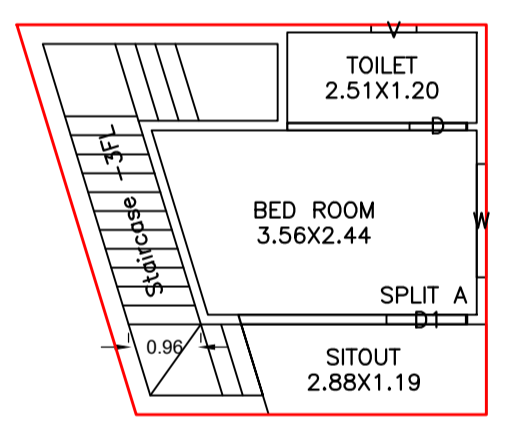

FIRST FLOOR PLAN (Proposed) (SCALE 1:100)

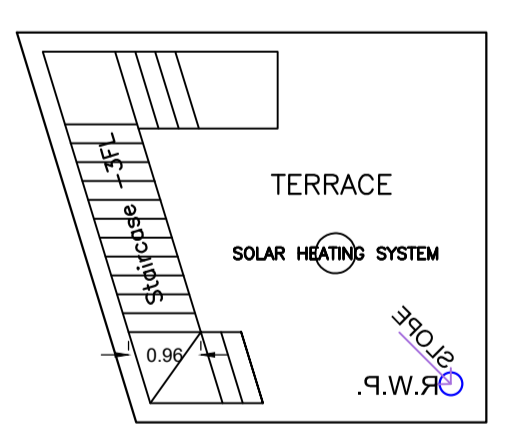

TERRACE FLOOR PLAN (SCALE 1:100)

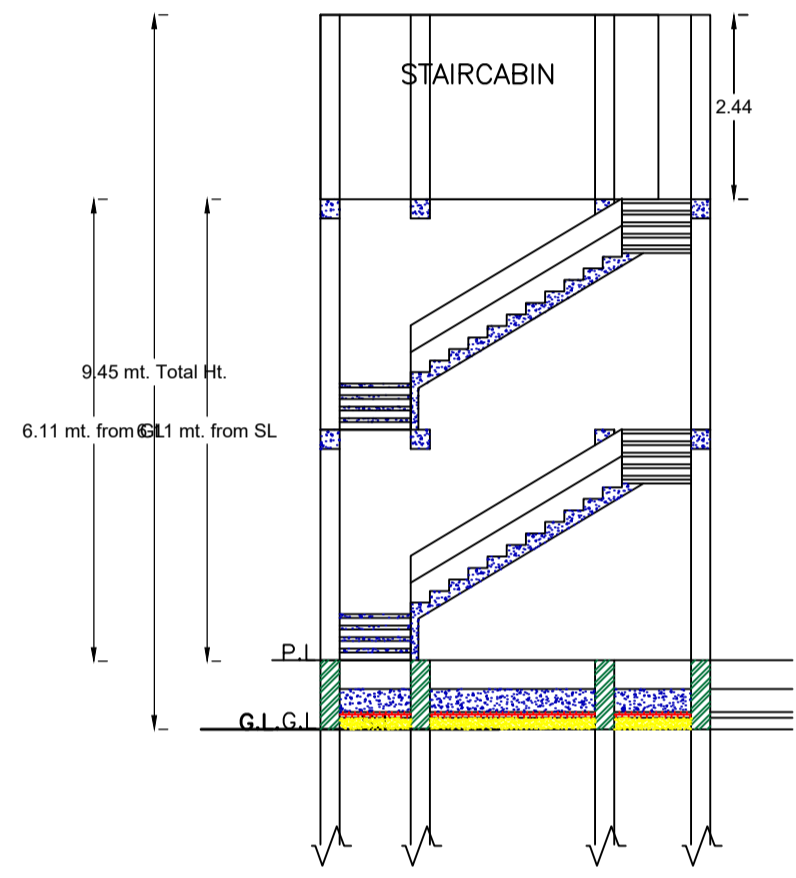

CROSS SECTION (A)

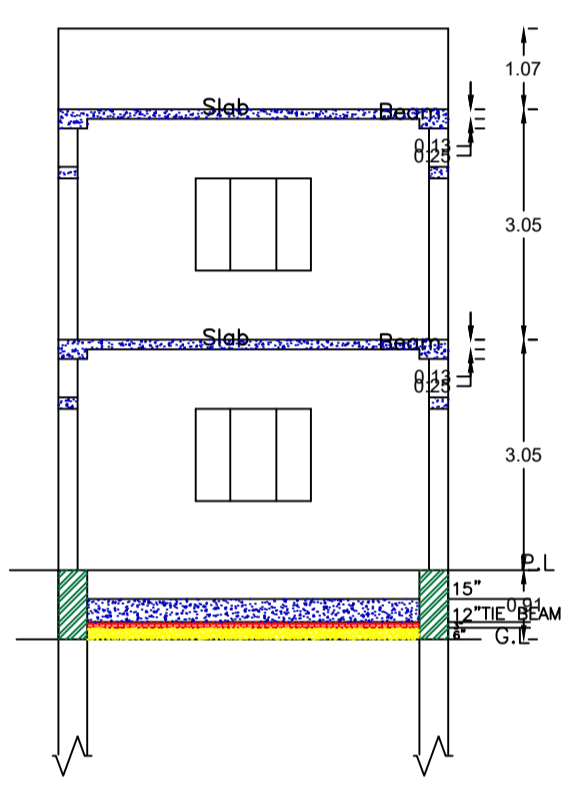

CROSS SECTION (B)

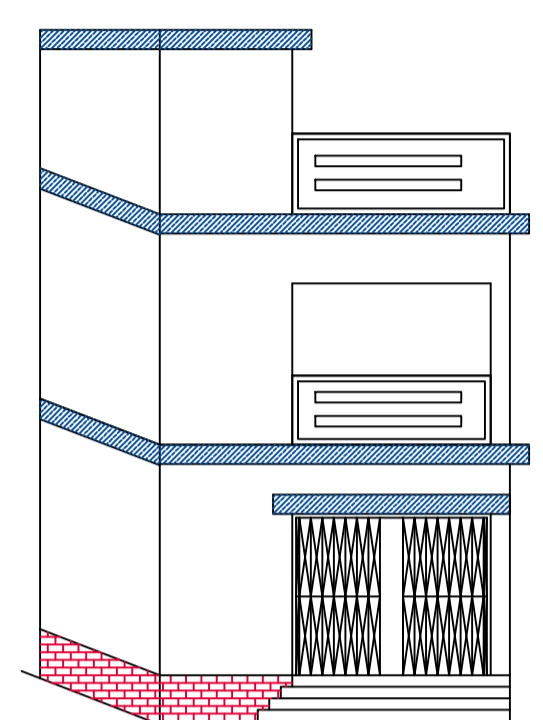
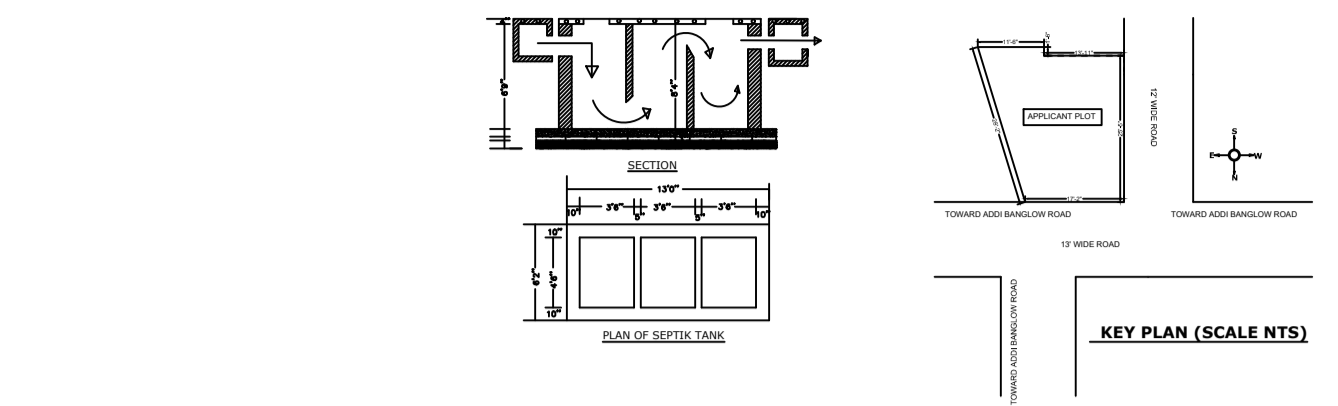

FRONT ELEVATION

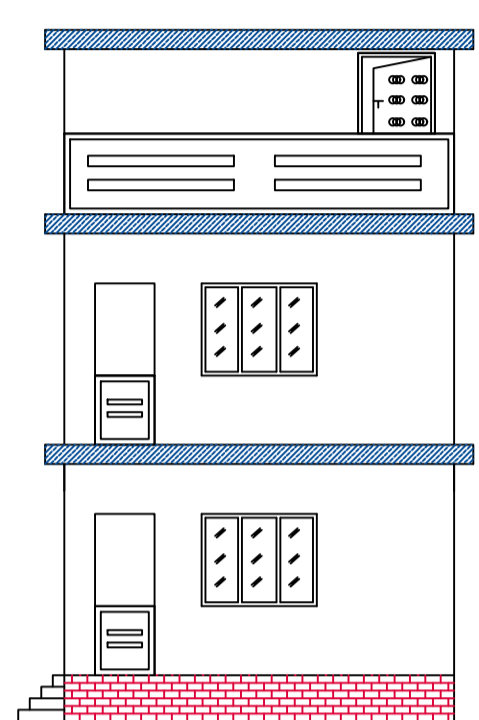

CROSS ELEVATION

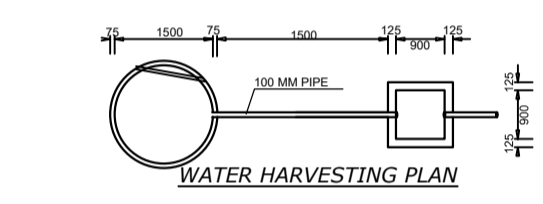

WATER HARVESTING PLAN

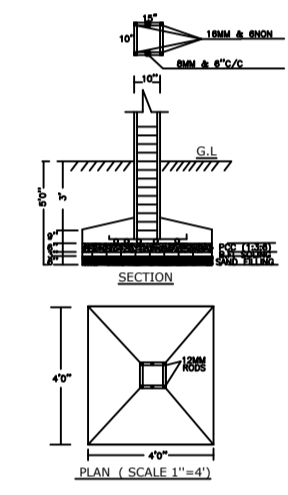
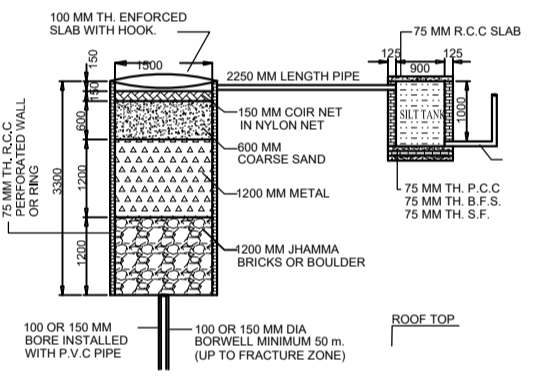

FOUNDATION

AREA STATEMENT JHUMRITILAIYA NAGAR PARISHAD	VERSION NO.: 1.0.70 VERSION DATE: 16/10/2020	SQ.MT.
PROJECT DETAIL: Region: JHARKHAND URBAN LOCAL BODIES District: KODERMA Authority: JHUMRITILAIYA NAGAR PARISHAD	Plot Use: Residential Plot SubUse: Bungalow/ Dwelling / Non Apartment Plot Nearby/Religious Structure: NA	
Inward No: JNP/BP/0042/W14/2024 Application Type: General Proposal Project Type: Building Permission Nature of Development: New	Plot SubPlot No: 7143 North: Road Width - 3.96 South: Plot No. - LAND OF ASHOK SAW East: Plot No. - LAND OF GIRDHARI SONKAR West: Road Width - 3.66	
Location of Development Area: Old Area		
AREA DETAILS:		
AREA OF PLOT (Minimum)	(A)	51.30
NET AREA OF PLOT(Gross Plot Area - Deduction from Gross Plot area)	(A-Deductions)	51.30
Deduction for Balance Plot Area(from Gross Plot Area)		
Common Plot		8.37
Total		8.37
BALANCE AREA OF PLOT(Net Plot Area - Recreational/Amenity space)	(A-Deductions)	42.93
PLOT AREA FOR COVERAGE(Net Plot Area)	(A-Deductions)	51.30
Plot Area for FAR (Net Plot Area + Road Widening Area)	(A-Deductions)	51.30
COVERAGE CHECK		
Permissible Coverage area (70.00 %)		35.91
Proposed Coverage Area (54.51 %)		27.96
Total Prop. Coverage Area (54.51 %)		27.96
Balance coverage area (15.50 %)		7.95
FAR CHECK		
Perm. FAR Area (1.500)		76.95
Total Perm. FAR area		76.95
Residential FAR		55.92
Proposed FAR Area		55.92
Total Proposed FAR Area		55.92
Consumed FAR (Factor)		1.09
Balance FAR Area		21.03
BUILT UP AREA CHECK		
Total Proposed BuiltUp Area		55.92
ARCHITECT (Regd)	KIRAN KUMARI	
ENGINEER (Regd)		
SUPERVISOR (Regd)		
OWNER (Regd)	SMT MUNNI DEVI	
DEVELOPMENT AUTHORITY		LOCAL BODY

COLOR INDEX	
PLOT BOUNDARY	Black
ABUTTING ROAD	Green
PROPOSED CONSTRUCTION	Red
COMMON PLOT	Yellow
ROAD WIDENING AREA	Blue
EXISTING (To be retained)	Light Blue
EXISTING (To be demolished)	Dark Blue

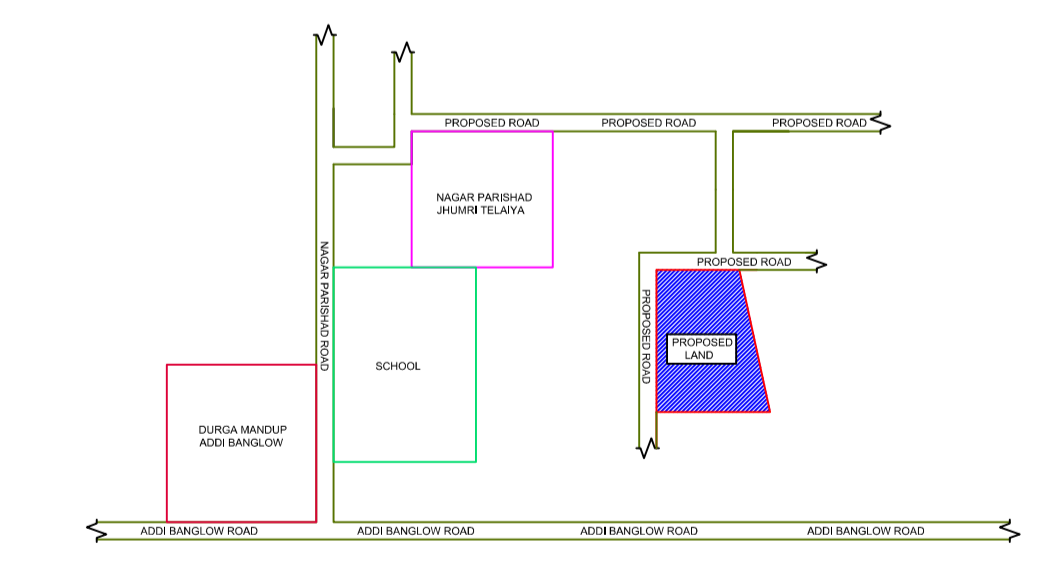

LOCATION PLAN (SCALE -1''32')

Floor Name	Building Name A (RESIDENTIAL)		Total	
	Proposed Built Up Area (Sq.mt.)	Proposed FAR Area (Sq.mt.)	Total Proposed Built Up Area (Sq.mt.)	Total FAR Area (Sq.mt.)
Ground Floor	27.96	27.96	27.96	27.96
First Floor	27.96	27.96	27.96	27.96
Terrace Floor	0.00	0.00	0.00	0.00
Total :	55.92	55.92	55.92	55.92

Building USE/SUBUSE Details			
Building Name	Building Use	Building SubUse	Building Structure
A (RESIDENTIAL)	Residential	Bungalow/ Dwelling / Non Apartment	Non-Highrise

Building :A (RESIDENTIAL)					
Floor Name	Total Built Up Area (Sq.mt.)	Proposed FAR Area (Sq.mt.)	Total FAR Area (Sq.mt.)	Total Consumed Additional FAR Area (Sq.mt.)	Tnmt (No.)
Ground Floor	27.96	27.96	27.96	27.96	01
First Floor	27.96	27.96	27.96	27.96	00
Terrace Floor	0.00	0.00	0.00	0.00	00
Total :	55.92	55.92	55.92	55.92	01
Total Number of Same Buildings	1				
Total :	55.92	55.92	55.92	55.92	01

SCHEDULE OF DOOR:

BUILDING NAME	NAME	LENGTH	HEIGHT	NOS
A (RESIDENTIAL)	D	0.75	2.10	02
A (RESIDENTIAL)	D1	1.05	2.10	02

SCHEDULE OF WINDOW/VENTILATION:

BUILDING NAME	NAME	LENGTH	HEIGHT	NOS
A (RESIDENTIAL)	V	0.80	0.90	02
A (RESIDENTIAL)	W	1.50	1.20	02

UnitBUA Table for Building :A (RESIDENTIAL)

FLOOR	Name	UnitBUA Type	UnitBUA Area	Carpet Area	No. of Rooms	No. of Tenement
FIRST FLOOR PLAN	SPLIT A	FLAT	0.00	0.00	3	0
GROUND FLOOR PLAN	SPLIT A	FLAT	33.44	32.21	3	1
Total:	-	-	33.44	32.21	6	1

LTP NAME AND SIGNATURE	STRUCTURAL ENG'S NAME AND SIGNATURE	BUILDER NAME AND SIGNATURE	DIGITAL SIGNATURE
KIRAN KUMARI JNP/ENG/0001/2019			