

SEC. X-Y  
R.C.C. COLUMN FDN.DETAIL

SCALE 1" = 2'-0"

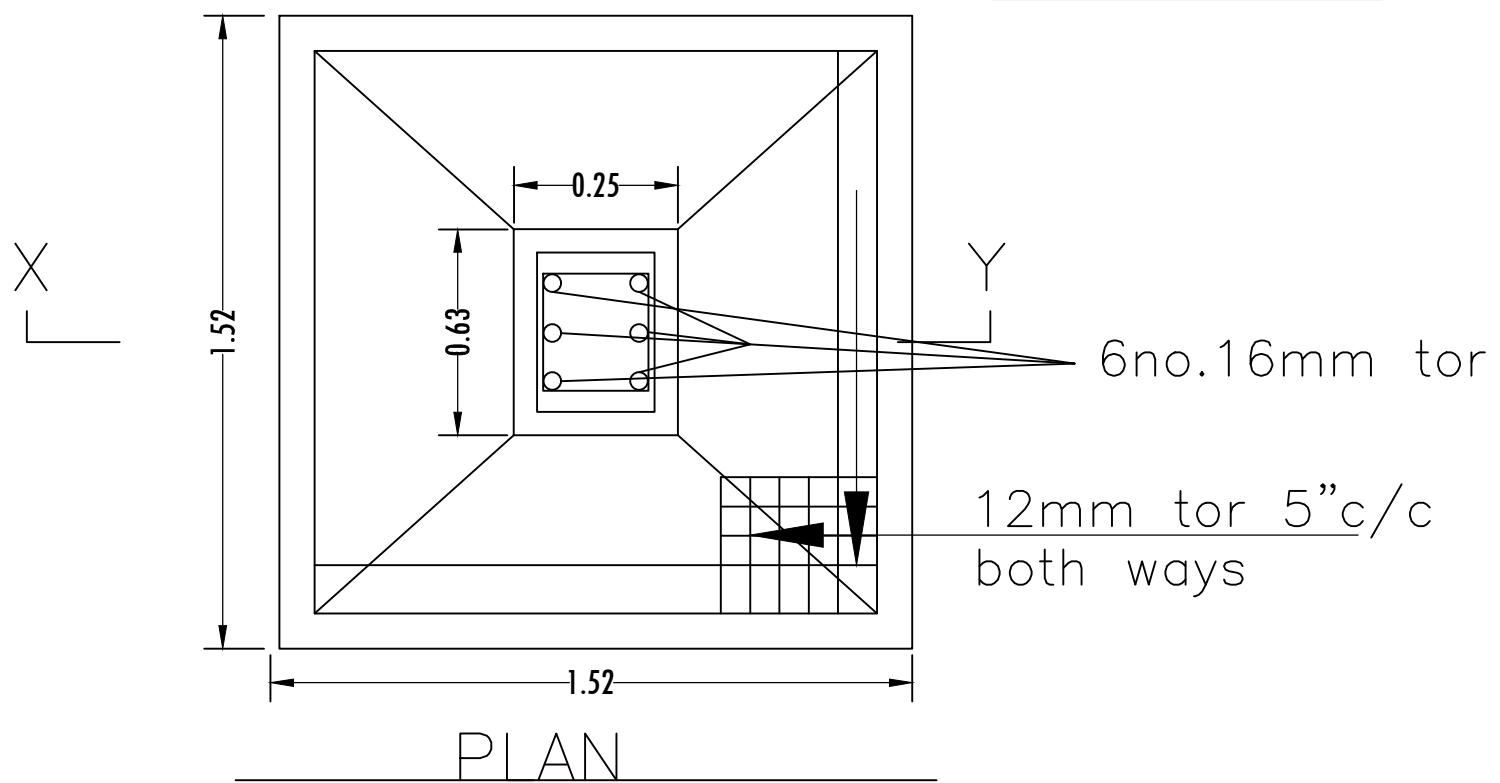

SCALE - 1":2'-0"