

Project Title :SATVINDER KOUR

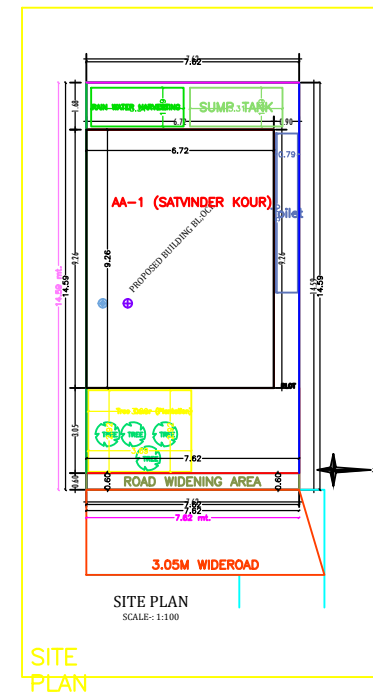
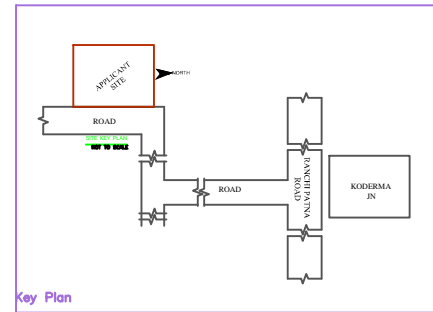
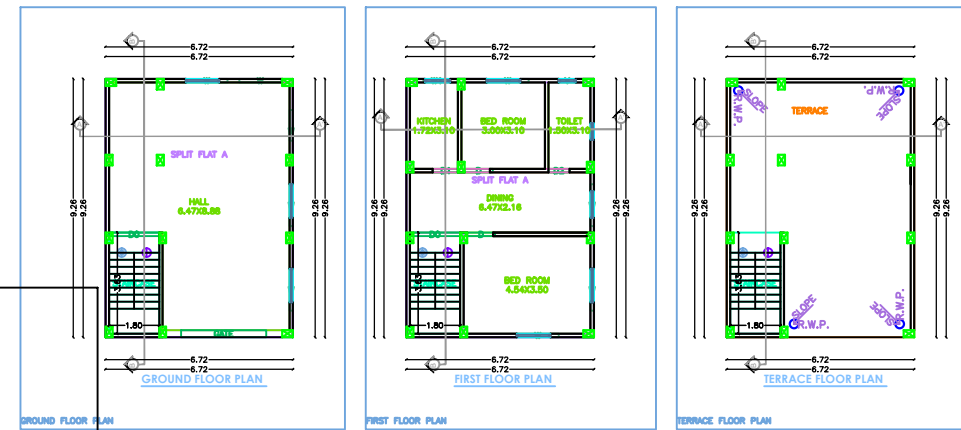
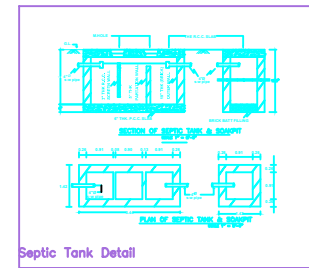
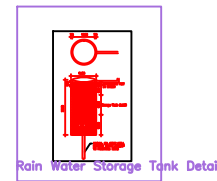
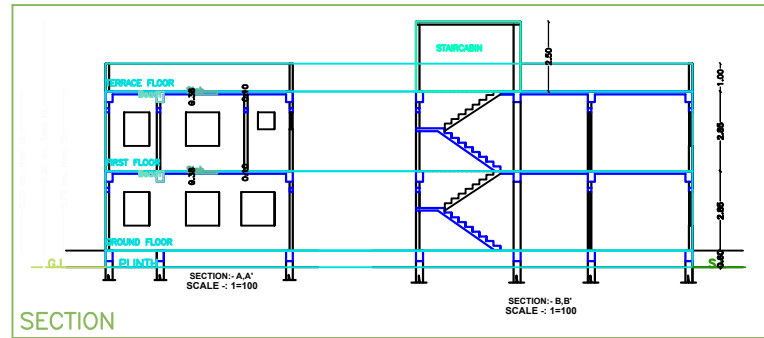
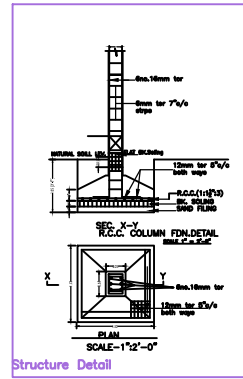
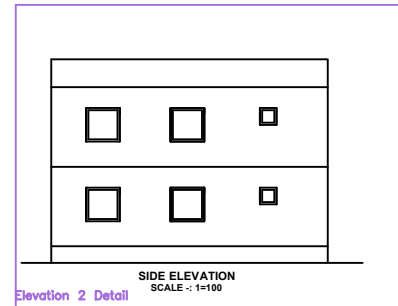
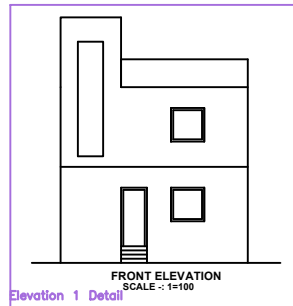

AREA STATEMENT - JHARRILATA NAGAR		VERSION NO. 1.0.37
PARISHAD		VERSION DATE: 16/10/2020
PROJECT DETAIL		
Inward No. :-	Plot Use :- Residential	
Region :- JHARRIAND URBAN LOCAL BODIES	Plot Sub Use :- Bungalow/ Dwelling / Non Apartment	
Town :- KODERMA	Land Use Zone :- RA	
Application Type :- General Proposal	Abutting Road Width :-	
Project Type :- Building Permission	Plot No. :-	
Nature of Development :- New	Revenue Survey No/Survey No :-	
Location :- 1st Area	Tran No :-	
Sub Location :- NA	Holding No :-	
Village/Moza Name :-	Khata No :-	
Ward No :-	North :-	
Road/West :-	South :-	
	East :-	
	West :-	
AREA DETAILS		SQ.MT.
AREA OF PLOT (Minimum)	(A)	111.10
Deduction for Net Plot Area		
Road Widening Area		4.57
Total		106.53
Net Plot Area (Gross Plot Area - Deduction from Gross Plot Area)	(A-Deductions)	106.53
Deductions for Balance Plot Area (from Gross Plot Area)		
Road Widening Area		4.57
COP Area		10.77
Total		15.34
Balance Plot Area (Net Plot Area - Recreational/Amenity space)	(A-Deductions)	95.77
Plot Area for Coverage (Net Plot Area)	(A-Deductions)	106.53
Plot Area for FSI (Net Plot Area + Road Widening Area)	(A-Deductions)	106.53
Access/Use Area		4.52
COVERAGE CHECK		
Proposed Coverage Area (58.38 %)		62.17
Total Coverage Area (58.38 %)		62.17
FAR CHECK		
Proposed Area of FAR		124.34
Total Area of FAR		124.34
BUILT UP AREA CHECK		
Total Proposed Built up Area		124.34
ARCHT/ENGR/SUPERVISOR (Regd)	OWNER	
DEVELOPMENT AUTHORITY LOCAL BODY		

COLOR INDEX	
PLOT BOUNDARY	Black
ABUTTING ROAD	Green
PROPOSED WORK (COVERAGE AREA)	Red
EXISTING (To be retained)	Blue
EXISTING (To be demolished)	Yellow

MARGIN DETAIL					
Building / Wing	Road Name	Front Margin	Rear Margin	Side1 Margin	Side2 Margin
AA-1 (SATVINDER KOUR)	ROAD WIDENING AREA	3.05	1.68	0.90	0.00

FAR & Tenement Details (Table 4c-1)					
Building	No. of Same Bldg	Total Built Up Area (Sq.mt.)	Proposed FAR Area (Sq.mt.)	Total FAR Area (Sq.mt.)	Tent (No.)
AA (SATVINDER KOUR)	1	124.34	124.34	124.34	01
Grand Total	1	124.34	124.34	124.34	01

Building AA (SATVINDER KOUR)				
Floor Name	Total Built Up Area (Sq.mt.)	Proposed FAR Area (Sq.mt.)	Total FAR Area (Sq.mt.)	Tent (No.)
Ground Floor	62.17	62.17	62.17	01
First Floor	62.17	62.17	62.17	00
Terrace Floor	0.00	0.00	0.00	01
Total	124.34	124.34	124.34	01
Total Number of Same Buildings	1			
Total	124.34	124.34	124.34	01

SCHEDULE OF JOINERY:				
BUILDING NAME	NAME	LENGTH	HEIGHT	NOS
AA (SATVINDER KOUR)	D2	0.75	2.10	01
AA (SATVINDER KOUR)	D1	0.90	2.10	01
AA (SATVINDER KOUR)	D	1.00	2.10	02
AA (SATVINDER KOUR)	D0	1.80	2.10	02
AA (SATVINDER KOUR)	GATE	3.05	2.40	01
Total				07

SCHEDULE OF JOINERY:				
BUILDING NAME	NAME	LENGTH	HEIGHT	NOS
AA (SATVINDER KOUR)	V	0.80	1.00	01
AA (SATVINDER KOUR)	W1	0.90	1.20	01
AA (SATVINDER KOUR)	W	1.10	1.20	01
AA (SATVINDER KOUR)	W	1.50	1.20	08
Total				11

UnitBUA Table for Building AA (SATVINDER KOUR)						
FLOOR	Name	UnitBUA Type	UnitBUA Area	Carpet Area	No. of Rooms	No. of Tenement
GROUND FLOOR PLAN	SPLIT FLAT A	FLAT	101.96	101.15	1	1
TERRACE			101.96	101.15	6	1