

Proposal Basic Information

Proposal File No.	JNP/BP/0007/W14/2024
Owner Name	SRI SHASHI BHUSHAN PRASAD
Khata No	1213
Plot No	7164
Village Name	Tilaiya
Use	Residential
SubUse	Bungalow/ Dwelling / Non Apartment

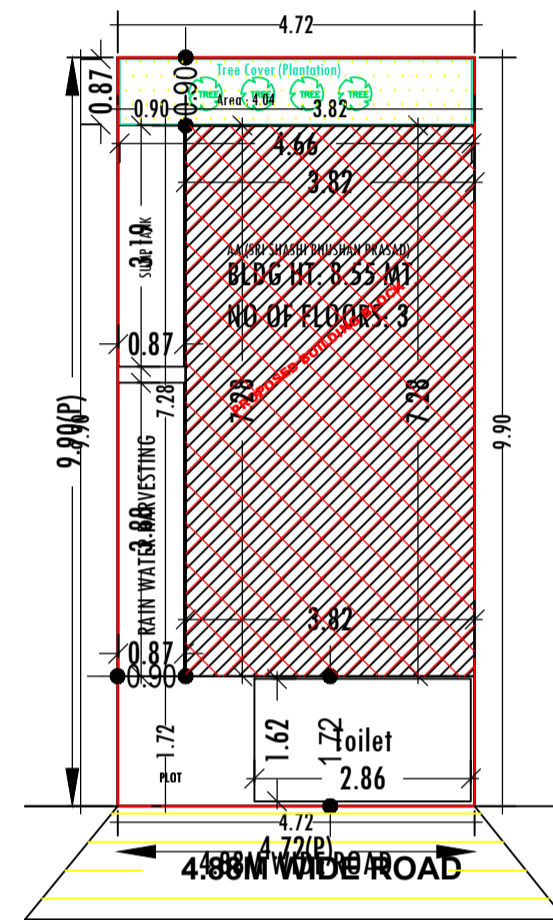

SITE PLAN
SCALE : 1=100

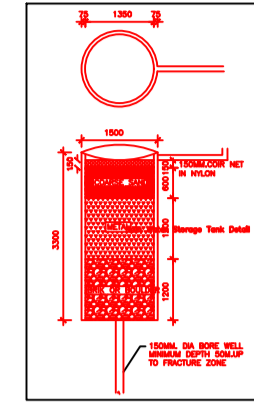
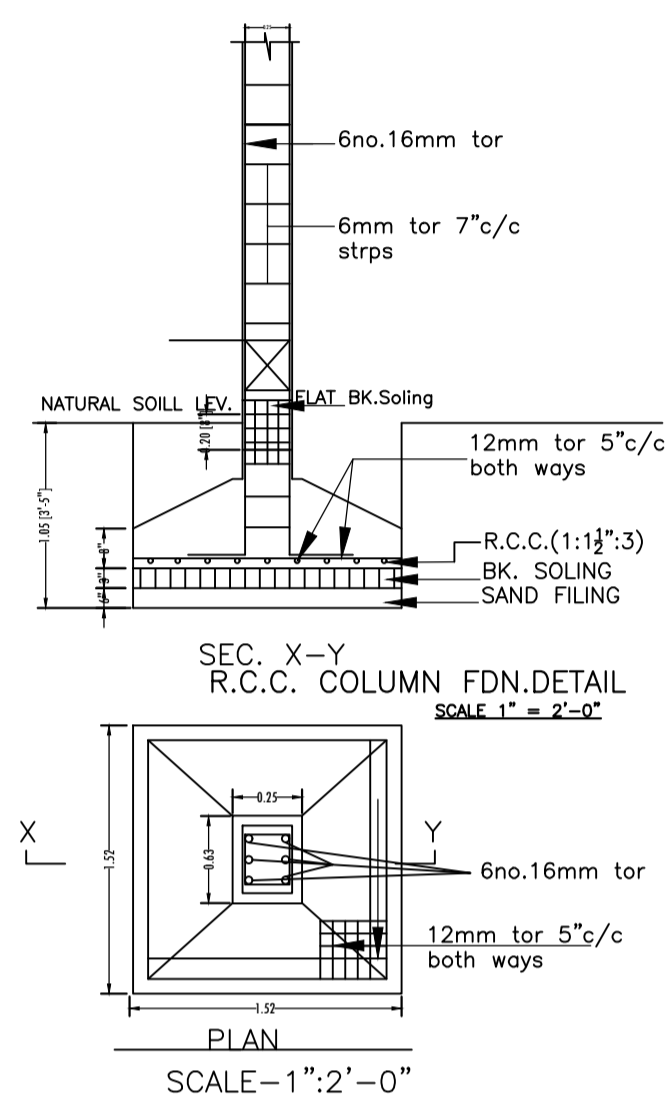

SEC. X-Y
R.C.C. COLUMN FDN.DETAIL
SCALE 1" = 2'-0"

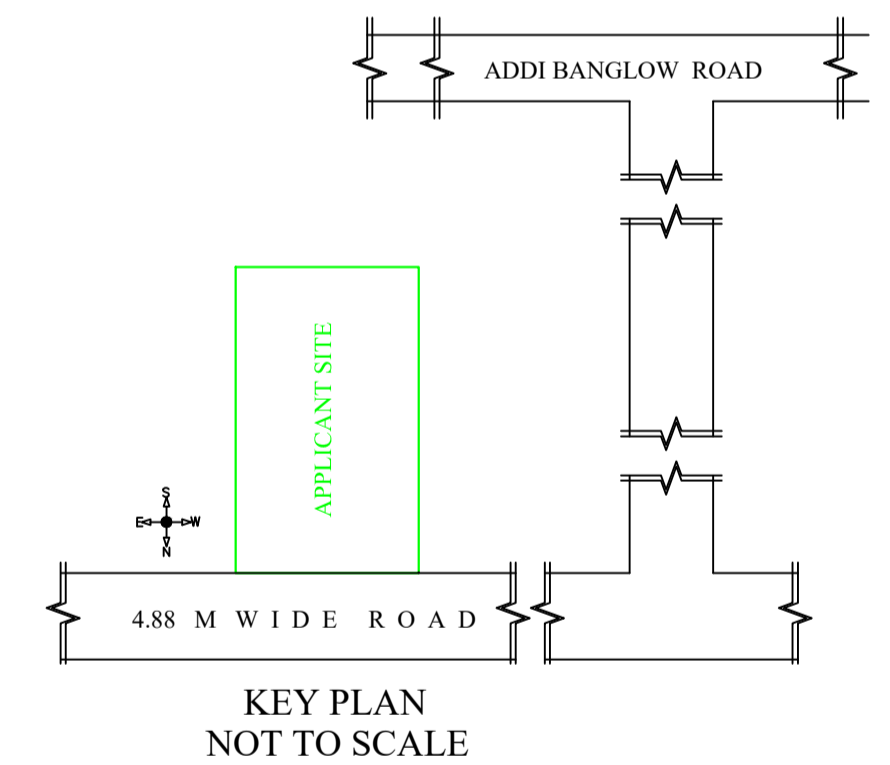

KEY PLAN
NOT TO SCALE

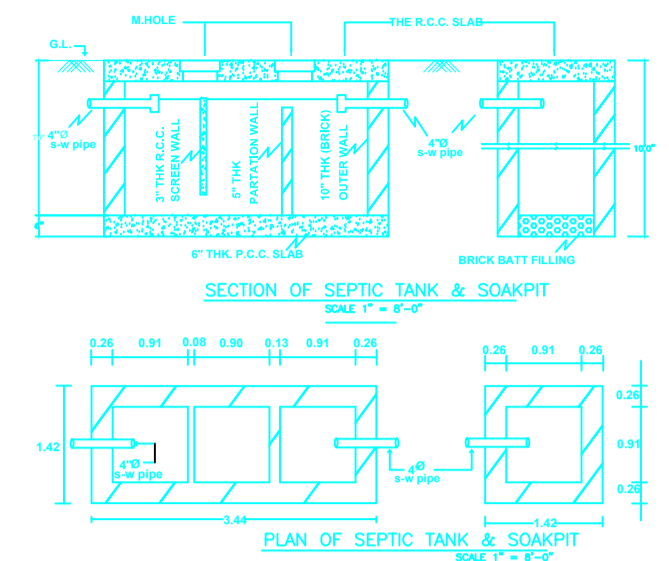

SECTION OF SEPTIC TANK & SOAKPIT
SCALE 1:10

SCHEDULE OF DOOR:

BUILDING NAME	NAME	LENGTH	HEIGHT	NOS
AA (SRI SHASHI BHUSHAN PRASAD)	D2	0.75	2.10	01
AA (SRI SHASHI BHUSHAN PRASAD)	D1	0.90	2.10	01
AA (SRI SHASHI BHUSHAN PRASAD)	D	1.00	2.10	03

SCHEDULE OF WINDOW/VENTILATION:

BUILDING NAME	NAME	LENGTH	HEIGHT	NOS
AA (SRI SHASHI BHUSHAN PRASAD)	V	0.60	0.60	01
AA (SRI SHASHI BHUSHAN PRASAD)	W1	0.90	1.20	01
AA (SRI SHASHI BHUSHAN PRASAD)	W	1.50	1.20	05

Building :AA (SRI SHASHI BHUSHAN PRASAD)

Floor Name	Total Built Up Area (Sq.mt.)	Deductions (Area in Sq.mt.)	Proposed FAR Area (Sq.mt.)	Total FAR Area (Sq.mt.)	Total Consumed Additional FAR Area (Sq.mt.)	Tnmt (No.)
Ground Floor	27.84	0.00	27.84	27.84	27.84	01
First Floor	27.84	0.00	27.84	27.84	27.84	00
Second Floor	27.84	0.90	26.94	26.94	26.94	00
Terrace Floor	0.00	0.00	0.00	0.00	0.00	00
Total :	83.52	0.90	82.62	82.62	82.62	01
Total Number of Same Buildings :	1					
Total :	83.52	0.90	82.62	82.62	82.62	01

FAR & Tenement Details (Table 4c-1)

Building	No. of Same Bldg	Total Built Up Area (Sq.mt.)	Deductions (Area in Sq.mt.)	Proposed FAR Area (Sq.mt.)	Total FAR Area (Sq.mt.)	Total Consumed Additional FAR Area (Sq.mt.)	Tnmt (No.)
AA (SRI SHASHI BHUSHAN PRASAD)	1	83.52	0.90	82.62	82.62	82.62	01
Grand Total :	1	83.52	0.90	82.62	82.62	82.62	01

Building USE/SUBUSE Details

Building Name	Building Use	Building SubUse	Building Structure
AA (SRI SHASHI BHUSHAN PRASAD)	Residential	Bungalow/ Dwelling / Non Apartment	Non-Highrise

Buildingwise Floor FAR Details

Floor Name	Building Name		Total	
	Proposed Built Up Area (Sq.mt.)	Proposed FAR Area (Sq.mt.)	Total Proposed Built Up Area (Sq.mt.)	Total FAR Area (Sq.mt.)
Ground Floor	27.84	27.84	27.84	27.84
First Floor	27.84	27.84	27.84	27.84
Second Floor	27.84	26.94	27.84	26.94
Terrace Floor	0.00	0.00	0.00	0.00
Total :	83.52	82.62	83.52	82.62

COLOR INDEX

PLOT BOUNDARY	Black
ABUTTING ROAD	Green
PROPOSED CONSTRUCTION	Red
COMMON PLOT	Yellow
ROAD WIDENING AREA	Blue
EXISTING (To be retained)	Blue
EXISTING (To be demolished)	Yellow

AREA STATEMENT		VERSION NO. : 1.0.68
JHUMRITILAIYA NAGAR PARISHAD		VERSION DATE: 16/10/2020
PROJECT DETAIL:		
Region: JHARKHAND URBAN LOCAL BODIES	Plot Use: Residential	
District: KODERMA	Plot SubUse: Bungalow/ Dwelling / Non Apartment	
Authority: JHUMRITILAIYA NAGAR PARISHAD	Plot/Nearby/Religious Structure: NA	
Inward_No: JNP/BP/0007/W14/2024	Plot/SubPlot No: 7164	
Application Type: General Proposal	North: Road Width - 4.88M WIDE ROAD	
Project Type: Building Permission	South: Plot No. - SRI NAWAL KISHOR DARUKA	
Nature of Development: New	East: Plot No. - SRI SANJAY SHARMA	
Location of Development Area: Old Area	West: Plot No. - SRI RAJU KUMAR	
AREA DETAILS:		
AREA OF PLOT (Minimum)	(A)	SQ.MT. 46.77
NET AREA OF PLOT(Gross Plot Area - Deduction from Gross Plot area)	(A-Deductions)	46.77
Deduction for Balance Plot Area(from Gross Plot Area)		
Common Plot		4.04
Total		4.04
BALANCE AREA OF PLOT(Net Plot Area - Recreational/Amenity space)	(A-Deductions)	42.73
PLOT AREA FOR COVERAGE(Net Plot Area)	(A-Deductions)	46.77
Plot Area for FAR (Net Plot Area - Road/Widening Area)	(A-Deductions)	46.77
COVERAGE CHECK		
Permissible Coverage area (70.00 %)		32.74
Proposed Coverage Area (59.53 %)		27.84
Total Prop. Coverage Area (59.53 %)		27.84
Balance coverage area (10.48 %)		4.90
FAR CHECK		
Perm. FAR Area (1.800)		84.19
Total Perm. FAR area		84.19
Residential FAR		82.62
Proposed FAR Area		82.62
Total Proposed FAR Area		82.62
Consumed FAR (Factor)		1.77
Balance FAR Area		1.57
BUILT UP AREA CHECK		
Total Proposed BuiltUp Area		83.52
ARCHITECT (Regd)	MD SHOAB ALAM	
ENGINEER (Regd)		
SUPERVISOR (Regd)		
OWNER (Regd)	SRI SHASHI BHUSHAN PRASAD	
DEVELOPMENT AUTHORITY		LOCAL BODY

LTP NAME AND SIGNATURE	STRUCTURAL ENG'S NAME AND SIGNATURE	BUILDER NAME AND SIGNATURE	DIGITAL SIGNATURE
MD SHOAB ALAM JNP/ENG/0001/2017			

Proposal Basic Information

Proposal File No.	JNP/BP/0007/W14/2024
Owner Name	SRI SHASHI BHUSHAN PRASAD
Khata No	1213
Plot No	7164
Village Name	Tilaiya
Use	Residential
SubUse	Bungalow/ Dwelling / Non Apartment



UnitBUA Table for Building :AA (SRI SHASHI BHUSHAN PRASAD)

FLOOR	Name	UnitBUA Type	UnitBUA Area	Carpet Area	No. of Rooms	No. of Tenement
GROUND FLOOR PLAN	SPLIT FLAT A	FLAT	51.17	50.66	1	1
FIRST FLOOR PLAN	SPLIT FLAT A	FLAT	0.00	0.00	1	0
SECOND FLOOR PLAN	SPLIT FLAT A	FLAT	0.00	0.00	3	0
Total	-	-	51.17	50.66	5	1

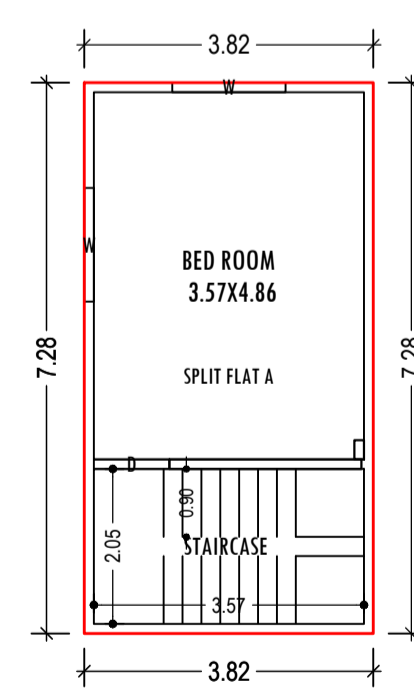

GROUND FLOOR PLAN
(Proposed)
(SCALE 1:100)

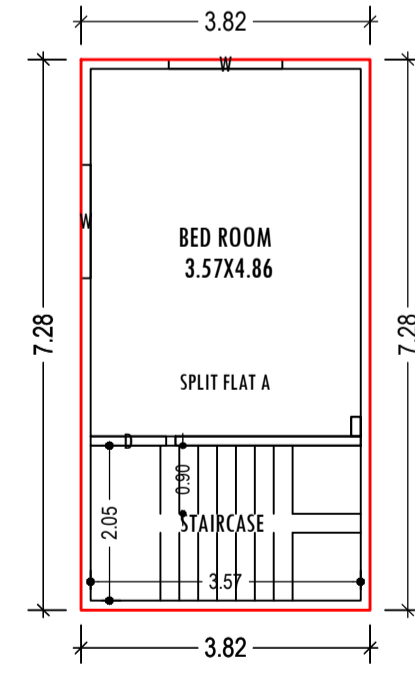

FIRST FLOOR PLAN
(Proposed)
(SCALE 1:100)

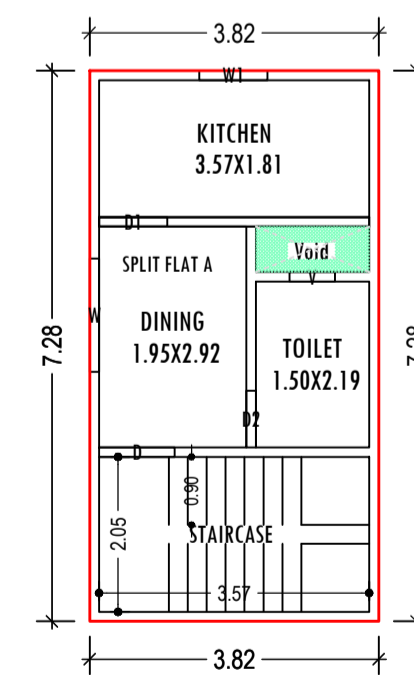

SECOND FLOOR PLAN
(Proposed)
(SCALE 1:100)

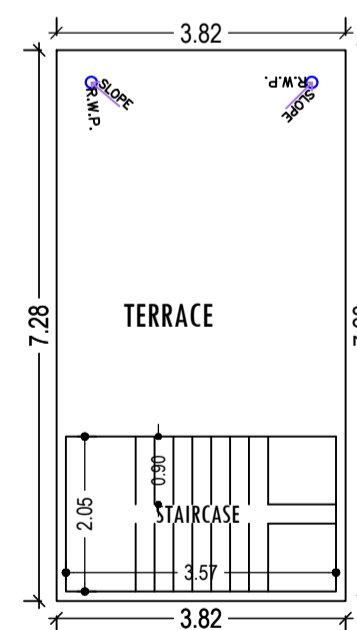

TERRACE FLOOR PLAN
(Proposed)
(SCALE 1:100)

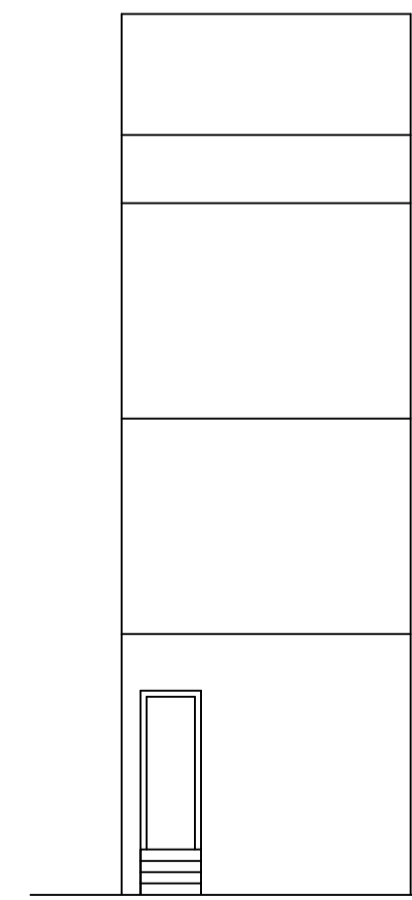

FRONT ELEVATION
SCALE: 1:100

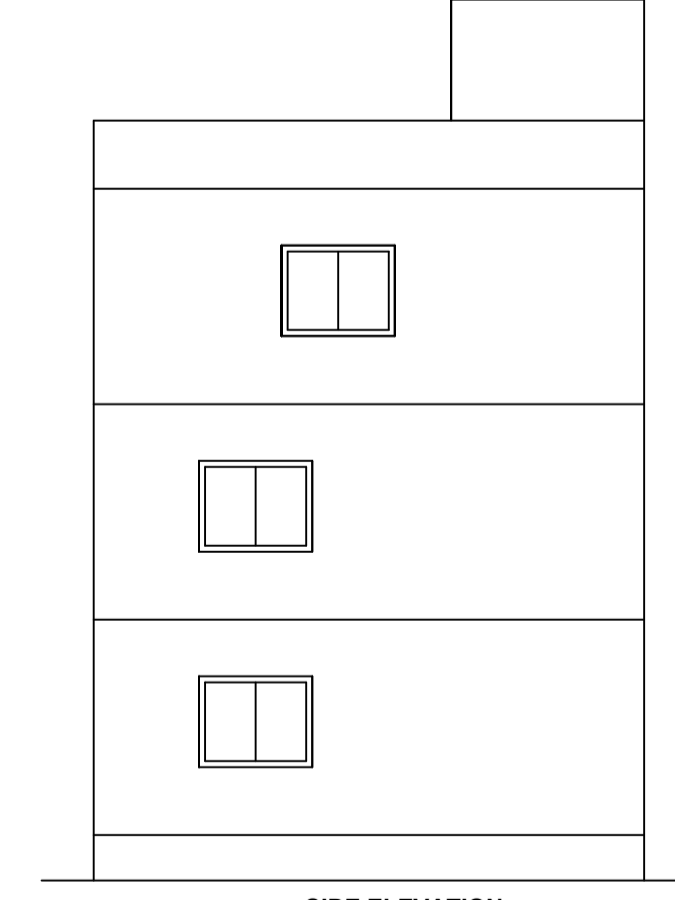

SIDE ELEVATION
SCALE: 1:100

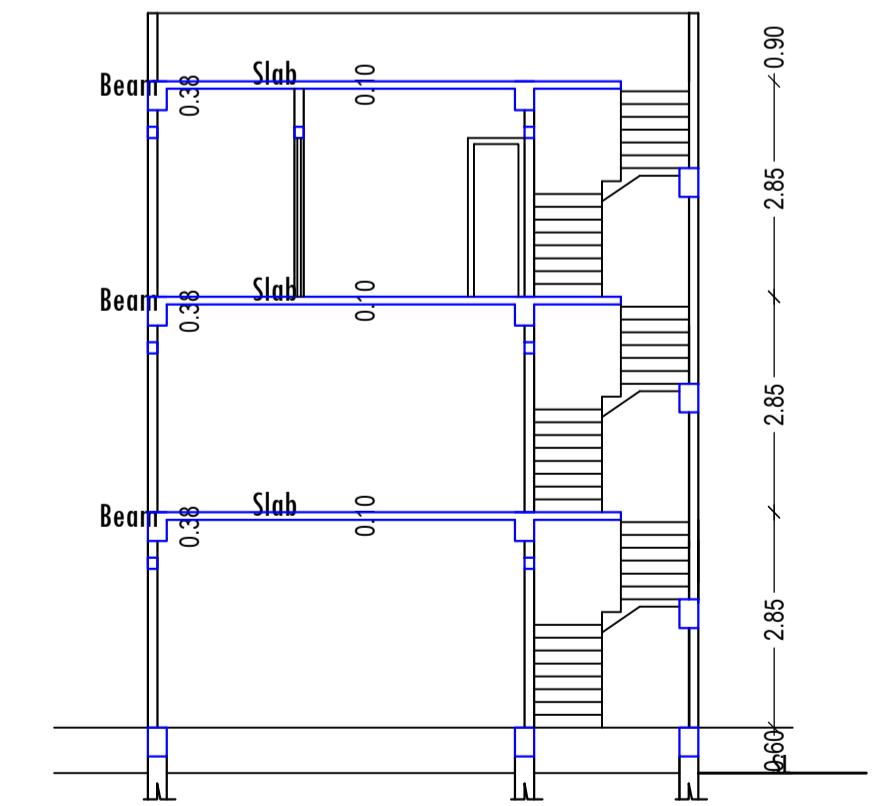
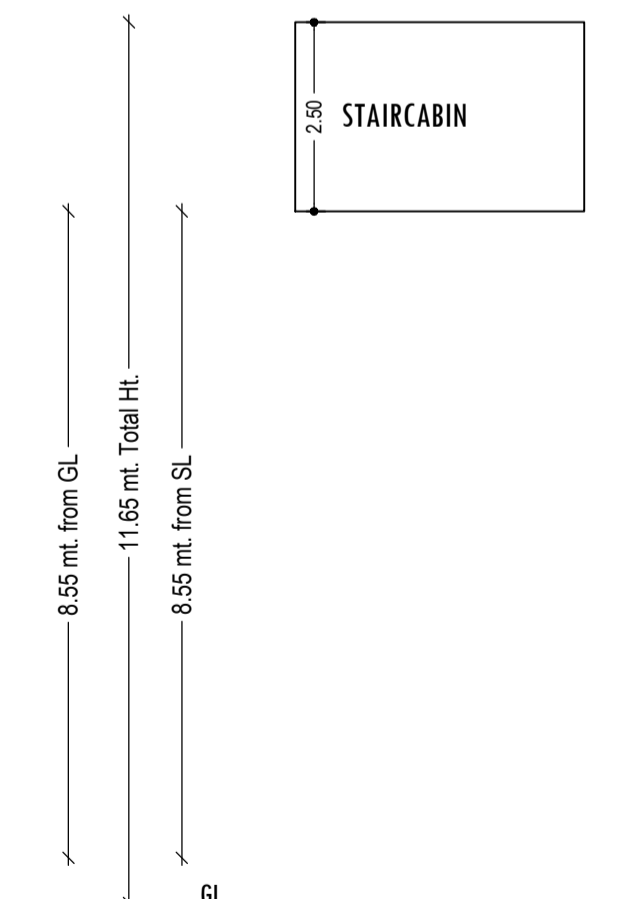

SECTION--YY
SCALE: 1:100

LTP NAME AND SIGNATURE	STRUCTURAL ENG'S NAME AND SIGNATURE	BUILDER NAME AND SIGNATURE	DIGITAL SIGNATURE
MD SHOAB ALAM JNP/ENG/0001/2017			