

**SITE PLAN**  
SCALE :- 1=100

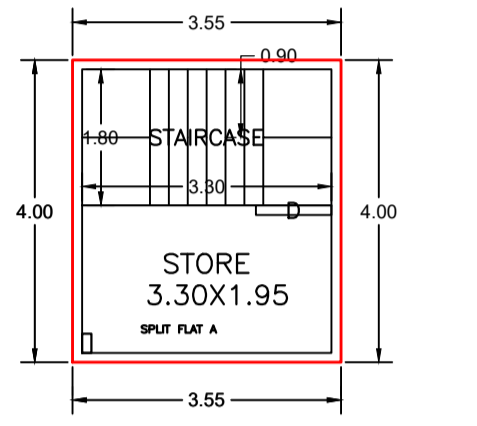

**BASEMENT FLOOR PLAN**  
(Proposed)  
(SCALE 1:100)

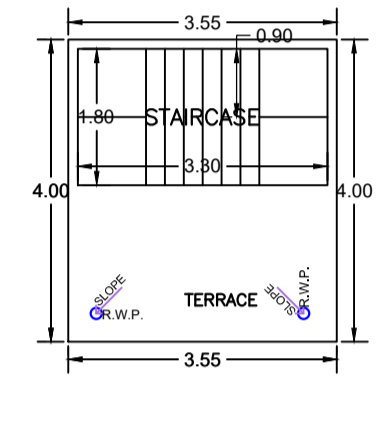

**TERRACE FLOOR PLAN**  
(SCALE 1:100)

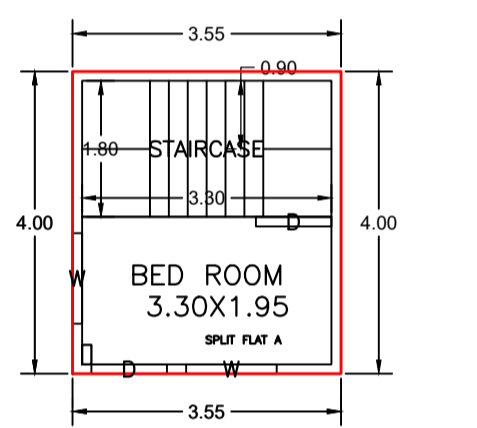

**GROUND FLOOR PLAN**  
(Proposed)  
(SCALE 1:100)

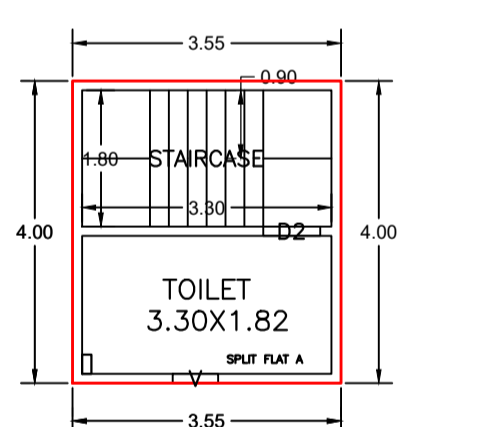

**FIRST FLOOR PLAN**  
(Proposed)  
(SCALE 1:100)

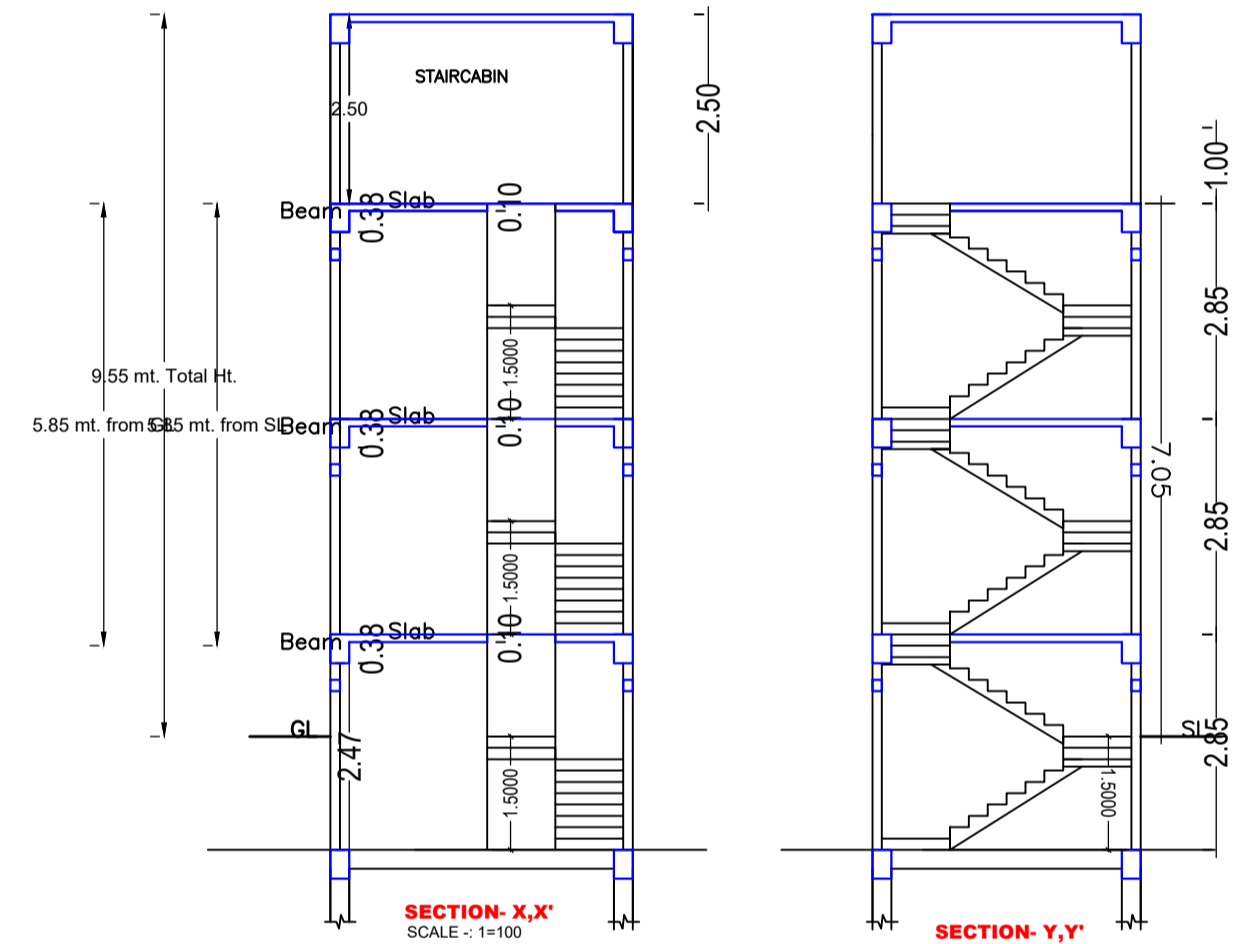

**SECTION - X-X'**  
SCALE :- 1=100

**SECTION - Y-Y'**  
SCALE :- 1=100

**FAR & Tenement Details (Table 4c-1)**

Building	No. of Same Bldg	Total Built Up Area (Sq.mt.)	Proposed FAR Area (Sq.mt.) Resi.	Total FAR Area (Sq.mt.)	Total Consumed Additional FAR Area (Sq.mt.)	Tnmt (No.)
AA (SRI SANTOSH KUMAR)	1	42.60	42.60	42.60	42.60	01
<b>Grand Total :</b>	<b>1</b>	<b>42.60</b>	<b>42.60</b>	<b>42.60</b>	<b>42.60</b>	<b>01</b>

**Proposal Basic Information**

Proposal File No.	JNP/BP/0066/W10/2024
Owner Name	SRI SANTOSH KUMAR
Khata No	631
Plot No	7457
Village Name	Tilaiya
Use	Residential
SubUse	Bungalow/ Dwelling / Non Apartment

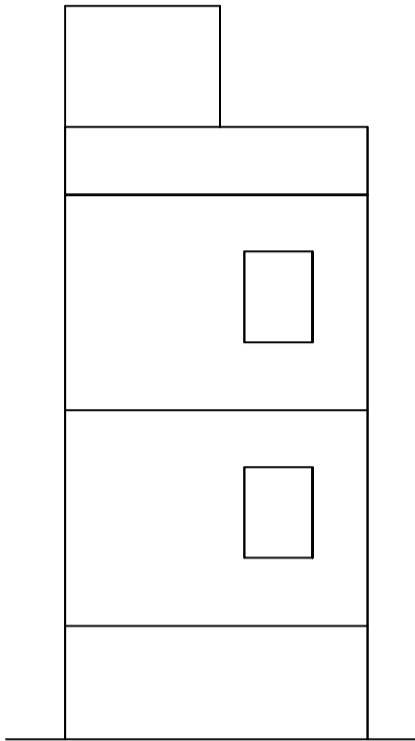
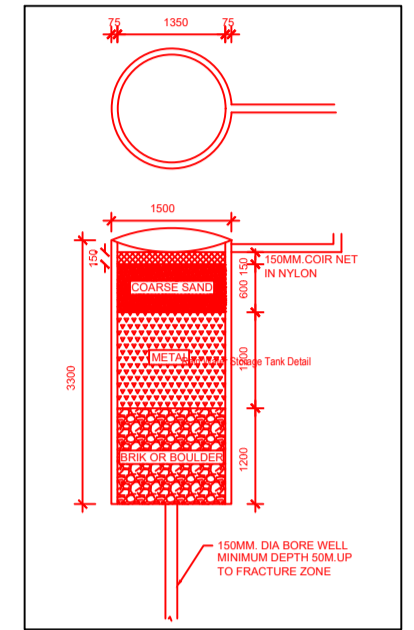

**SIDE ELEVATION**  
SCALE :- 1=100

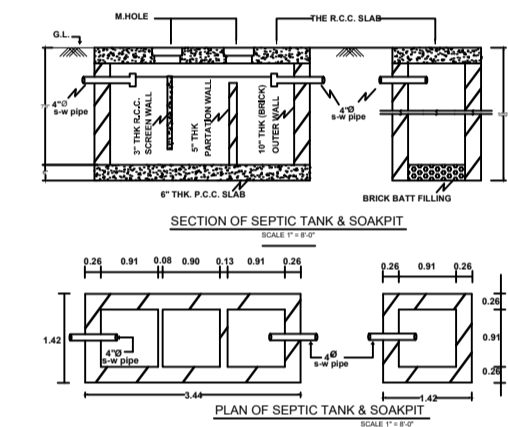

**SECTION OF SEPTIC TANK & SOAKPIT**

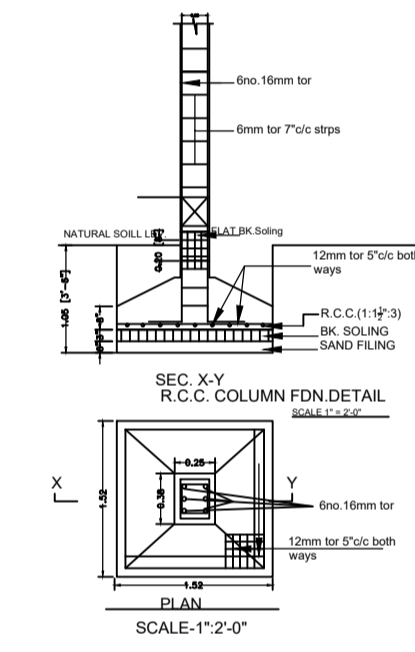

**SEC. X-Y R.C.C. COLUMN FDN.DETAIL**

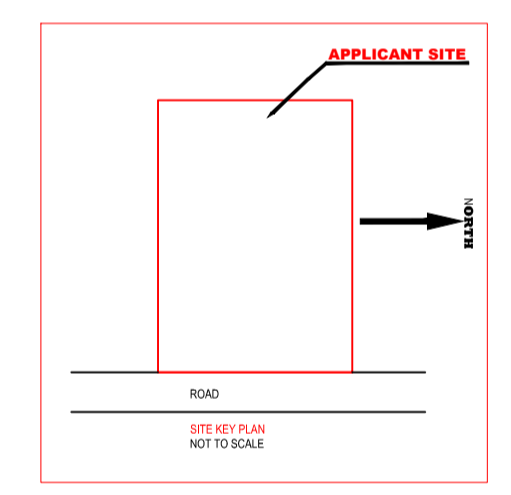

**APPLICANT SITE**  
SCALE :- 1=100

AREA STATEMENT	JHUMRITILAIYA NAGAR PARISHAD	VERSION NO. : 1.0.70	VERSION DATE: 16/10/2020
PROJECT DETAIL:	Region: JHARKHAND URBAN LOCAL BODIES	Plot Use: Residential	
	District: KODERMA	Plot SubUse: Bungalow/ Dwelling / Non Apartment	
	Authority: JHUMRITILAIYA NAGAR PARISHAD	PlotNearbyReligiousStructure: NA	
	Inward No: JNP/BP/0066/W10/2024	Plot/SubPlot No: 7457	
	Application Type: General Proposal	North: Plot No. - LAND OF SUSHIL KUMAR CHHABRA	
	Project Type: Building Permission	South: Plot No. - LAND OF BINOD KUMAR	
	Nature of Development: New	East: Road Width - 4.57M WIDE ROAD	
	Location of Development Area: Old Area	West: Plot No. - OWN LAND OF VENDER & SUSHIL KUMAR CHHABRA	
AREA DETAILS:			SQ. MT.
AREA OF PLOT (Minimum)	(A)		29.25
NET AREA OF PLOT(Gross Plot Area - Deduction from Gross Plot area)	(A-Deductions)		29.25
Deduction for Balance Plot Area(from Gross Plot Area)			
Common Plot			1.89
Total			1.89
BALANCE AREA OF PLOT(Net Plot Area - Recreational/Amenity space)	(A-Deductions)		27.36
PLOT AREA FOR COVERAGE(Net Plot Area)	(A-Deductions)		29.25
Plot Area for FAR (Net Plot Area + Road Widening Area)	(A-Deductions)		29.25
COVERAGE CHECK			
Permissible Coverage area ( 70.00 % )			20.48
Proposed Coverage Area ( 48.55 % )			14.20
Total Prop. Coverage Area ( 48.55 % )			14.20
Balance coverage area ( 21.47 % )			6.28
FAR CHECK			
Perm. FAR Area ( 1.500 )			43.88
Total Perm. FAR area			43.88
Residential FAR			42.59
Proposed FAR Area			42.59
Total Proposed FAR Area			42.59
Consumed FAR (Factor)			1.46
Balance FAR Area			1.29
BUILT UP AREA CHECK			
Total Proposed BuiltUp Area			42.60
ARCHITECT (Regd)			MD SHOAB ALAM
ENGINEER (Regd)			
SUPERVISOR (Regd)			
OWNER (Regd)			SRI SANTOSH KUMAR
DEVELOPMENT AUTHORITY			LOCAL BODY

COLOR INDEX	
PLOT BOUNDARY	Black
ABUTTING ROAD	Green
PROPOSED CONSTRUCTION	Red
COMMON PLOT	Yellow
ROAD WIDENING AREA	Blue
EXISTING (To be retained)	Blue
EXISTING (To be demolished)	Yellow

**Buildingwise Floor FAR Details**

Floor Name	Building Name		Total	
	Proposed Built Up Area (Sq.mt.)	Proposed FAR Area (Sq.mt.)	Total Proposed Built Up Area (Sq.mt.)	Total FAR Area (Sq.mt.)
Basement Floor	14.20	14.20	14.20	14.20
Ground Floor	14.20	14.20	14.20	14.20
First Floor	14.20	14.20	14.20	14.20
Terrace Floor	0.00	0.00	0.00	0.00
<b>Total :</b>	<b>42.60</b>	<b>42.60</b>	<b>42.60</b>	<b>42.60</b>

**Building USE/SUBUSE Details**

Building Name	Building Use	Building SubUse	Building Structure
AA (SRI SANTOSH KUMAR)	Residential	Bungalow/ Dwelling / Non Apartment	Non-Highrise

**Building :AA (SRI SANTOSH KUMAR)**

Floor Name	Total Built Up Area (Sq.mt.)	Proposed FAR Area (Sq.mt.) Resi.	Total FAR Area (Sq.mt.)	Total Consumed Additional FAR Area (Sq.mt.)	Tnmt (No.)
Basement Floor	14.20	14.20	14.20	14.20	01
Ground Floor	14.20	14.20	14.20	14.20	00
First Floor	14.20	14.20	14.20	14.20	00
Terrace Floor	0.00	0.00	0.00	0.00	00
<b>Total :</b>	<b>42.60</b>	<b>42.60</b>	<b>42.60</b>	<b>42.60</b>	<b>01</b>
<b>Total Number of Same Buildings :</b>	<b>1</b>				
<b>Total :</b>	<b>42.60</b>	<b>42.60</b>	<b>42.60</b>	<b>42.60</b>	<b>01</b>

**SCHEDULE OF DOOR:**

BUILDING NAME	NAME	LENGTH	HEIGHT	NOS
AA (SRI SANTOSH KUMAR)	D2	0.75	2.10	01
AA (SRI SANTOSH KUMAR)	D	1.00	2.10	03

**SCHEDULE OF WINDOW/VENTILATION:**

BUILDING NAME	NAME	LENGTH	HEIGHT	NOS
AA (SRI SANTOSH KUMAR)	V	0.60	0.60	01
AA (SRI SANTOSH KUMAR)	W	1.20	1.20	02

**UnitBUA Table for Building :AA (SRI SANTOSH KUMAR)**

FLOOR	Name	UnitBUA Type	UnitBUA Area	Carpet Area	No. of Rooms	No. of Tenement
BASEMENT FLOOR PLAN	SPLIT FLAT A	FLAT	19.30	19.20	1	1
GROUND FLOOR PLAN	SPLIT FLAT A	FLAT	0.00	0.00	1	0
FIRST FLOOR PLAN	SPLIT FLAT A	FLAT	0.00	0.00	1	0
<b>Total:</b>	-	-	<b>19.30</b>	<b>19.20</b>	<b>3</b>	<b>1</b>

LTP NAME AND SIGNATURE	STRUCTURAL ENG'S NAME AND SIGNATURE	BUILDER NAME AND SIGNATURE	DIGITAL SIGNATURE
MD SHOAB ALAM JNP/ENG/0001/2017			