

SITE PLAN
SCALE :- 1=100

SITE PLAN

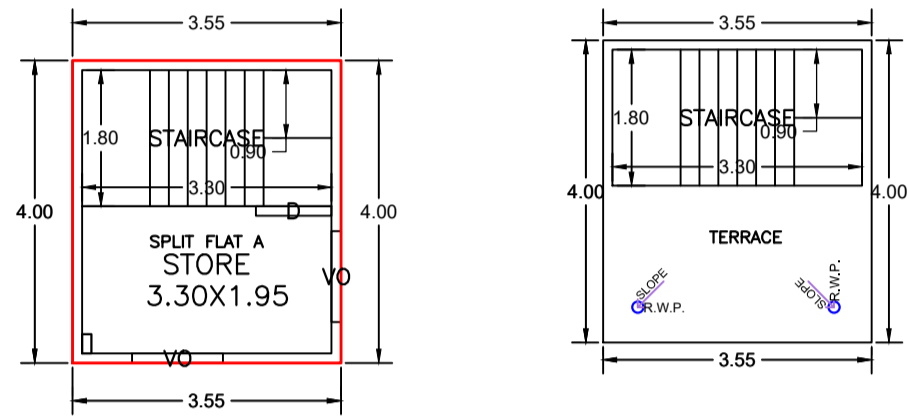

BASEMENT FLOOR PLAN
(Proposed)
(SCALE 1:100)

TERRACE FLOOR PLAN
(SCALE 1:100)

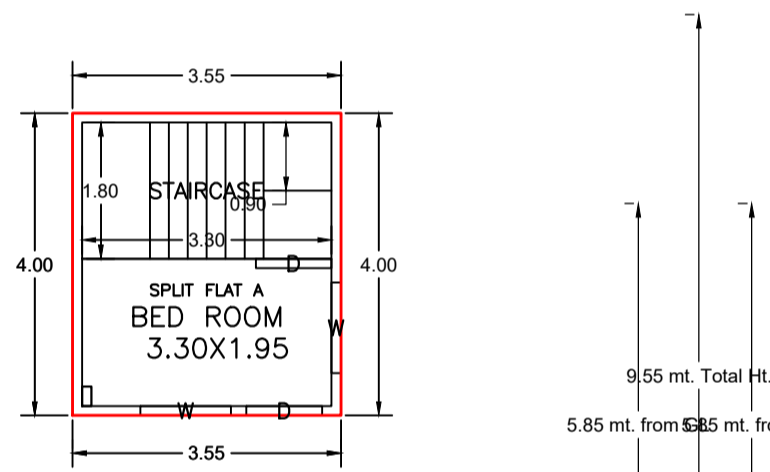

GROUND FLOOR PLAN
(Proposed)
(SCALE 1:100)

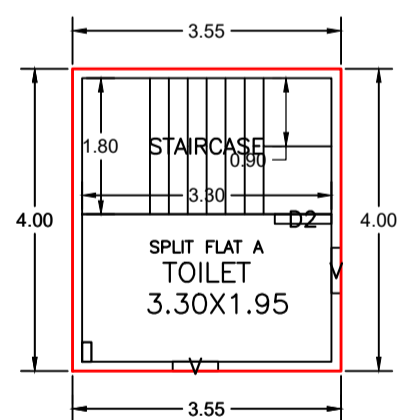

FIRST FLOOR PLAN
(Proposed)
(SCALE 1:100)

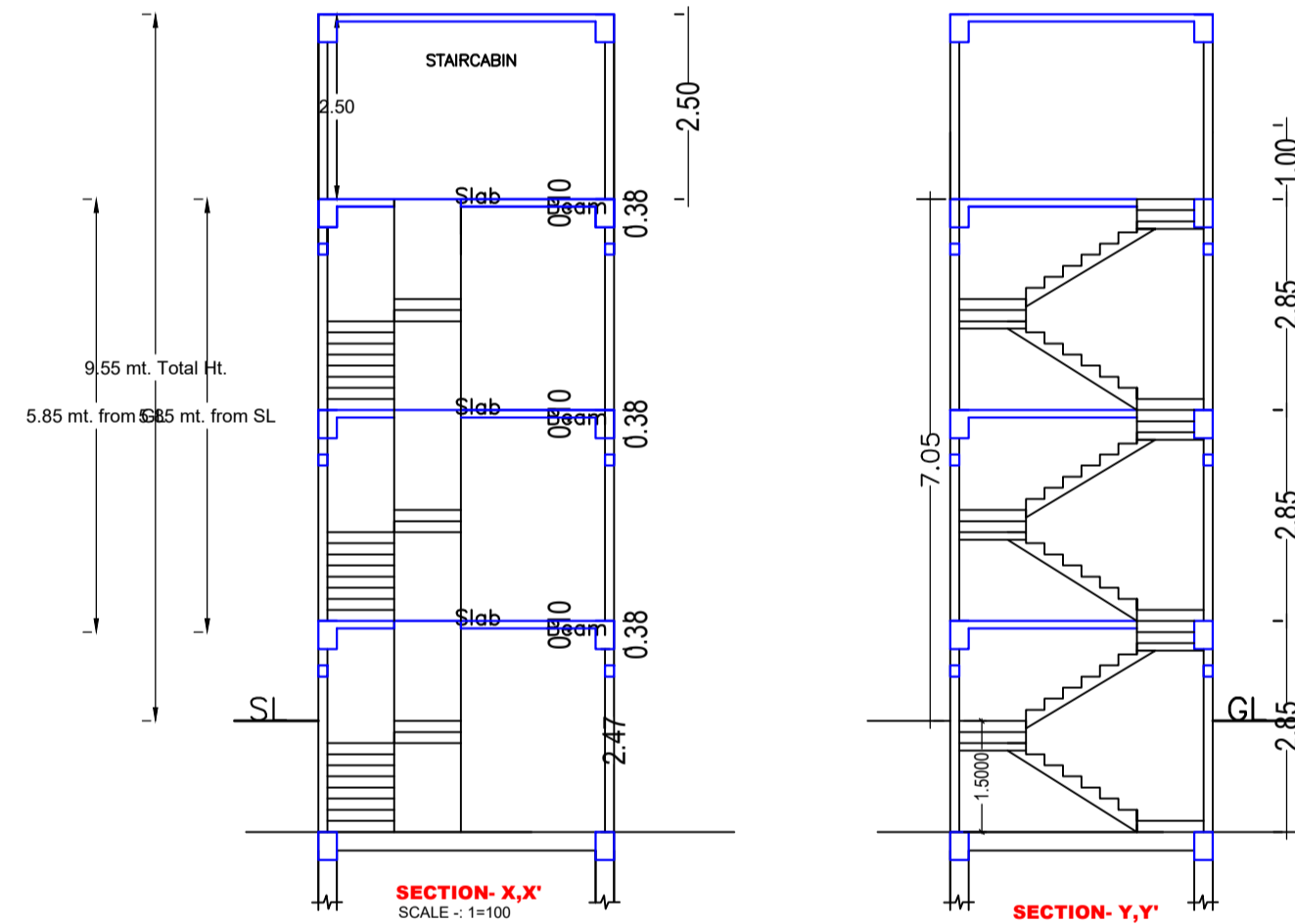

SECTION-X-X'
SCALE :- 1=100

SECTION-Y-Y'
SCALE :- 1=100

Building :AA (SRI BINOD KUMAR)

Floor Name	Total Built Up Area (Sq.mt.)	Proposed FAR Area (Sq.mt.) Resi.	Total FAR Area (Sq.mt.)	Total Consumed Additional FAR Area (Sq.mt.)	Tnmt (No.)
Basement Floor	14.19	14.19	14.19	14.19	01
Ground Floor	14.19	14.19	14.19	14.19	00
First Floor	14.19	14.19	14.19	14.19	00
Terrace Floor	0.00	0.00	0.00	0.00	00
Total :	42.57	42.57	42.57	42.57	01
Total Number of Same Buildings	1				
Total :	42.57	42.57	42.57	42.57	01

SCHEDULE OF DOOR:

BUILDING NAME	NAME	LENGTH	HEIGHT	NOS
AA (SRI BINOD KUMAR)	D2	0.75	2.10	01
AA (SRI BINOD KUMAR)	D	1.00	2.10	03

SCHEDULE OF WINDOW/VENTILATION:

BUILDING NAME	NAME	LENGTH	HEIGHT	NOS
AA (SRI BINOD KUMAR)	V	0.60	0.60	02
AA (SRI BINOD KUMAR)	VO	1.20	0.60	02
AA (SRI BINOD KUMAR)	W	1.20	1.20	02

UnitBUA Table for Building :AA (SRI BINOD KUMAR)

FLOOR	Name	UnitBUA Type	UnitBUA Area	Carpet Area	No. of Rooms	No. of Tenement
BASEMENT FLOOR PLAN	SPLIT FLAT A	FLAT	19.30	19.20	1	1
GROUND FLOOR PLAN	SPLIT FLAT A	FLAT	0.00	0.00	1	0
FIRST FLOOR PLAN	SPLIT FLAT A	FLAT	0.00	0.00	1	0
Total:	-	-	19.30	19.20	3	1

FAR & Tenement Details (Table 4c-1)

Building	No. of Same Bldg	Total Built Up Area (Sq.mt.)	Proposed FAR Area (Sq.mt.) Resi.	Total FAR Area (Sq.mt.)	Total Consumed Additional FAR Area (Sq.mt.)	Tnmt (No.)
AA (SRI BINOD KUMAR)	1	42.57	42.57	42.57	42.57	01
Grand Total :	1	42.57	42.57	42.57	42.57	01

Proposal Basic Information

Proposal File No.	JNP/BB/0065/W10/2024
Owner Name	SRI BINOD KUMAR
Khata No	631
Plot No	7457
Village Name	Tilaiya
Use	Residential
SubUse	Bungalow/ Dwelling / Non Apartment

AREA STATEMENT JHUMRITILAIYA NAGAR PARISHAD VERSION NO.: 1.0.70
VERSION DATE: 16/10/2020

Region: JHARKHAND URBAN LOCAL BODIES	Plot Use: Residential
District: KODERMA	Plot SubUse: Bungalow/ Dwelling / Non Apartment
Authority: JHUMRITILAIYA NAGAR PARISHAD	PlotNearbyReligiousStructure: NA
Inward No: JNP/BB/0065/W10/2024	Plot/SubPlot No: 7457
Application Type: General Proposal	North: Plot No. - LAND OF SANTOSH KUMAR
Project Type: Building Permission	South: Plot No. - LAND OF RAJESH KUMAR & SMT NILAM KUMARI
Nature of Development: New	East: Road Width - 4.57M WIDE ROAD
Location of Development Area: Old Area	West: Plot No. - OWN LAND OF VENDER

AREA DETAILS:		SQ.MT.
AREA OF PLOT (Minimum)	(A)	29.25
NET AREA OF PLOT(Gross Plot Area - Deduction from Gross Plot area)	(A-Deductions)	29.25
Deduction for Balance Plot Area(from Gross Plot Area)		
Common Plot		2.86
Total		2.86
BALANCE AREA OF PLOT(Net Plot Area - Recreational/Amenity space)	(A-Deductions)	26.39
PLOT AREA FOR COVERAGE(Net Plot Area)	(A-Deductions)	29.25
Plot Area for FAR (Net Plot Area + Road Widening Area)	(A-Deductions)	29.25
COVERAGE CHECK		
Permissible Coverage area (70.00 %)		20.48
Proposed Coverage Area (48.52 %)		14.19
Total Prop. Coverage Area (48.52 %)		14.19
Balance coverage area (21.51 %)		6.29

FAR CHECK		
Perm. FAR Area (1.500)		43.88
Total Perm. FAR area		43.88
Residential FAR		42.58
Proposed FAR Area		42.58
Total Proposed FAR Area		42.58
Consumed FAR (Factor)		1.46
Balance FAR Area		1.30
BUILT UP AREA CHECK		
Total Proposed BuiltUp Area		42.57
ARCHITECT (Regd)		MD SHOAB ALAM
ENGINEER (Regd)		
SUPERVISOR (Regd)		
OWNER (Regd)		SRI BINOD KUMAR
DEVELOPMENT AUTHORITY		LOCAL BODY

COLOR INDEX	
PLOT BOUNDARY	Black
ABUTTING ROAD	Green
PROPOSED CONSTRUCTION	Red
COMMON PLOT	Yellow
ROAD WIDENING AREA	Blue
EXISTING (To be retained)	Light Blue
EXISTING (To be demolished)	Dark Blue

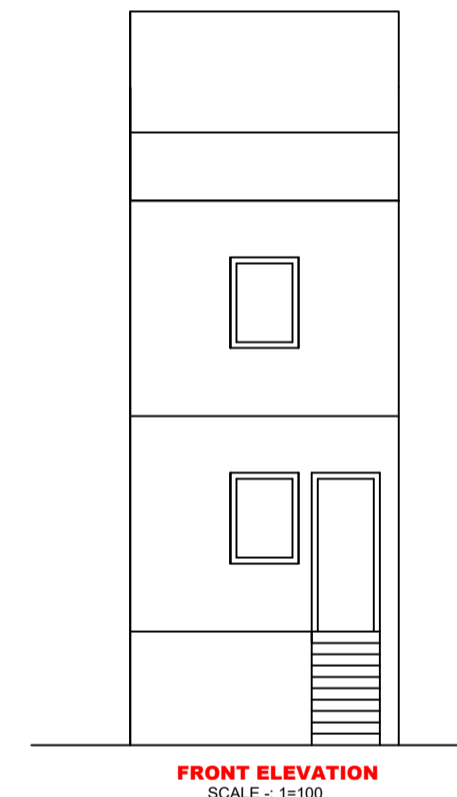
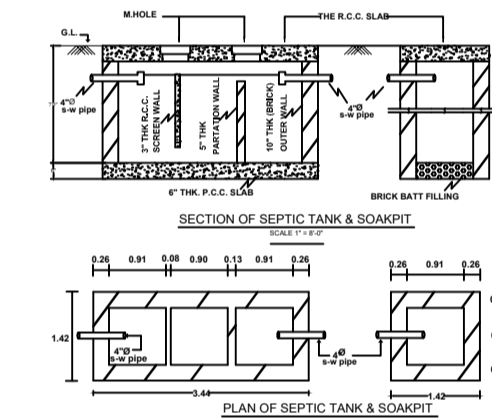
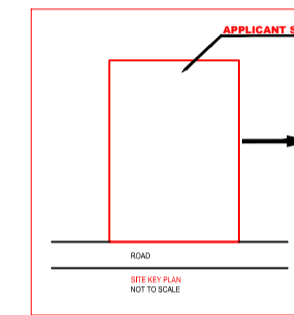
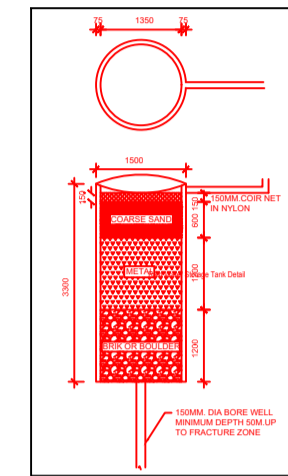

FRONT ELEVATION
SCALE :- 1=100

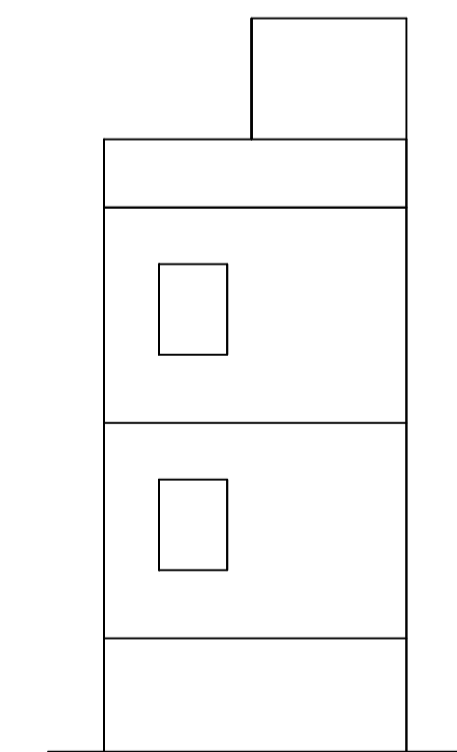

SIDE ELEVATION
SCALE :- 1=100

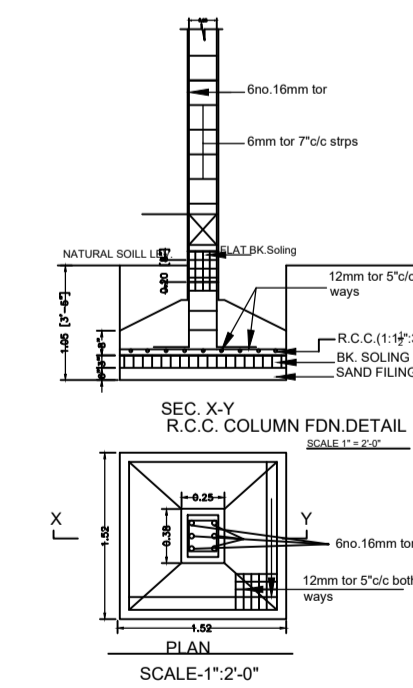

SCALE:1:2'-0"

Buildingwise Floor FAR Details

Floor Name	Building Name AA (SRI BINOD KUMAR)		Total	
	Proposed Built Up Area (Sq.mt.)	Proposed FAR Area (Sq.mt.)	Total Proposed Built Up Area (Sq.mt.)	Total FAR Area (Sq.mt.)
Basement Floor	14.19	14.19	14.19	14.19
Ground Floor	14.19	14.19	14.19	14.19
First Floor	14.19	14.19	14.19	14.19
Terrace Floor	0.00	0.00	0.00	0.00
Total :	42.57	42.57	42.57	42.57

Building USE/SUBUSE Details

Building Name	Building Use	Building SubUse	Building Structure
AA (SRI BINOD KUMAR)	Residential	Bungalow/ Dwelling / Non Apartment	Non-Highrise

LTP NAME AND SIGNATURE	STRUCTURAL ENG'S NAME AND SIGNATURE	BUILDER NAME AND SIGNATURE	DIGITAL SIGNATURE
MD SHOAB ALAM JNP/ENG/0001/2017			