

**SITE PLAN**

SITE PLAN

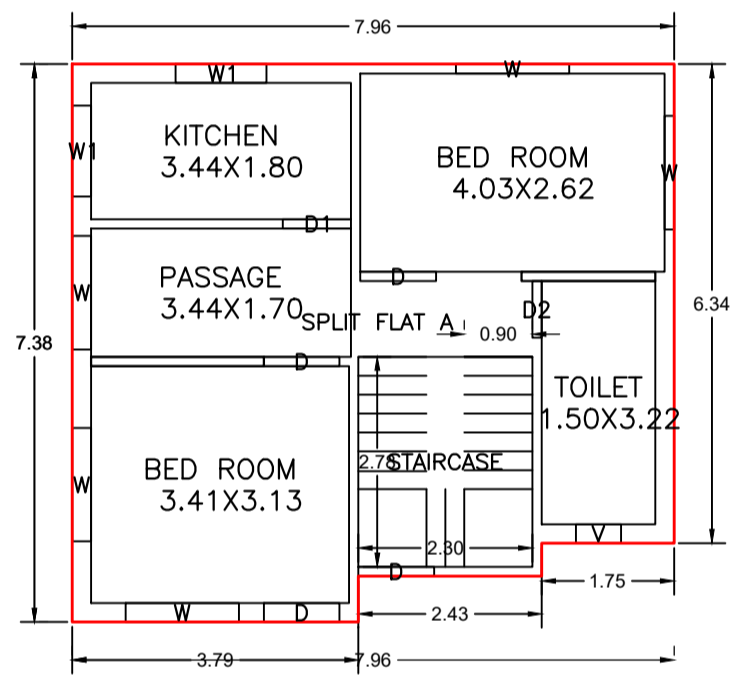

**GROUND FLOOR PLAN (Proposed)**  
(SCALE 1:100)

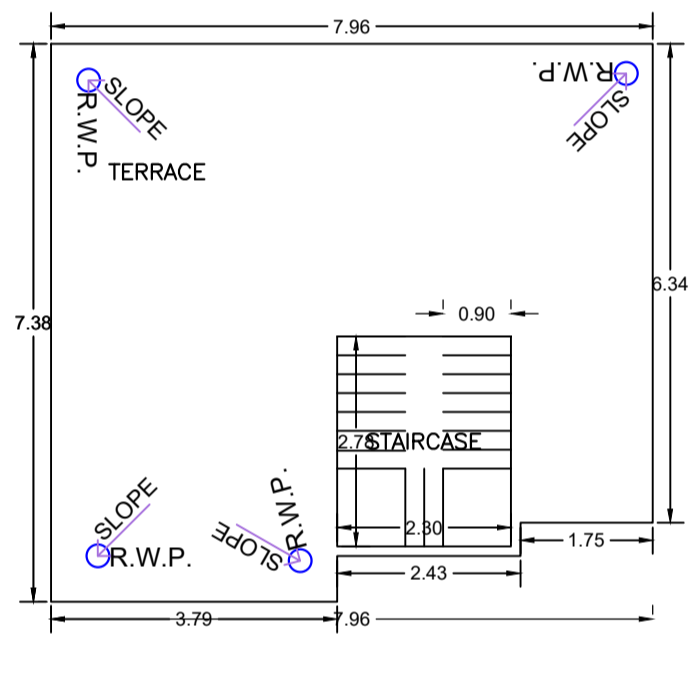

**TERRACE FLOOR PLAN (SCALE 1:100)**

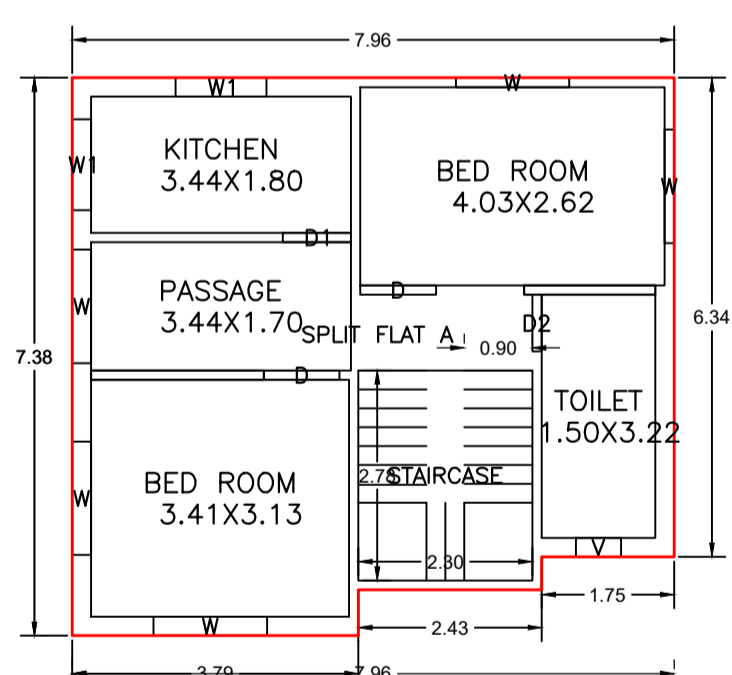

**FIRST FLOOR PLAN (Proposed)**  
(SCALE 1:100)

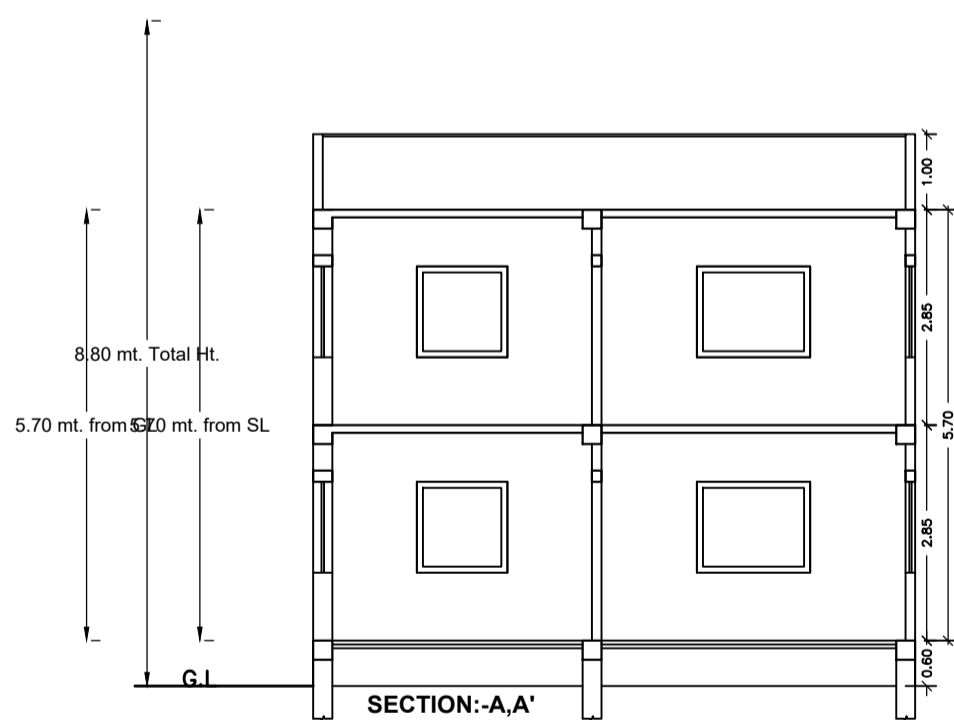

**SECTION -A-A'**

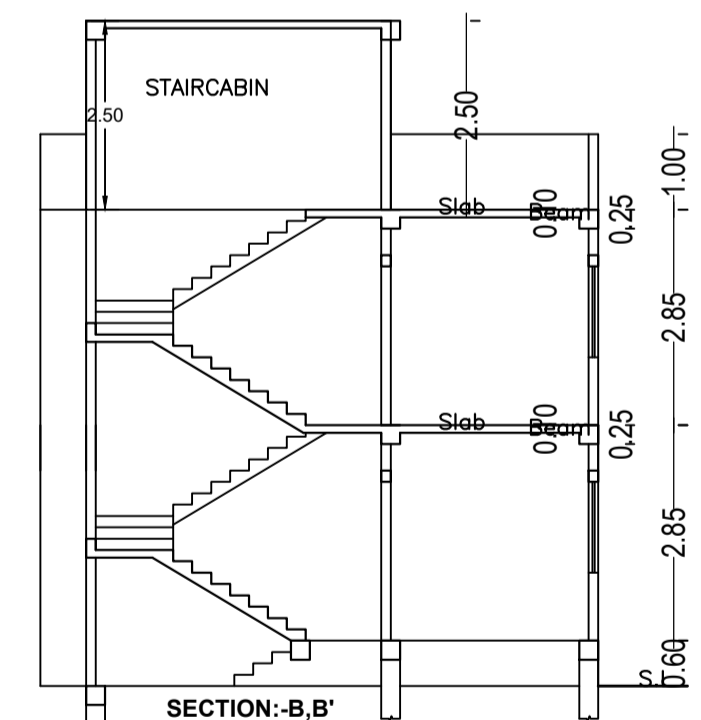

**SECTION -B-B'**

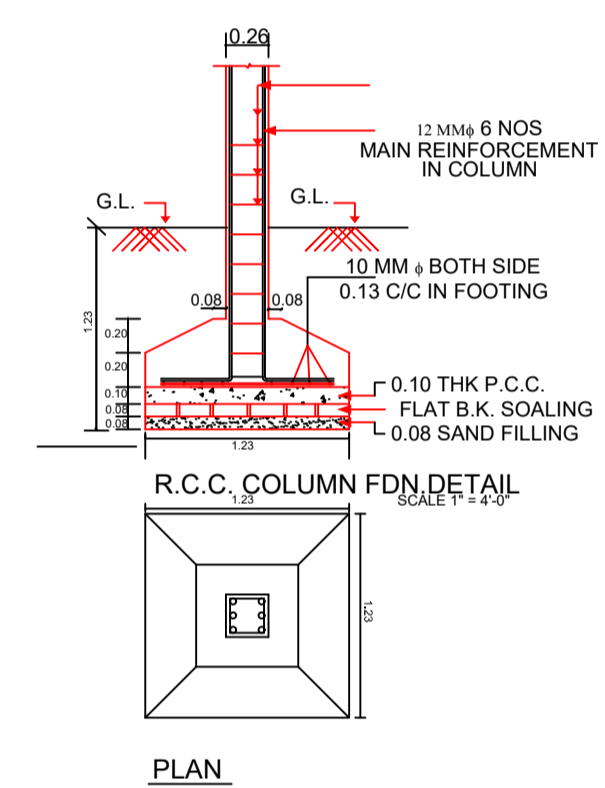

**PLAN**

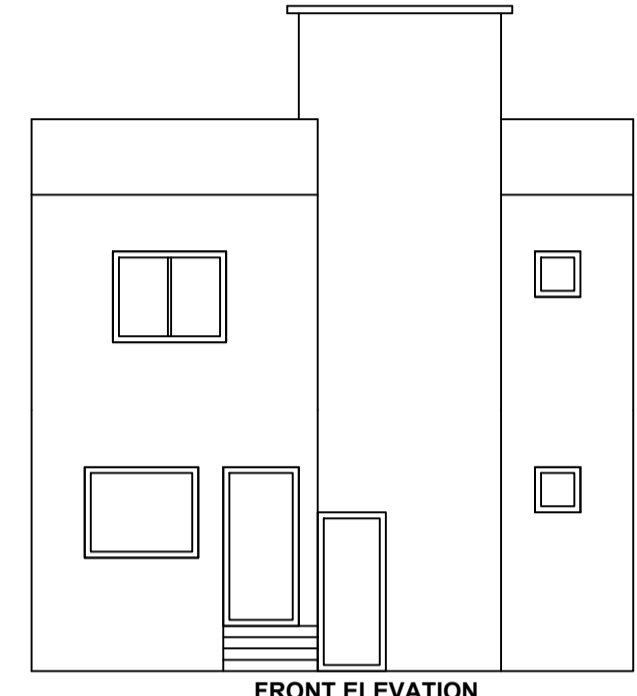

**FRONT ELEVATION**

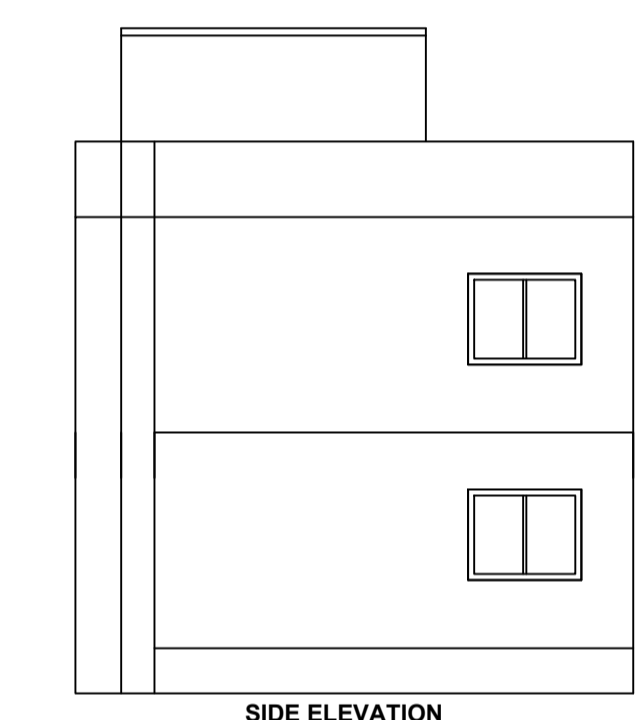

**SIDE ELEVATION**

Proposal Basic Information	
Proposal File No.	JNP/ENG/0001/2024
Owner Name	SRI SHANKAR SAW
Khata No	48
Plot No	3232 N
Village Name	Tilayi
Use	Residential
SubUse	Bungalow/ Dwelling / Non Apartment

AREA STATEMENT		VERSION NO.:	1.0.70
JHUMRITILAIYA NAGAR PARISHAD		VERSION DATE:	16/10/2020
<b>PROJECT DETAIL:</b>			
Region: JHARKHAND URBAN LOCAL BODIES	Plot Use:	Residential	
District: KODERMA	Plot SubUse:	Bungalow/ Dwelling / Non Apartment	
Authority: JHUMRITILAIYA NAGAR PARISHAD	PlotNearby/ReligiousStructure:	NA	
Inward No: JNP/BP/0067/W02/2024	PlotSubPlot No:	3232	
Application Type: General Proposal	North: Road Width -	3.66M WIDE ROAD	
Project Type: Building Permission	South: Plot No. -	DHANNU SAW OTHERS	
Nature of Development: New	East: Plot No. -	NIZ VENDOR	
Location of Development Area: Old Area	West: Plot No. -	NIZ VENDOR	
<b>AREA DETAILS:</b>			
AREA OF PLOT (Minimum)	(A)	SQ.MT.	168.15
NET AREA OF PLOT(Gross Plot Area - Deduction from Gross Plot area)	(A-Deductions)		168.15
Deduction for Balance Plot Area(from Gross Plot Area)			
Common Plot			10.53
Total			10.53
BALANCE AREA OF PLOT(Net Plot Area - Recreational/Amenity space)	(A-Deductions)		157.62
PLOT AREA FOR COVERAGE(Net Plot Area)	(A-Deductions)		168.15
Plot Area for FAR (Net Plot Area + Road Widening Area)	(A-Deductions)		168.15
<b>COVERAGE CHECK</b>			
Permissible Coverage area ( 70.00 % )			117.70
Proposed Coverage Area ( 32.98 % )			55.45
Total Prop. Coverage Area ( 32.98 % )			55.45
Balance coverage area ( 37.02 % )			62.25
<b>FAR CHECK</b>			
Perm. FAR Area ( 1.500 )			252.22
Total Perm. FAR area			252.22
Residential FAR			110.90
Proposed FAR Area			110.90
Total Proposed FAR Area			110.90
Consumed FAR (Factor)			0.66
Balance FAR Area			141.32
<b>BUILT UP AREA CHECK</b>			
Total Proposed BuiltUp Area			110.90
ARCHITECT (Regd)	MD SHOAB ALAM		
ENGINEER (Regd)			
SUPERVISOR (Regd)			
OWNER (Regd)	SRI SHANKAR SAW		
DEVELOPMENT AUTHORITY		LOCAL BODY	

COLOR INDEX	
PLOT BOUNDARY	Black
ABUTTING ROAD	Green
PROPOSED CONSTRUCTION	Red
COMMON PLOT	Yellow
ROAD WIDENING AREA	Orange
EXISTING (To be retained)	Blue
EXISTING (To be demolished)	Light Blue

**Buildingwise Floor FAR Details**

Floor Name	Building Name AA (SRI SHANKAR SAW)		Total	
	Proposed Built Up Area (Sq.mt.)	Proposed FAR Area (Sq.mt.)	Total Proposed Built Up Area (Sq.mt.)	Total FAR Area (Sq.mt.)
Ground Floor	55.45	55.45	55.45	55.45
First Floor	55.45	55.45	55.45	55.45
Terrace Floor	0.00	0.00	0.00	0.00
<b>Total :</b>	<b>110.90</b>	<b>110.90</b>	<b>110.90</b>	<b>110.90</b>

**Building USE/SUBUSE Details**

Building Name	Building Use	Building SubUse	Building Structure
AA (SRI SHANKAR SAW)	Residential	Bungalow/ Dwelling / Non Apartment	Non-Highrise

**FAR & Tenement Details (Table 4c-1)**

Building	No. of Same Bldg	Total Built Up Area (Sq.mt.)	Proposed FAR Area (Sq.mt.)	Total FAR Area (Sq.mt.)	Total Consumed Additional FAR Area (Sq.mt.)	Tnmt (No.)
AA (SRI SHANKAR SAW)	1	110.90	110.90	110.90	110.90	01
<b>Grand Total :</b>	<b>1</b>	<b>110.90</b>	<b>110.90</b>	<b>110.90</b>	<b>110.90</b>	<b>01</b>

**SCHEDULE OF DOOR:**

BUILDING NAME	NAME	LENGTH	HEIGHT	NOS
AA (SRI SHANKAR SAW)	D2	0.75	2.10	02
AA (SRI SHANKAR SAW)	D1	0.90	2.10	02
AA (SRI SHANKAR SAW)	D	1.00	2.10	05

**SCHEDULE OF WINDOW/VENTILATION:**

BUILDING NAME	NAME	LENGTH	HEIGHT	NOS
AA (SRI SHANKAR SAW)	V	0.60	0.60	02
AA (SRI SHANKAR SAW)	W1	1.20	1.20	04
AA (SRI SHANKAR SAW)	W	1.50	1.20	10

**UnitBUA Table for Building :AA (SRI SHANKAR SAW)**

FLOOR	Name	UnitBUA Type	UnitBUA Area	Carpet Area	No. of Rooms	No. of Tenement
GROUND FLOOR PLAN	SPLIT FLAT A	FLAT	84.50	83.49	5	1
FIRST FLOOR PLAN	SPLIT FLAT A	FLAT	0.00	0.00	5	0
<b>Total:</b>	-	-	<b>84.50</b>	<b>83.49</b>	<b>10</b>	<b>1</b>

**Building :AA (SRI SHANKAR SAW)**

Floor Name	Total Built Up Area (Sq.mt.)	Proposed FAR Area (Sq.mt.)	Total FAR Area (Sq.mt.)	Total Consumed Additional FAR Area (Sq.mt.)	Tnmt (No.)
Ground Floor	55.45	55.45	55.45	55.45	01
First Floor	55.45	55.45	55.45	55.45	00
Terrace Floor	0.00	0.00	0.00	0.00	00
<b>Total :</b>	<b>110.90</b>	<b>110.90</b>	<b>110.90</b>	<b>110.90</b>	<b>01</b>
<b>Total Number of Same Buildings :</b>	<b>1</b>				
<b>Total :</b>	<b>110.90</b>	<b>110.90</b>	<b>110.90</b>	<b>110.90</b>	<b>01</b>

LTP NAME AND SIGNATURE	STRUCTURAL ENG'S NAME AND SIGNATURE	BUILDER NAME AND SIGNATURE	DIGITAL SIGNATURE
MD SHOAB ALAM JNP/ENG/0001/2017			