

TERRACE FLOOR PLAN (SCALE 1:100)

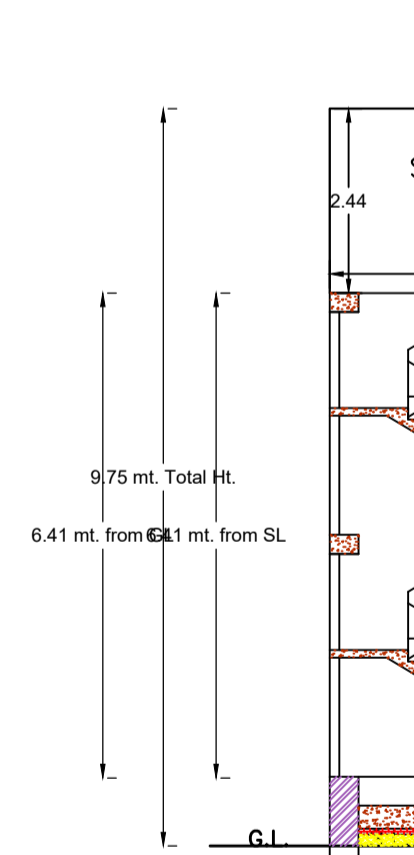

GROUND FLOOR PLAN (Proposed) (SCALE 1:100)

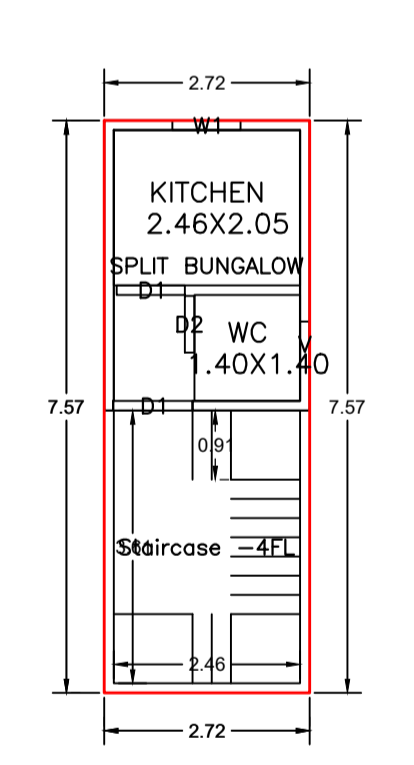

FIRST FLOOR PLAN (Proposed) (SCALE 1:100)

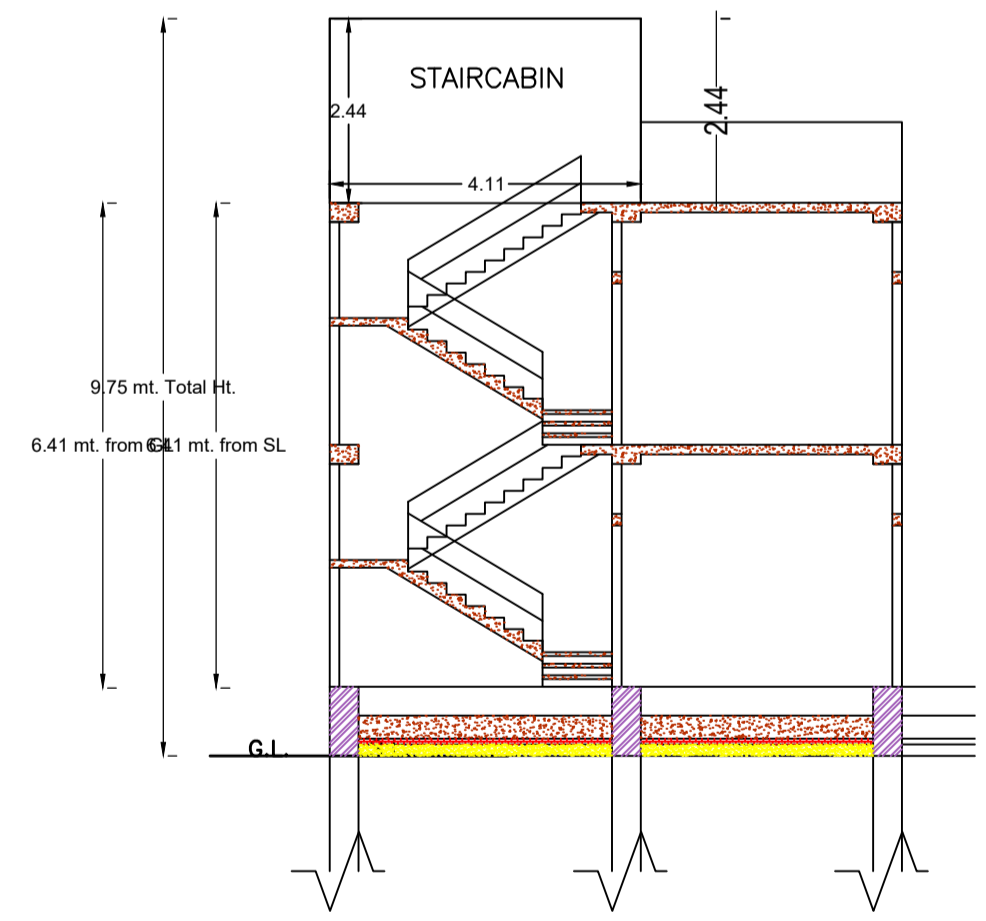

CROSS SECTION (A)

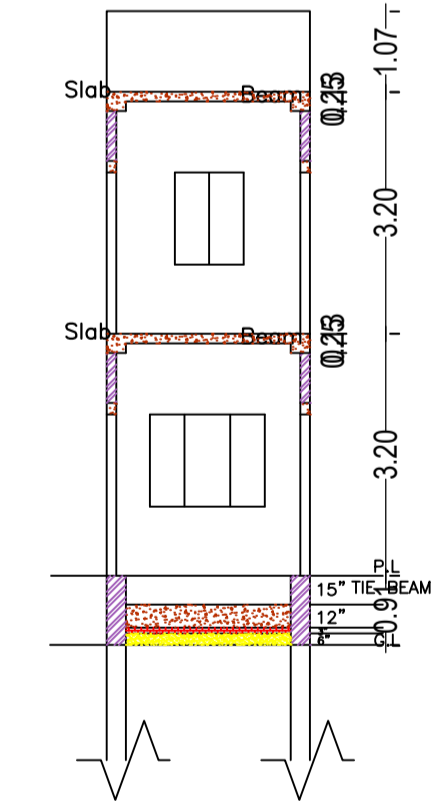

CROSS SECTION (B)

Building :A (RESIDENTIAL)

Floor Name	Total Built Up Area (Sq.mt.)	Proposed FAR Area (Sq.mt.)	Total FAR Area (Sq.mt.)	Total Consumed Additional FAR Area (Sq.mt.)	Tnmt (No.)
Ground Floor	20.57	20.57	20.57	20.57	01
First Floor	20.57	20.57	20.57	20.57	00
Terrace Floor	0.00	0.00	0.00	0.00	00
Total :	41.14	41.14	41.14	41.14	01
Total Number of Same Buildings :	1				
Total :	41.14	41.14	41.14	41.14	01

SCHEDULE OF DOOR:

BUILDING NAME	NAME	LENGTH	HEIGHT	NOS
A (RESIDENTIAL)	D2	0.75	2.10	01
A (RESIDENTIAL)	D1	0.90	2.10	01
A (RESIDENTIAL)	D1	1.05	2.10	01

SCHEDULE OF WINDOW/VENTILATION:

BUILDING NAME	NAME	LENGTH	HEIGHT	NOS
A (RESIDENTIAL)	V	0.60	0.90	01
A (RESIDENTIAL)	W1	0.90	1.20	01
A (RESIDENTIAL)	W	1.50	1.20	01

UnitBUA Table for Building :A (RESIDENTIAL)

FLOOR	Name	UnitBUA Type	UnitBUA Area	Carpet Area	No. of Rooms	No. of Tenement
GROUND FLOOR PLAN	SPLIT BUNGALOW	FLAT	20.85	17.91	1	1
FIRST FLOOR PLAN	SPLIT BUNGALOW	FLAT	0.00	0.00	2	0
Total:	-	-	20.85	17.91	3	1

FAR & Tenement Details (Table 4c-1)

Building	No. of Same Bldg	Total Built Up Area (Sq.mt.)	Proposed FAR Area (Sq.mt.)	Total FAR Area (Sq.mt.)	Total Consumed Additional FAR Area (Sq.mt.)	Tnmt (No.)
A (RESIDENTIAL)	1	41.14	41.14	41.14	41.14	01
Grand Total :	1	41.14	41.14	41.14	41.14	01

Proposal Basic Information

Proposal File No.	JNP/BP/0070/W12/2024
Owner Name	(1) SRI MANIK CHAND PRASAD (2) SRI LALAN PRASAD
Khata No	440
Plot No	7287
Village Name	Tilaiya
Use	Residential
SubUse	Bungalow/ Dwelling / Non Apartment

AREA STATEMENT

JHUMRITILAIYA NAGAR
PARISHAD

PROJECT DETAIL:

Region: JHARKHAND URBAN LOCAL BODIES
District: KODERMA
Authority: JHUMRITILAIYA NAGAR PARISHAD
Inward No: JNP/BP/0070/W12/2024
Application Type: General Proposal
Project Type: Building Permission
Nature of Development: New
Location of Development Area: Old Area

Plot Use: Residential
Plot SubUse: Bungalow/ Dwelling / Non Apartment
Plot/Nearby/Religious/Structure: NA
Plot/SubPlot No: 7287
North: Plot No. - LAND OF SMT SHUSMA DEVI
South: Plot No. - LAND OF SMT SHANTI DEV AND NARESH SAW
East: Plot No. - LAND OF SMT LALITA DEV
West: Road Width - 4.57 METER GURUDAWRA ROAD

VERSION NO.: 1.0.70
VERSION DATE: 16/10/2020

AREA DETAILS:		SQ.MT.
AREA OF PLOT (Minimum)	(A)	41.07
NET AREA OF PLOT(Gross Plot Area - Deduction from Gross Plot area)	(A-Deductions)	41.07
Deduction for Balance Plot Area(from Gross Plot Area)		
Common Plot		5.58
Total		5.58
BALANCE AREA OF PLOT(Net Plot Area - Recreational/Amenity space)	(A-Deductions)	35.49
PLOT AREA FOR COVERAGE(Net Plot Area)	(A-Deductions)	41.07
Plot Area for FAR (Net Plot Area + RoadWidening Area)	(A-Deductions)	41.07
COVERAGE CHECK		
Permissible Coverage area (70.00 %)		28.75
Proposed Coverage Area (50.09 %)		20.57
Total Prop. Coverage Area (50.09 %)		20.57
Balance coverage area (19.92 %)		8.18
FAR CHECK		
Perm. FAR Area (1.500)		61.60
Total Perm. FAR area		61.60
Residential FAR		41.14
Proposed FAR Area		41.14
Total Proposed FAR Area		41.14
Consumed FAR (Factor)		1.00
Balance FAR Area		20.46
BUILT UP AREA CHECK		
Total Proposed BuiltUp Area		41.14
ARCHITECT (Regd)	KIRAN KUMARI	
ENGINEER (Regd)		
SUPERVISOR (Regd)		
OWNER (Regd)	(1) SRI MANIK CHAND PRASAD (2) SRI LALAN PRASAD	
DEVELOPMENT AUTHORITY	LOCAL BODY	

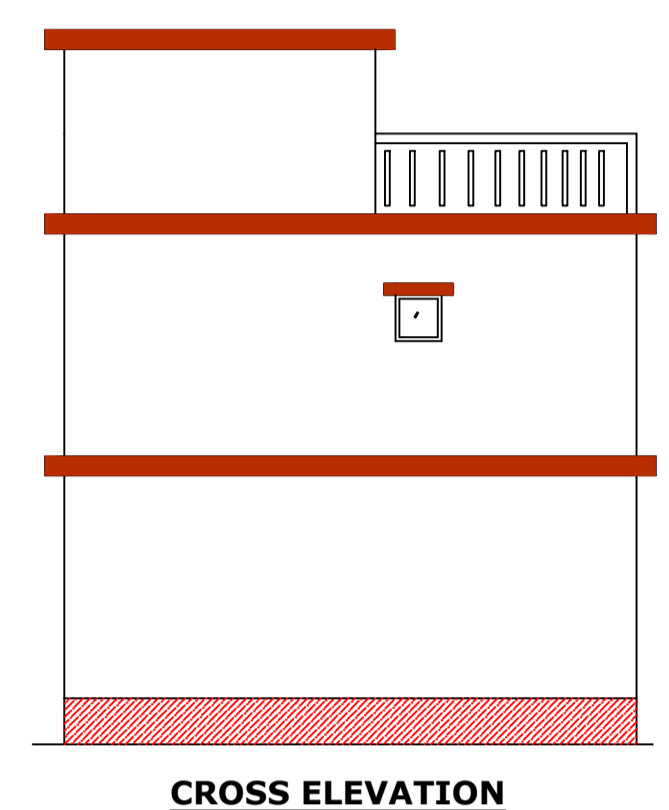

CROSS ELEVATION

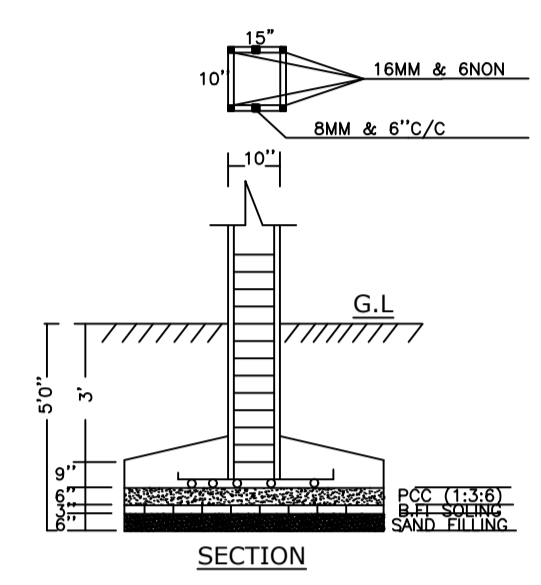

SECTION

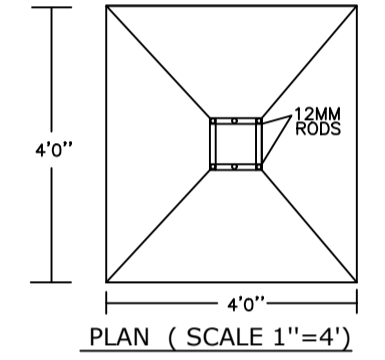

PLAN (SCALE 1"=4')

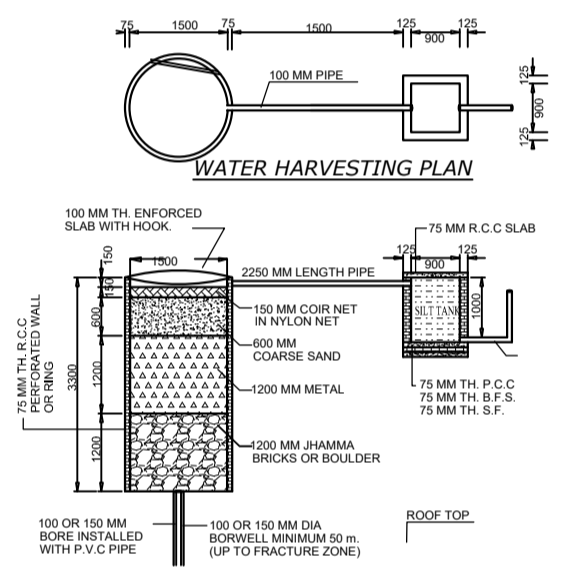

WATER HARVESTING PLAN

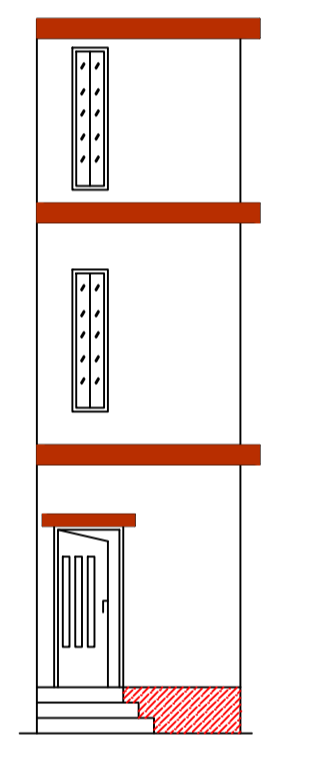

FRONT ELEVATION

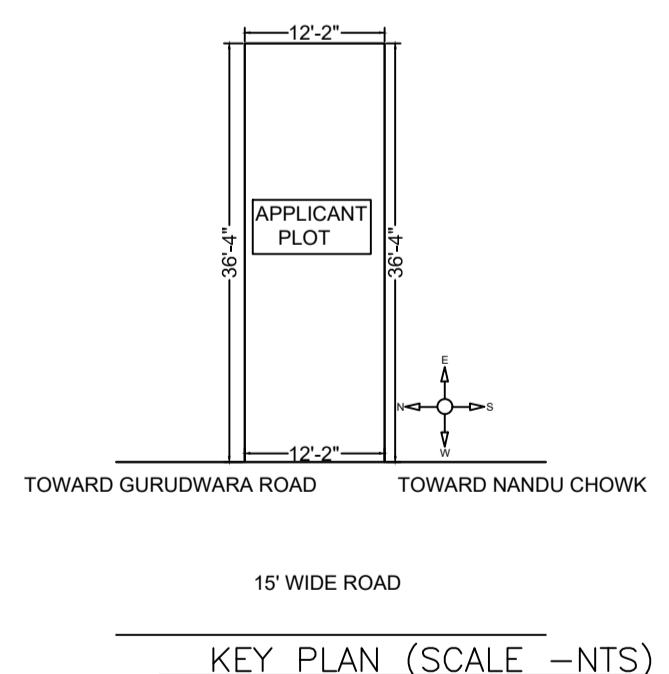

KEY PLAN (SCALE -1NTS)

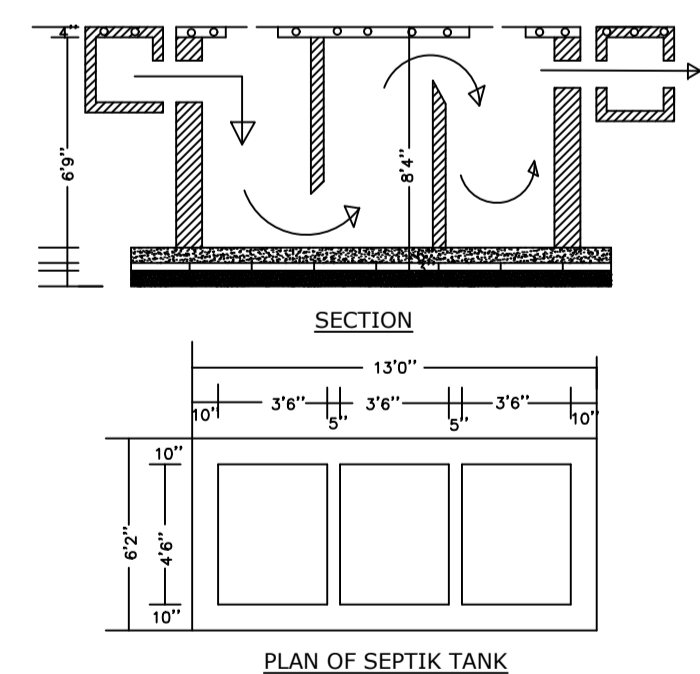

PLAN OF SEPTIK TANK

COLOR INDEX

PLOT BOUNDARY	Black
ABUTTING ROAD	Green
PROPOSED CONSTRUCTION	Red
COMMON PLOT	Yellow
ROAD WIDENING AREA	Blue
EXISTING (To be retained)	Orange
EXISTING (To be demolished)	Light Blue

Buildingwise Floor FAR Details

Floor Name	Building Name A (RESIDENTIAL)		Total	
	Proposed Built Up Area (Sq.mt.)	Proposed FAR Area (Sq.mt.)	Total Proposed Built Up Area (Sq.mt.)	Total FAR Area (Sq.mt.)
Ground Floor	20.57	20.57	20.57	20.57
First Floor	20.57	20.57	20.57	20.57
Terrace Floor	0.00	0.00	0.00	0.00
Total :	41.14	41.14	41.14	41.14

Building USE/SUBUSE Details

Building Name	Building Use	Building SubUse	Building Structure
A (RESIDENTIAL)	Residential	Bungalow/ Dwelling / Non Apartment	Non-Highrise

LTP NAME AND SIGNATURE	STRUCTURAL ENG'S NAME AND SIGNATURE	BUILDER NAME AND SIGNATURE	DIGITAL SIGNATURE
KIRAN KUMARI JNP/ENG/0001/2019			

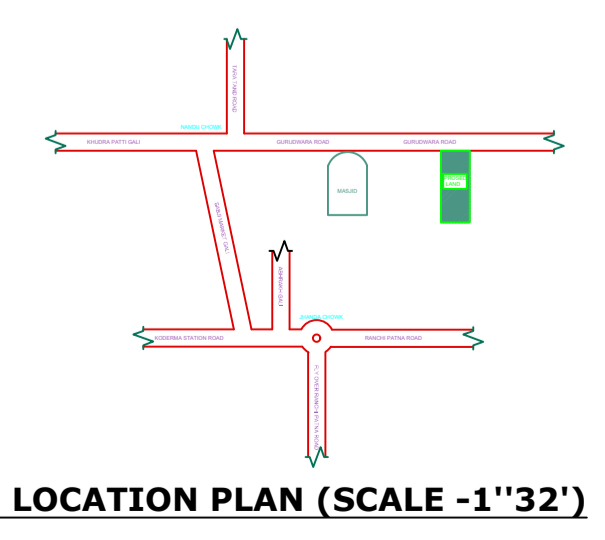

LOCATION PLAN (SCALE -1'32')