

Proposal Basic Information	
Proposal File No.	JNRP/0068/W07/2024
Owner Name	SHABBIR ALAM
Khata No.	18
Plot No.	68
Village Name	Jhalpo
Use	Residential
SubUse	Bungalow Dwelling / Non Apartment
AREA STATEMENT	VERSION NO. 1.0.70
JHMIRTLAYA NAGAR PARSHAD	VERSION DATE: 16/10/2020
PROJECT DETAIL:	
Region: JHARKHAND URBAN LOCAL BODIES	Plot Use: Residential
District: HOOGHMA	Plot SubUse: Bungalow Dwelling / Non Apartment
Authority: JHMIRTLAYA NAGAR PARSHAD	Plot Nearby/Religious/Structure: NA
Project No.: JNRP/0068/W07/2024	Plot SubPlot No.: 68
Application Type: General Proposal	North: Road Width - 3.66M WIDE KATCHA RASTA
Project Type: Building Permission	South: Plot No. - LAND OF MD YASIN & OTHER
Nature of Development: New	East: Plot No. - LAND OF SHABANA KHATUN
Location of Development Area: Old Area	West: Road Width - 3.66M WIDE P.C.C ROAD
AREA DETAILS:	SQ.MT
AREA OF PLOT (Minimum)	(A)
NET AREA OF PLOT (Gross Plot Area)	153.94
- Deduction from Gross Plot Area	(A-Deductions)
153.94	
Deduction for Balance Plot Area (from Gross Plot Area)	
Common Plot	13.77
Total	13.77
BALANCE AREA OF PLOT (Net Plot Area - Recreational/Amenity space)	(A-Deductions)
140.17	
PLOT AREA FOR COVERAGE (Net Plot Area)	(A-Deductions)
153.94	
Plot Area for FAR (Net Plot Area + Road/Widening Area)	(A-Deductions)
153.94	
COVERAGE CHECK	
Permissible Coverage area ( 70.00 % )	107.76
Proposed Coverage Area ( 47.57 % )	73.23
Total Prop. Coverage Area ( 47.57 % )	73.23
Balance coverage area ( 22.43 % )	34.53
FAR CHECK	
Perm. FAR Area ( 1.500 )	230.91
Total Perm. FAR area	230.91
Residential FAR	207.71
Proposed FAR Area	207.71
Total Proposed FAR Area	207.71
Consumed FAR (Factor)	1.35
Balance FAR Area	23.20
BUILT UP AREA CHECK	
Total Proposed BuiltUp Area	219.69
ARCHITECT (Regd)	MD SHOHAB ALAM
ENGINEER (Regd)	
SUPERVISOR (Regd)	
OWNER (Regd)	SHABBIR ALAM
DEVELOPMENT AUTHORITY	LOCAL BODY

COLOR INDEX	
PLOT BOUNDARY	Green
ABUTTING ROAD	Red
PROPOSED CONSTRUCTION	Orange
COMMON PLOT	Yellow
ROAD WIDENING AREA	Blue
EXISTING (To be retained)	Light Blue
EXISTING (To be demolished)	Dark Blue

Buildingwise Floor FAR Details				
Floor Name	Building Name		Total	
	Proposed Built Up Area (Sq.mt)	Proposed FAR Area (Sq.mt)	Total Proposed Built Up Area (Sq.mt)	Total FAR Area (Sq.mt)
Ground Floor	73.23	61.26	73.23	61.26
First Floor	73.23	73.23	73.23	73.23
Second Floor	73.23	73.23	73.23	73.23
Terrace Floor	0.00	0.00	0.00	0.00
Total:	219.69	207.72	219.69	207.72

Building USE/SUBUSE Details			
Building Name	Building Use	Building SubUse	Building Structure
AA (SHABBIR ALAM)	Residential	Bungalow Dwelling / Non Apartment	Non-Highrise

FAR & Tenement Details (Table 4c-1)							
Building	No. of Same Bldg	Total Built Up Area (Sq.mt)	Deductions (Area in Sq.mt)	Proposed FAR Area (Sq.mt)	Total FAR Area (Sq.mt)	Total Consumed Additional FAR Area (Sq.mt)	Tnmt (No.)
AA (SHABBIR ALAM)	1	219.69	11.97	207.72	207.72	207.72	01
Grand Total:	1	219.69	11.97	207.72	207.72	207.72	01

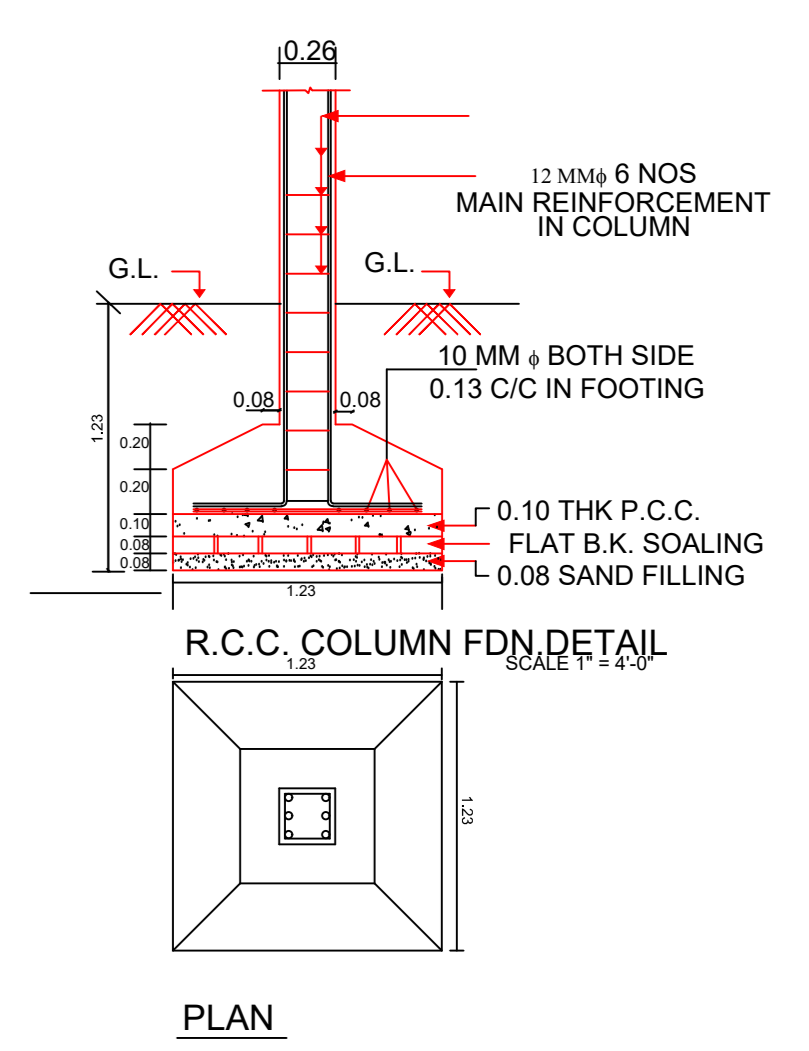
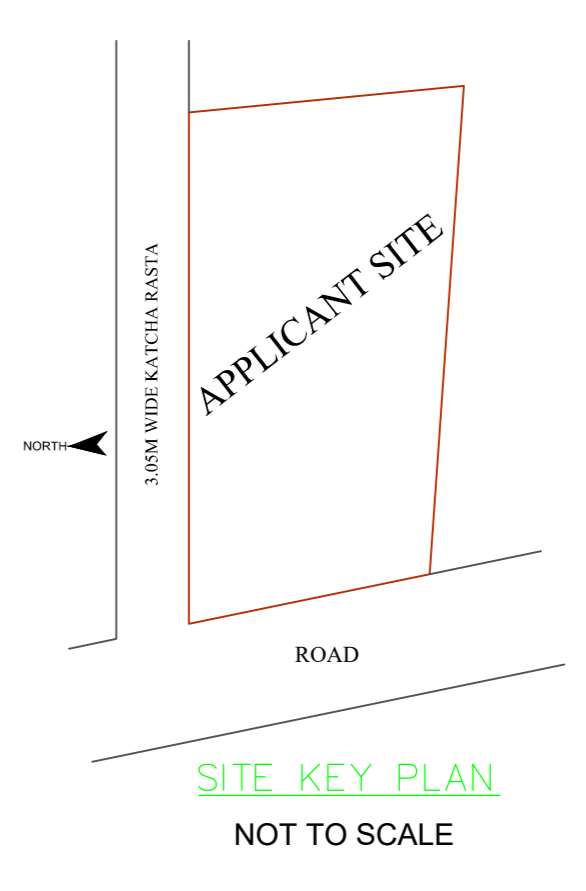

Building :AA (SHABBIR ALAM)						
Floor Name	Total Built Up Area (Sq.mt)	Deductions (Area in Sq.mt)	Proposed FAR Area (Sq.mt)	Total FAR Area (Sq.mt)	Total Consumed Additional FAR Area (Sq.mt)	Tnmt (No.)
Ground Floor	73.23	11.97	61.26	61.26	61.26	01
First Floor	73.23	0.00	73.23	73.23	73.23	00
Second Floor	73.23	0.00	73.23	73.23	73.23	00
Terrace Floor	0.00	0.00	0.00	0.00	0.00	00
Total:	219.69	11.97	207.72	207.72	207.72	01
Total Number of Same Buildings	1					
Total:	219.69	11.97	207.72	207.72	207.72	01

SCHEDULE OF DOOR:						
BUILDING NAME	NAME	LENGTH	HEIGHT	NOS		
AA (SHABBIR ALAM)	D2	0.65	2.10	01		
AA (SHABBIR ALAM)	D2	0.75	2.10	05		
AA (SHABBIR ALAM)	D1	0.90	2.10	05		
AA (SHABBIR ALAM)	D	1.00	2.10	05		

SCHEDULE OF WINDOW/VENTILATION:						
BUILDING NAME	NAME	LENGTH	HEIGHT	NOS		
AA (SHABBIR ALAM)	V	0.60	0.60	05		
AA (SHABBIR ALAM)	W1	1.20	1.20	05		
AA (SHABBIR ALAM)	W	1.50	1.20	22		

UnitBUA Table for Building :AA (SHABBIR ALAM)						
FLOOR	Name	UnitBUA Type	UnitBUA Area	Carpet Area	No. of Rooms	No. of Tenement
GROUND FLOOR PLAN	SPLIT FLAT A	FLAT	166.34	166.58	7	1
TYPICAL 1& 2 FLOOR PLAN	SPLIT FLAT A	FLAT	0.00	0.00	8	0
Total:	-	-	166.34	166.58	23	1

LTP NAME AND SIGNATURE	STRUCTURAL ENG'S NAME AND SIGNATURE	BUILDER NAME AND SIGNATURE	DIGITAL SIGNATURE
MD SHOHAB ALAM JNRPEN/300012017			