

Proposal Basic Information

Proposal File No.	JNP/BP/0024/W22/2024
Owner Name	SMT PUJA KUMARI
Khata No	294, 296, 302
Plot No	1222, 1220, 1227
Village Name	Gomo
Use	Residential
SubUse	Bungalow/ Dwelling / Non Apartment

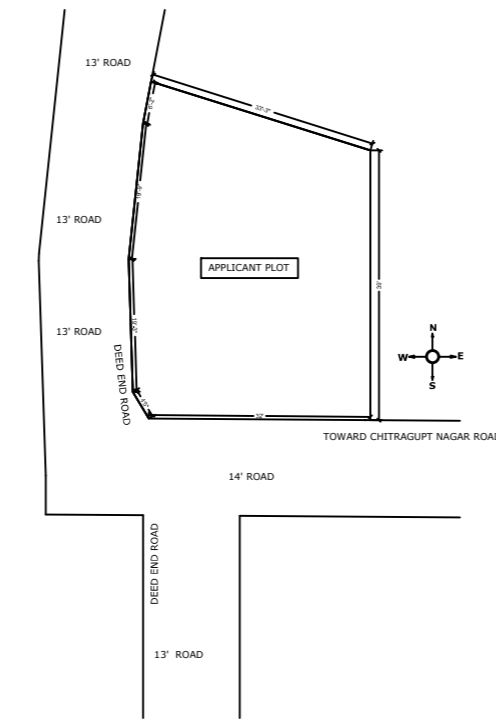
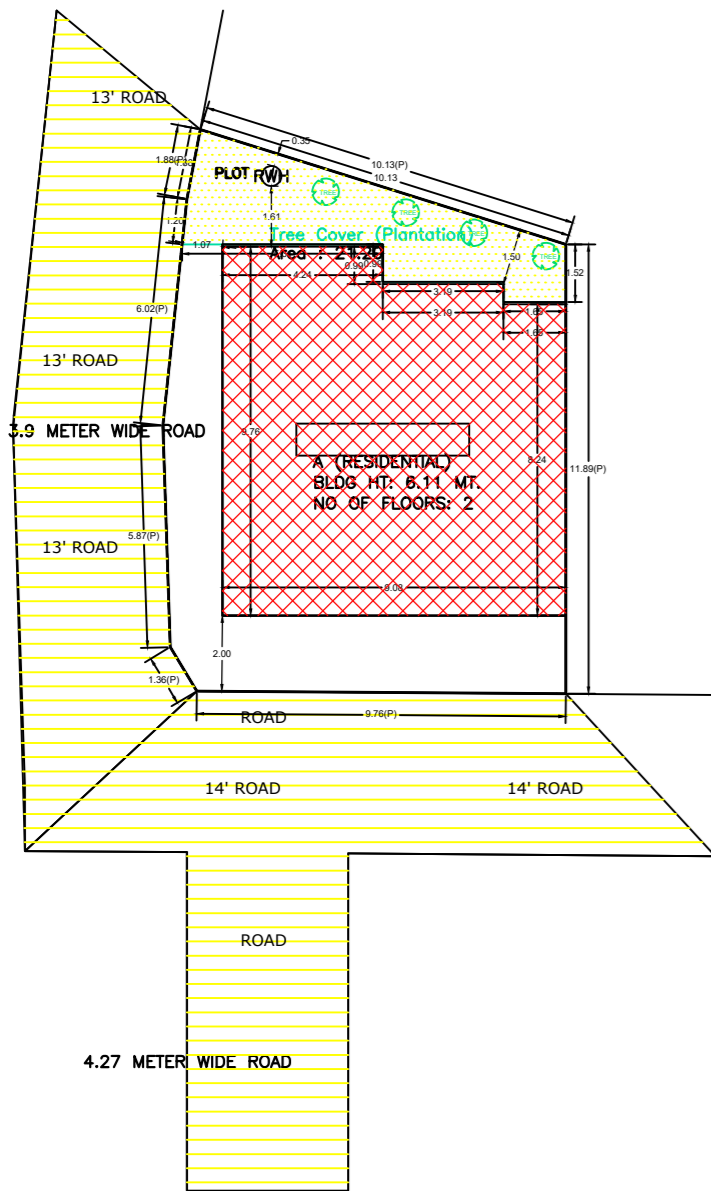

KEY PLAN (SCALE -NTS)

COLOR INDEX	
PLOT BOUNDARY	Black
ABUTTING ROAD	Green
PROPOSED CONSTRUCTION	Red
COMMON PLOT	Yellow
ROAD WIDENING AREA	Light Yellow
EXISTING (To be retained)	Blue
EXISTING (To be demolished)	Light Blue

Buildingwise Floor FAR Details

Floor Name	Building Name A (RESIDENTIAL)		Total	
	Proposed Built Up Area (Sq.mt.)	Proposed FAR Area (Sq.mt.)	Total Proposed Built Up Area (Sq.mt.)	Total FAR Area (Sq.mt.)
Ground Floor	82.99	51.52	82.99	51.52
First Floor	83.57	83.57	83.57	83.57
Terrace Floor	0.00	0.00	0.00	0.00
Total :	166.56	135.09	166.56	135.09

Building USE/SUBUSE Details

Building Name	Building Use	Building SubUse	Building Structure
A (RESIDENTIAL)	Residential	Bungalow/ Dwelling / Non Apartment	Non-Highrise

FAR & Tenement Details (Table 4c-1)

Building	No. of Same Bldg	Total Built Up Area (Sq.mt.)	Deductions (Area in Sq.mt.)	Proposed FAR Area (Sq.mt.)	Total FAR Area (Sq.mt.)	Total Consumed Additional FAR Area (Sq.mt.)	Tnmt (No.)
			Parking				
A (RESIDENTIAL)	1	166.56	31.47	135.09	135.09	135.09	01
Grand Total :	1	166.56	31.47	135.09	135.09	135.09	01

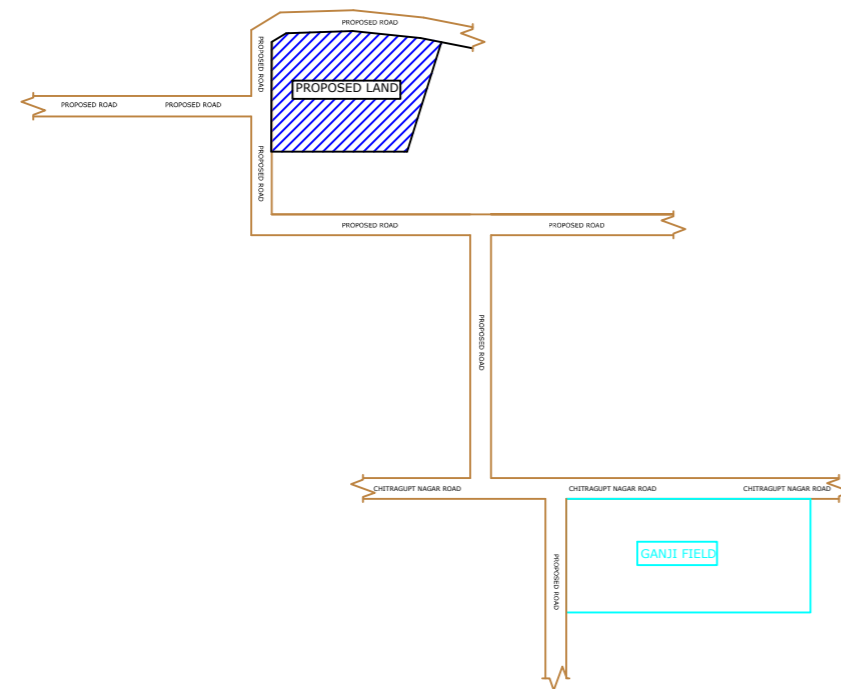

LOCATION PLAN (SCALE -1"32')

AREA STATEMENT		VERSION NO.:	1.0.69
JHUMRITILAIYA NAGAR PARISHAD		VERSION DATE: 16/10/2020	
PROJECT DETAIL:			
Region: JHARKHAND URBAN LOCAL BODIES	Plot Use: Residential		
District: KODERMA	Plot SubUse: Bungalow/ Dwelling / Non Apartment		
Authority: JHUMRITILAIYA NAGAR PARISHAD	PlotNearbyReligiousStructure: NA		
Inward_No: JNP/BP/0024/W22/2024	Plot/SubPlot No: 1222, 1220, 1227		
Application Type: General Proposal	North: Plot No. - NIJ VENDOR		
Project Type: Building Permission	South: Road Width - 4.27		
Nature of Development: New	East: Plot No. - SUSHILA DEVI		
Location of Development Area: Old Area	West: Road Width - 3.9		
AREA DETAILS:			SQ.MT.
AREA OF PLOT (Minimum)	(A)	139.42	
NET AREA OF PLOT(Gross Plot Area - Deduction from Gross Plot area)	(A-Deductions)	139.42	
Deduction for Balance Plot Area(from Gross Plot Area)			
Common Plot		21.20	
Total		21.20	
BALANCE AREA OF PLOT(Net Plot Area - Recreational/Amerity space)	(A-Deductions)	118.22	
PLOT AREA FOR COVERAGE(Net Plot Area)	(A-Deductions)	139.42	
Plot Area for FAR (Net Plot Area + RoadWidening Area)	(A-Deductions)	139.42	
COVERAGE CHECK			
Permissible Coverage area (70.00 %)		97.59	
Proposed Coverage Area (59.53 %)		83.00	
Total Prop. Coverage Area (59.53 %)		83.00	
Balance coverage area (10.46 %)		14.59	
FAR CHECK			
Perm. FAR Area (1.500)		209.13	
Total Perm. FAR area		209.13	
Residential FAR		135.10	
Proposed FAR Area		135.10	
Total Proposed FAR Area		135.10	
Consumed FAR (Factor)		0.97	
Balance FAR Area		74.03	
BUILT UP AREA CHECK			
Total Proposed BuiltUp Area		166.56	
ARCHITECT (Regd)		KIRAN KUMARI	
ENGINEER (Regd)			
SUPERVISOR (Regd)			
OWNER (Regd)		SMT PUJA KUMARI	
DEVELOPMENT AUTHORITY		LOCAL BODY	

LTP NAME AND SIGNATURE	STRUCTURAL ENG'S NAME AND SIGNATURE	BUILDER NAME AND SIGNATURE	DIGITAL SIGNATURE
KIRAN KUMARI JNP/ENG/0001/2019			

Proposal Basic Information

Proposal File No.	JNP/BP/0024/W22/2024
Owner Name	SMT PUJA KUMARI
Khata No	294, 296, 302
Plot No	1222, 1220, 1227
Village Name	Gomo
Use	Residential
SubUse	Bungalow/ Dwelling / Non Apartment

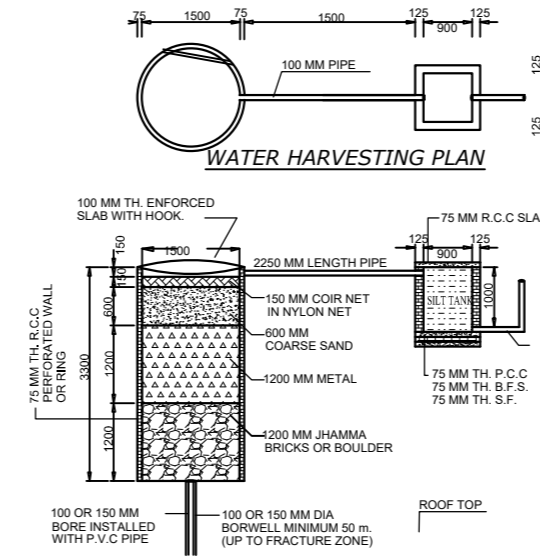
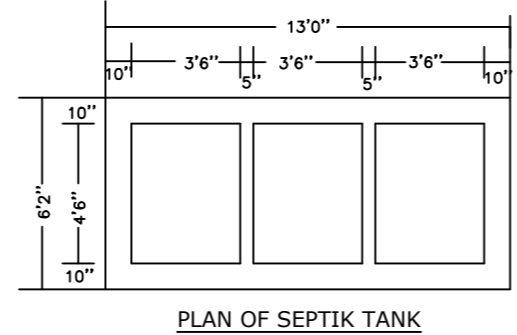
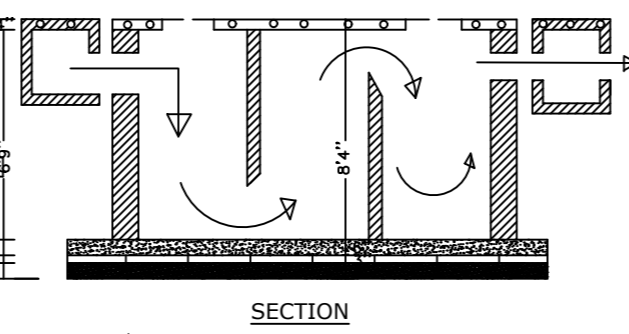
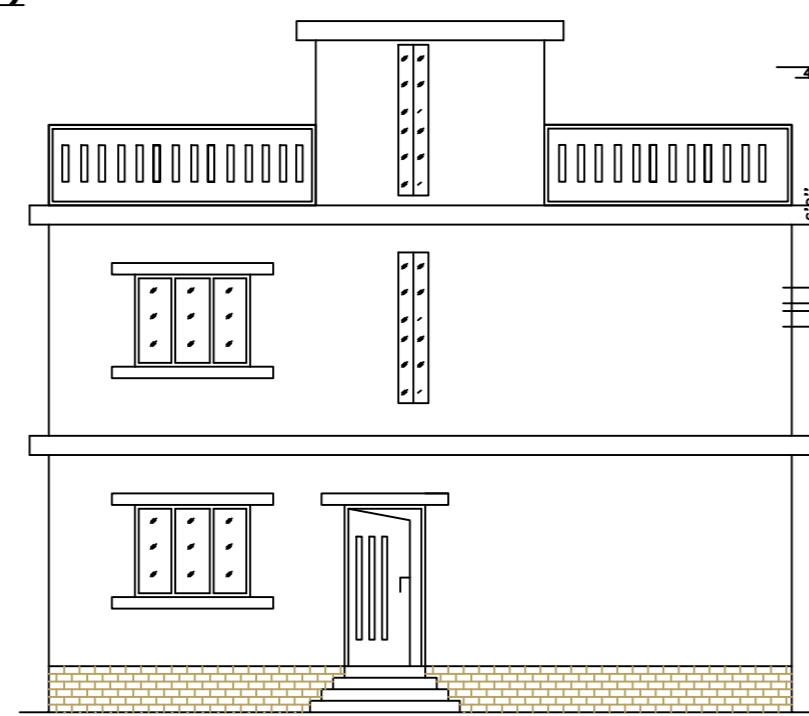
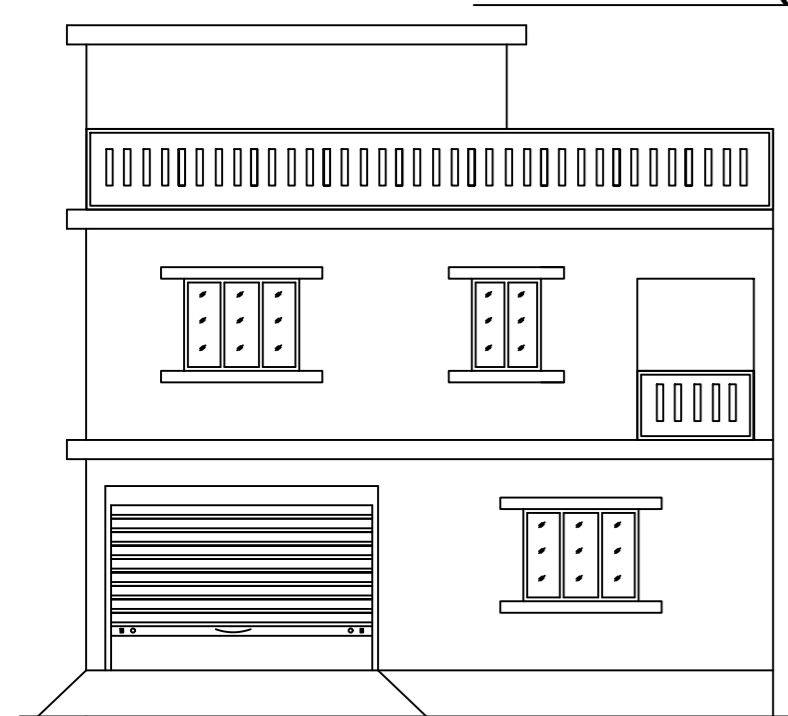
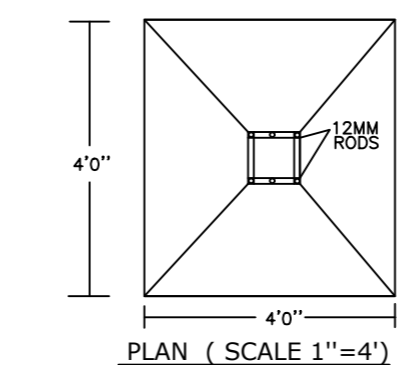
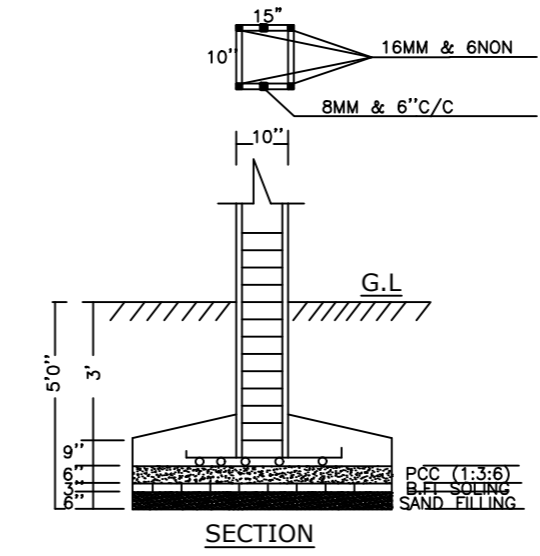
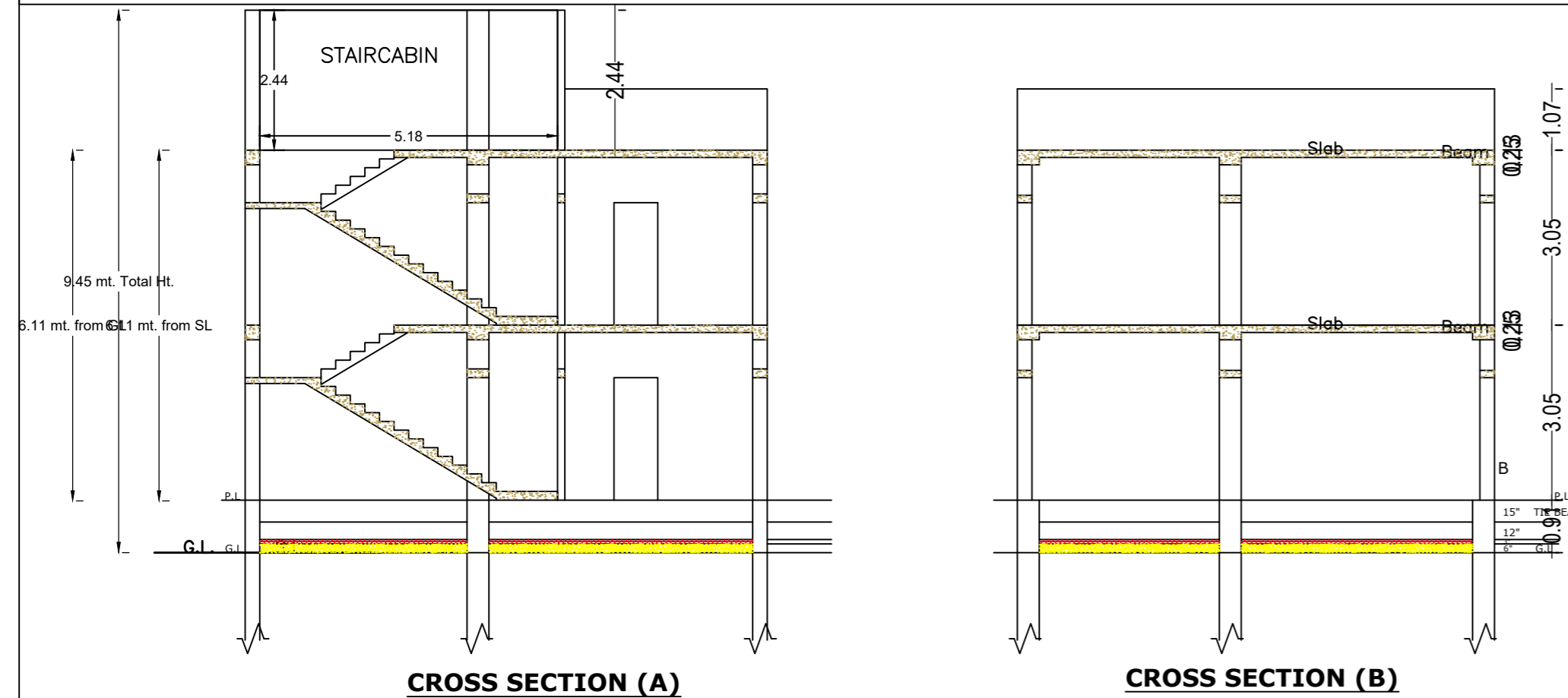

Building :A (RESIDENTIAL)

Floor Name	Total Built Up Area (Sq.mt.)	Deductions (Area in Sq.mt.)		Proposed FAR Area (Sq.mt.)	Total FAR Area (Sq.mt.)	Total Consumed Additional FAR Area (Sq.mt.)	Tnmt (No.)
		Parking	Resi.				
Ground Floor	82.99	31.47	51.52	51.52	51.52	51.52	01
First Floor	83.57	0.00	83.57	83.57	83.57	83.57	00
Terrace Floor	0.00	0.00	0.00	0.00	0.00	0.00	00
Total :	166.56	31.47	135.09	135.09	135.09	135.09	01
Total Number of Same Buildings :	1						
Total :	166.56	31.47	135.09	135.09	135.09	135.09	01

SCHEDULE OF DOOR:

BUILDING NAME	NAME	LENGTH	HEIGHT	NOS
A (RESIDENTIAL)	D2	0.75	2.10	02
A (RESIDENTIAL)	D1	0.90	2.10	01
A (RESIDENTIAL)	D	1.05	2.10	04
A (RESIDENTIAL)	SD	1.50	2.10	01

SCHEDULE OF WINDOW/VENTILATION:

BUILDING NAME	NAME	LENGTH	HEIGHT	NOS
A (RESIDENTIAL)	V	0.60	0.90	02
A (RESIDENTIAL)	W1	0.90	1.20	01
A (RESIDENTIAL)	W	1.50	1.20	04
A (RESIDENTIAL)	SD	1.50	2.10	01

UnitBUA Table for Building :A (RESIDENTIAL)

FLOOR	Name	UnitBUA Type	UnitBUA Area	Carpet Area	No. of Rooms	No. of Tenement
GROUND FLOOR PLAN	SPLIT BANGALOW	FLAT	94.21	91.51	4	1
FIRST FLOOR PLAN	SPLIT BANGALOW	FLAT	0.00	0.00	8	0
Total:	-	-	94.21	91.51	12	1

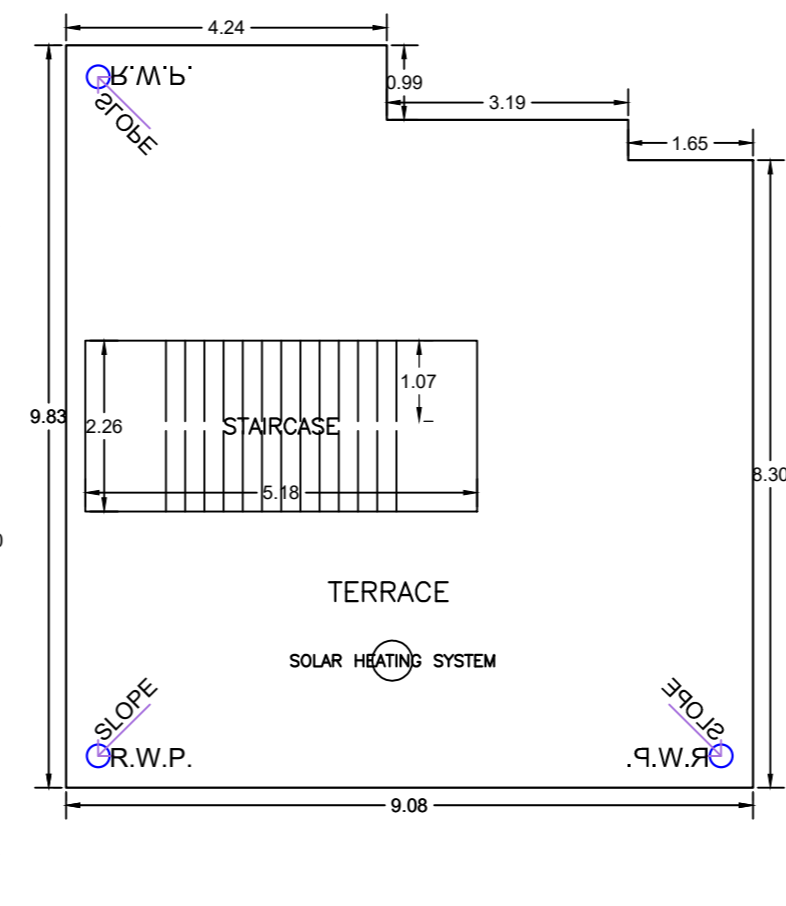
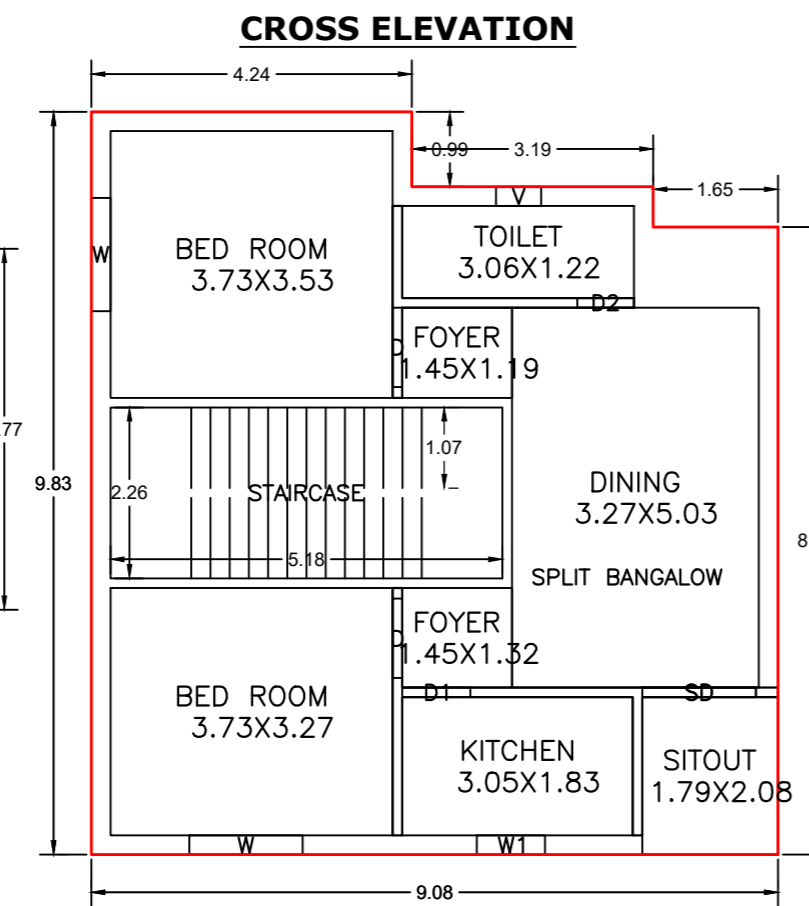
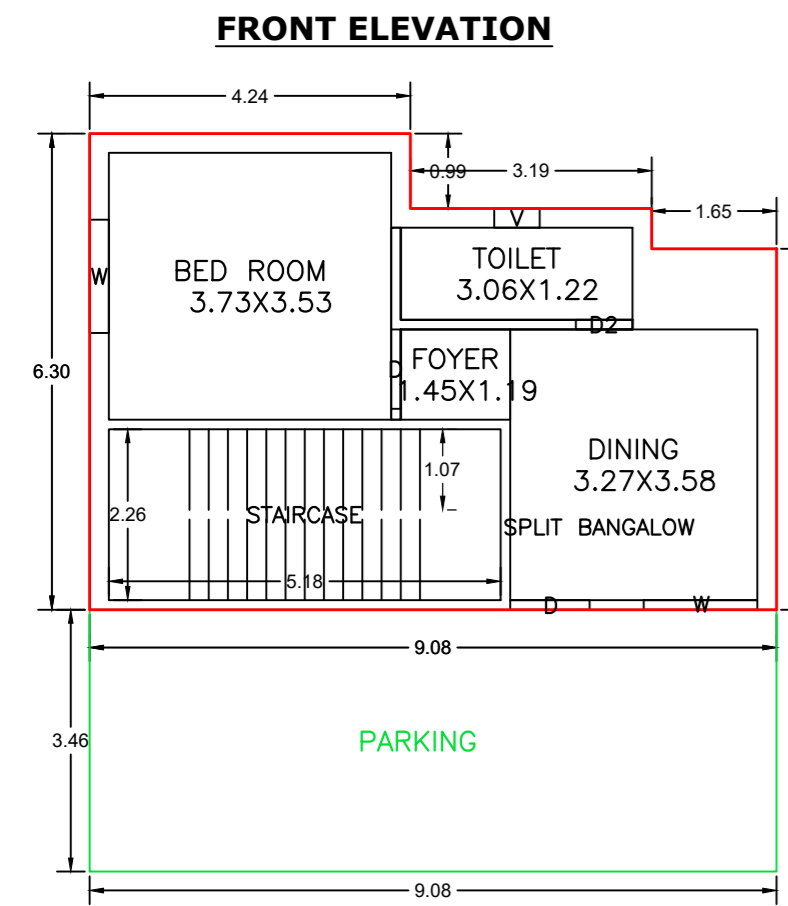

LTP NAME AND SIGNATURE	STRUCTURAL ENG'S NAME AND SIGNATURE	BUILDER NAME AND SIGNATURE	DIGITAL SIGNATURE
KIRAN KUMARI JNP/ENG/0001/2019			