

SCHEDULE OF DOOR:

BUILDING NAME	NAME	LENGTH	HEIGHT	NOS
AA (SRI DILIP KUMAR SAHU)	D2	0.75	2.10	01
AA (SRI DILIP KUMAR SAHU)	D1	0.90	2.10	01
AA (SRI DILIP KUMAR SAHU)	D	1.00	2.10	03

SCHEDULE OF WINDOW/VENTILATION:

BUILDING NAME	NAME	LENGTH	HEIGHT	NOS
AA (SRI DILIP KUMAR SAHU)	V	0.60	0.60	02
AA (SRI DILIP KUMAR SAHU)	W1	0.90	1.20	01
AA (SRI DILIP KUMAR SAHU)	W	1.50	1.20	04

UnitBUA Table for Building :AA (SRI DILIP KUMAR SAHU)

FLOOR	Name	UnitBUA Type	UnitBUA Area	Carpel Area	No. of Rooms	No. of Tenement
GROUND FLOOR PLAN	SPLIT FLAT A	FLAT	40.17	39.84	1	1
FIRST FLOOR PLAN	SPLIT FLAT A	FLAT	0.00	0.00	3	0
SECOND FLOOR PLAN	SPLIT FLAT A	FLAT	0.00	0.00	1	0
Total:	-	-	40.17	39.84	5	1

Building :AA (SRI DILIP KUMAR SAHU)

Floor Name	Total Built Up Area (Sq.mt.)	Proposed FAR Area (Sq.mt.) Resi.	Total FAR Area (Sq.mt.)	Total Consumed Additional FAR Area (Sq.mt.)	Tnmt (No.)
Ground Floor	23.52	23.52	23.52	23.52	01
First Floor	23.52	23.52	23.52	23.52	00
Second Floor	23.52	23.52	23.52	23.52	00
Terrace Floor	0.00	0.00	0.00	0.00	00
Total :	70.56	70.56	70.56	70.56	01
Total Number of Same Buildings :	1				
Total :	70.56	70.56	70.56	70.56	01

FAR & Tenement Details (Table 4c-1)

Building	No. of Same Bldg	Total Built Up Area (Sq.mt.)	Proposed FAR Area (Sq.mt.) Resi.	Total FAR Area (Sq.mt.)	Total Consumed Additional FAR Area (Sq.mt.)	Tnmt (No.)
AA (SRI DILIP KUMAR SAHU)	1	70.56	70.56	70.56	70.56	01
Grand Total :	1	70.56	70.56	70.56	70.56	01

Building USE/SUBUSE Details

Building Name	Building Use	Building SubUse	Building Structure
AA (SRI DILIP KUMAR SAHU)	Residential	Bungalow/ Dwelling / Non Apartment	Non-Highrise

Buildingwise Floor FAR Details

Floor Name	Building Name AA (SRI DILIP KUMAR SAHU)			
	Proposed Built Up Area (Sq.mt.)	Proposed FAR Area (Sq.mt.)	Total Proposed Built Up Area (Sq.mt.)	Total FAR Area (Sq.mt.)
Ground Floor	23.52	23.52	23.52	23.52
First Floor	23.52	23.52	23.52	23.52
Second Floor	23.52	23.52	23.52	23.52
Terrace Floor	0.00	0.00	0.00	0.00
Total :	70.56	70.56	70.56	70.56

COLOR INDEX

Color	Description
Black	PLOT BOUNDARY
Red	ABUTTING ROAD
Green	PROPOSED CONSTRUCTION
Blue	COMMON PLOT
Yellow	ROAD WIDENING AREA
Orange	EXISTING (To be retained)
Purple	EXISTING (To be demolished)

AREA STATEMENT	VERSION NO. : 1.0.70
JHUMRITILAIYA NAGAR PARISHAD	VERSION DATE: 16/10/2020
PROJECT DETAIL:	
Region: JHARKHAND URBAN LOCAL BODIES	Plot Use: Residential
District: KODERMA	Plot SubUse: Bungalow/ Dwelling / Non Apartment
Authority: JHUMRITILAIYA NAGAR PARISHAD	PlotNearby/ReligiousStructure: NA
Inward No: JNP/BP/0050/W/14/2024	Plot/SubPlot No: 7164
Application Type: General Proposal	North: Plot No. - ADITYA KUMAR ARYA
Project Type: Building Permission	South: Road Width - 5.18M WIDE ROAD
Nature of Development: New	East: Plot No. - NIZ VENDOR
Location of Development Area: Old Area	West: Plot No. - NIZ VENDOR
AREA DETAILS:	
AREA OF PLOT (Minimum)	(A) 40.73
NET AREA OF PLOT(Gross Plot Area - Deduction from Gross Plot area)	(A-Deductions) 40.73
Deduction for Balance Plot Area(from Gross Plot Area)	
Common Plot	4.16
Total	4.16
BALANCE AREA OF PLOT(Net Plot Area - Recreational/Amenity space)	(A-Deductions) 36.57
PLOT AREA FOR COVERAGE(Net Plot Area)	(A-Deductions) 40.73
Plot Area for FAR (Net Plot Area + RoadWidening Area)	(A-Deductions) 40.73
COVERAGE CHECK	
Permissible Coverage area (70.00 %)	28.51
Proposed Coverage Area (57.75 %)	23.52
Total Prop. Coverage Area (57.75 %)	23.52
Balance coverage area (12.25 %)	4.99
FAR CHECK	
Perm. FAR Area (1,800)	73.31
Total Perm. FAR area	73.31
Residential FAR	70.57
Proposed FAR Area	70.57
Total Proposed FAR Area	70.57
Consumed FAR (Factor)	1.73
Balance FAR Area	2.74
BUILT UP AREA CHECK	
Total Proposed BuiltUp Area	70.56
ARCHITECT (Regd)	MD SHOAB ALAM
ENGINEER (Regd)	
SUPERVISOR (Regd)	SRI DILIP KUMAR SAHU
OWNER (Regd)	
DEVELOPMENT AUTHORITY LOCAL BODY	

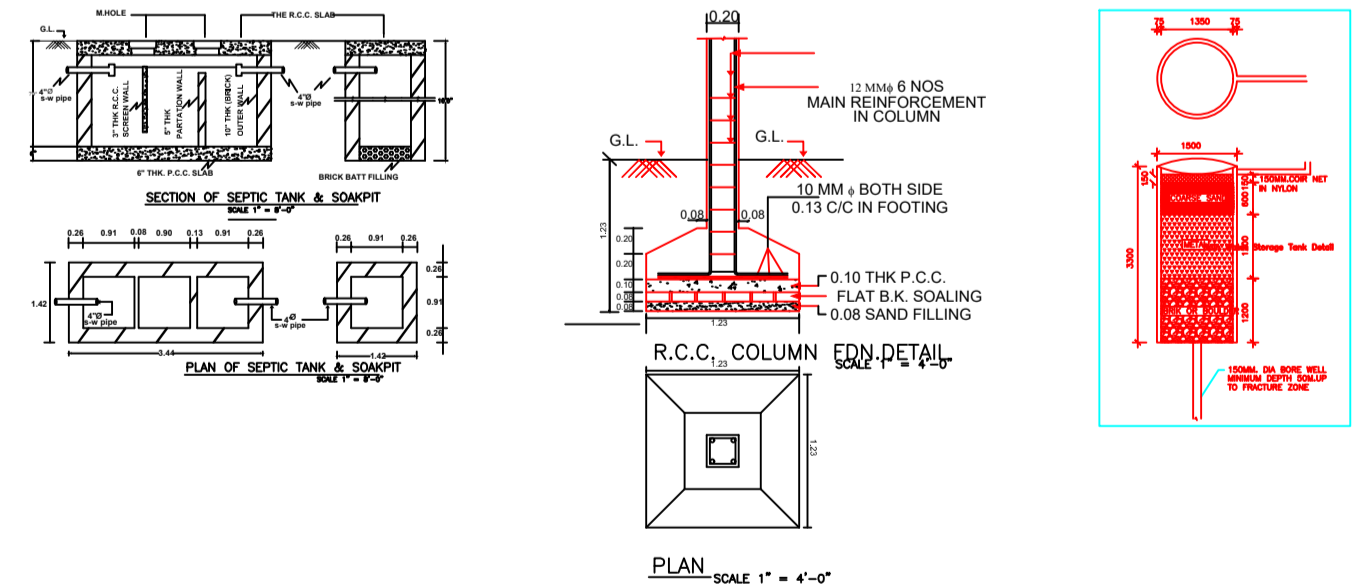

LTP NAME AND SIGNATURE	STRUCTURAL ENG'S NAME AND SIGNATURE	BUILDER NAME AND SIGNATURE	DIGITAL SIGNATURE
MD SHOAB ALAM JNP/ENG/0001/2017			