

SITE PLAN

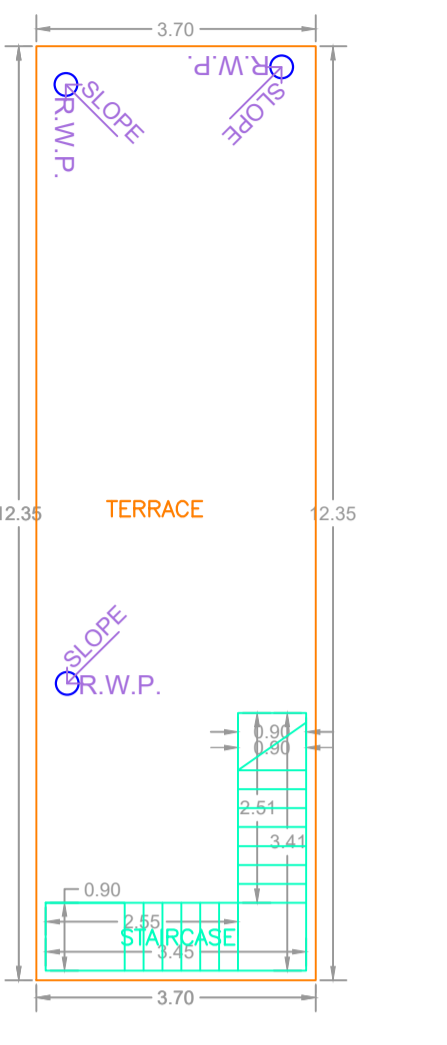

TERRACE FLOOR PLAN (SCALE 1:100)

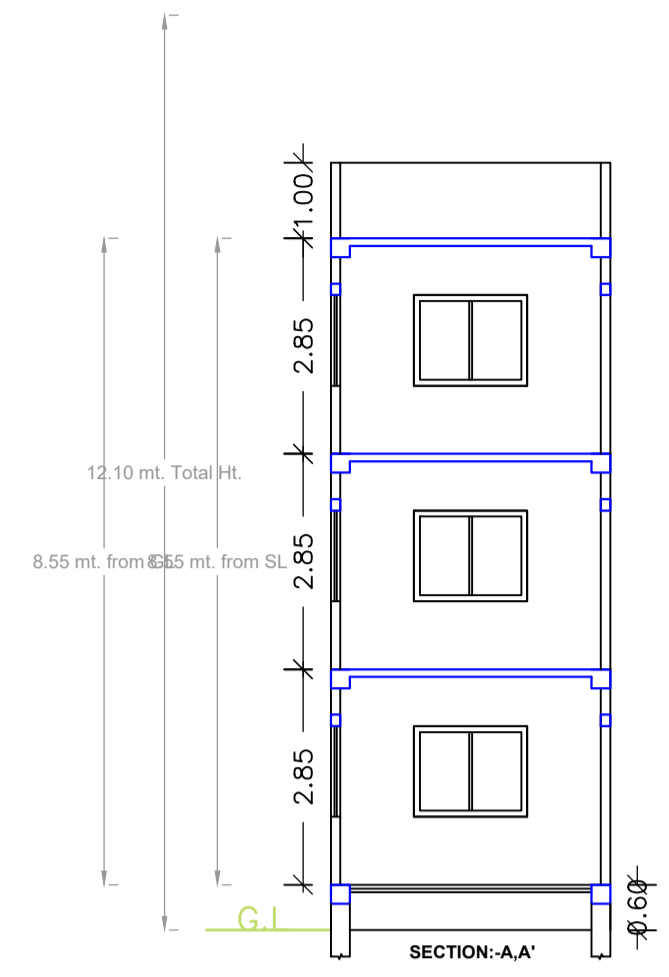

SECTION-AA'

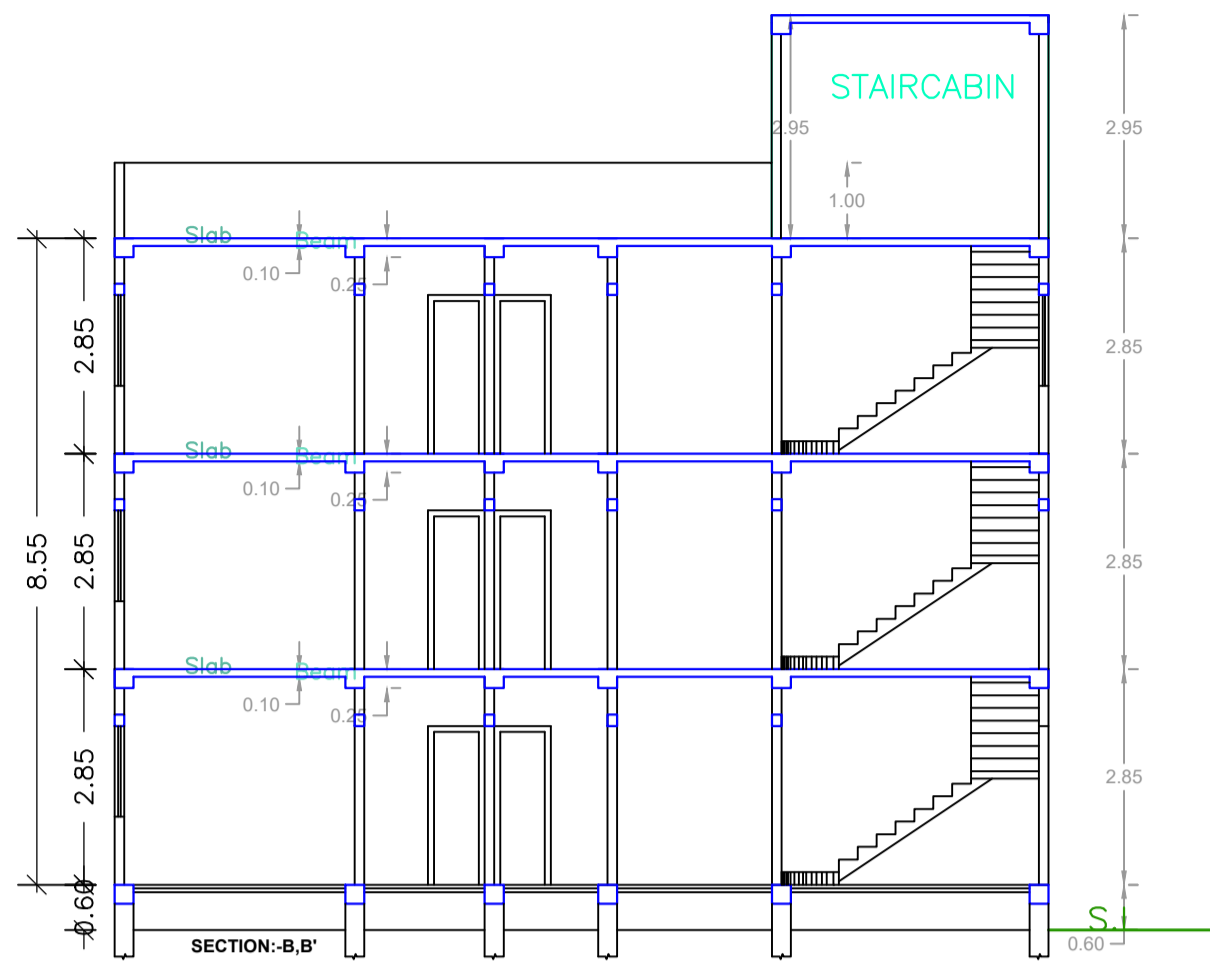

SECTION-B-B'

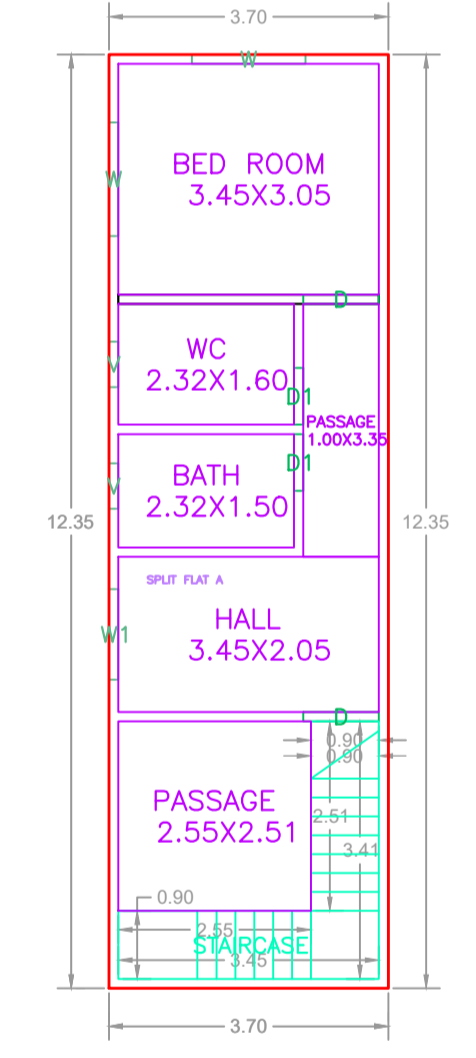

GROUND FLOOR PLAN (Proposed) (SCALE 1:100)

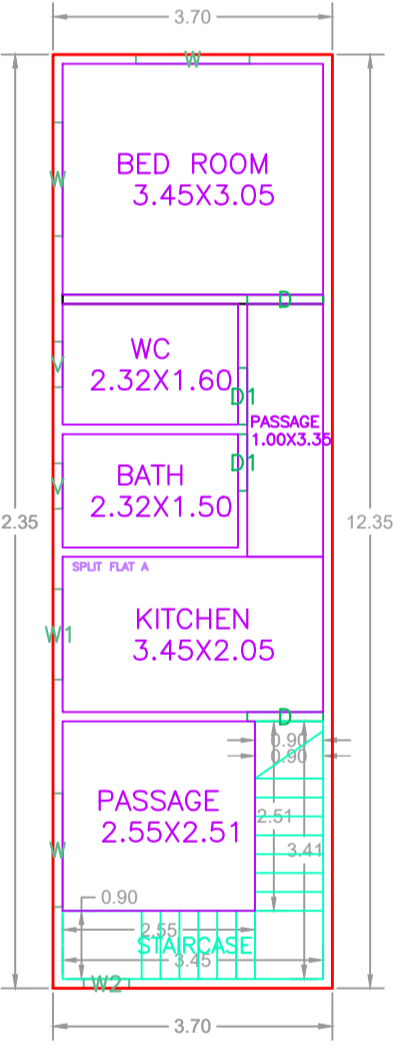

TYPICAL - 1& 2 FLOOR PLAN (Proposed) (SCALE 1:100)

Building :AA (SRI BHARAT PRASAD)

Floor Name	Total Built Up Area (Sq.mt.)	Proposed FAR Area (Sq.mt.)	Total FAR Area (Sq.mt.)	Total Consumed Additional FAR Area (Sq.mt.)	Tnmt (No.)
Ground Floor	45.65	45.65	45.65	45.65	01
First Floor	45.65	45.65	45.65	45.65	00
Second Floor	45.65	45.65	45.65	45.65	00
Terrace Floor	0.00	0.00	0.00	0.00	00
Total :	136.95	136.95	136.95	136.95	01
Total Number of Same Buildings	1				
Total :	136.95	136.95	136.95	136.95	01

SCHEDULE OF DOOR:

BUILDING NAME	NAME	LENGTH	HEIGHT	NOS
AA (SRI BHARAT PRASAD)	D1	0.75	2.10	06
AA (SRI BHARAT PRASAD)	D	1.00	2.10	06

SCHEDULE OF WINDOW/VENTILATION:

BUILDING NAME	NAME	LENGTH	HEIGHT	NOS
AA (SRI BHARAT PRASAD)	V	0.60	0.60	06
AA (SRI BHARAT PRASAD)	W2	0.60	1.20	02
AA (SRI BHARAT PRASAD)	W1	1.20	1.20	03
AA (SRI BHARAT PRASAD)	W	1.50	1.20	08

UnitBUA Table for Building :AA (SRI BHARAT PRASAD)

FLOOR	Name	UnitBUA Type	UnitBUA Area	Carpet Area	No. of Rooms	No. of Tenement
GROUND FLOOR PLAN	SPLIT FLAT A	FLAT	108.70	107.41	6	1
TYPICAL - 1& 2 FLOOR PLAN	SPLIT FLAT A	FLAT	0.00	0.00	6	0
Total:	-	-	108.70	107.41	18	1

Building USE/SUBUSE Details

Building Name	Building Use	Building SubUse	Building Structure	Floor Name	Floor Use	Floor SubUse	FAR Name	FAR Use	FAR SubUse
AA (SRI BHARAT PRASAD)	Residential	Bungalow/ Dwelling / Non Apartment	Non-Highrise	GROUND FLOOR PLAN	Residential	Bungalow/ Dwelling / Non Apartment	Residential FAR	Residential	Bungalow/ Dwelling / Non Apartment
				TYPICAL - 1& 2 FLOOR PLAN	Residential	Bungalow/ Dwelling / Non Apartment	Residential FAR	Residential	Bungalow/ Dwelling / Non Apartment
				TERRACE FLOOR PLAN	Residential	Bungalow/ Dwelling / Non Apartment	-	-	-

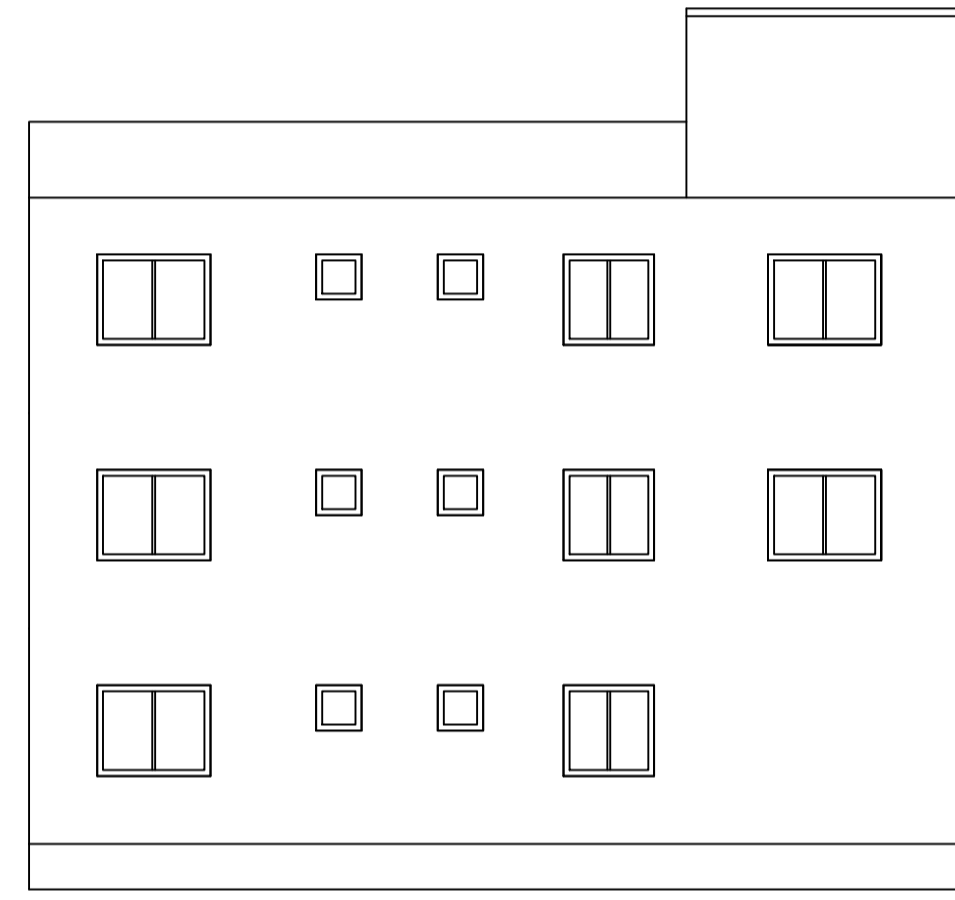

SIDE ELEVATION

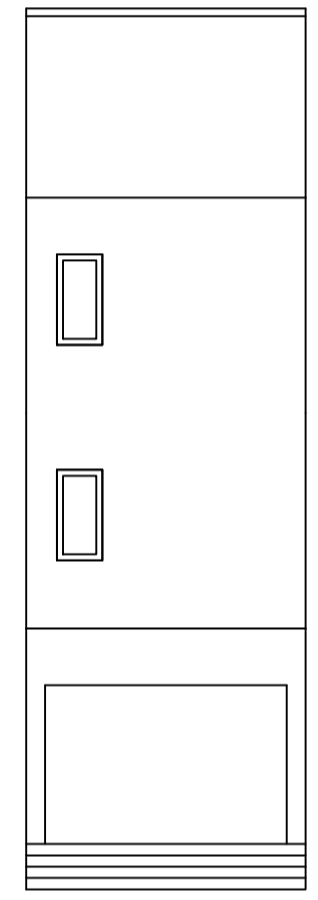

FRONT ELEVATION

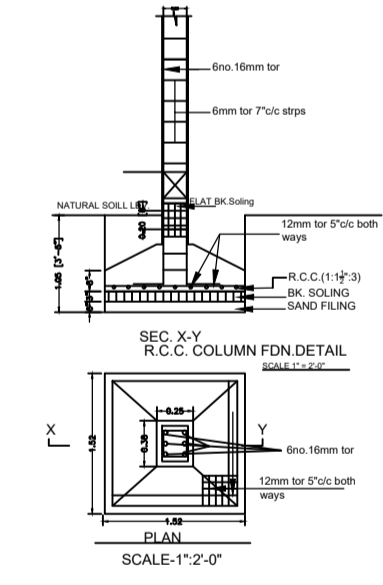

SITE KEY PLAN NOT TO SCALE

AREA STATEMENT		VERSION NO. : 1.0.73
JHUMRITILAIYA NAGAR PARISHAD		VERSION DATE: 16/10/2020
PROJECT DETAIL:		
Region: JHARKHAND URBAN LOCAL BODIES	Plot Use: Residential	
District: KODERMA	Plot SubUse: Bungalow/ Dwelling / Non Apartment	
Authority: JHUMRITILAIYA NAGAR PARISHAD	PlotNearbyReligiousStructure: NA	
Inward No: JNP/IBP/0085/W13/2024	PlotSubPlot No: 6893	
Application Type: General Proposal	North: Plot No. - SRI SANJAY KUMAR MODI	
Project Type: Building Permission	South: Plot No. - SRI SURAJ SINGH	
Nature of Development: New	East: Road Width - 6.10M WIDE ROAD	
Location of Development Area: Old Area	West: Plot No. - DIWAL BAD TAPESHWAR SINGH	
AREA DETAILS:		
AREA OF PLOT (Minimum)	(A)	SQ.MT. 75.15
NET AREA OF PLOT(Gross Plot Area - Deduction from Gross Plot area)	(A-Deductions)	75.15
Deduction for Balance Plot Area(from Gross Plot Area)		
Common Plot		5.97
Total		5.97
BALANCE AREA OF PLOT(Net Plot Area - Recreational/Amenity space)	(A-Deductions)	69.18
PLOT AREA FOR COVERAGE(Net Plot Area)	(A-Deductions)	75.15
Plot Area for FAR (Net Plot Area + RoadWidening Area)	(A-Deductions)	75.15
COVERAGE CHECK		
Permissible Coverage area ( 70.00 % )		52.60
Proposed Coverage Area ( 60.75 % )		45.65
Total Prop. Coverage Area ( 60.75 % )		45.65
Balance coverage area ( 9.25 % )		6.95
FAR CHECK		
Perm. FAR Area ( 2.000 )		150.30
Total Perm. FAR area		150.30
Residential FAR		136.96
Proposed FAR Area		136.96
Total Proposed FAR Area		136.96
Consumed FAR (Factor)		1.82
Balance FAR Area		13.34
BUILT UP AREA CHECK		
Total Proposed BuiltUp Area		136.95
ARCHITECT (Regd)		MD SYEED ALAM ANSARI
ENGINEER (Regd)		
SUPERVISOR (Regd)		
OWNER (Regd)		SRI BHARAT PRASAD
DEVELOPMENT AUTHORITY		LOCAL BODY

COLOR INDEX	
PLOT BOUNDARY	Black
ABUTTING ROAD	Green
PROPOSED CONSTRUCTION	Red
COMMON PLOT	Yellow
ROAD WIDENING AREA	Blue
EXISTING (To be retained)	Orange
EXISTING (To be demolished)	Grey

Buildingwise Floor FAR Details

Floor Name	Building Name		Total	
	Proposed Built Up Area (Sq.mt.)	Proposed FAR Area (Sq.mt.)	Total Proposed Built Up Area (Sq.mt.)	Total FAR Area (Sq.mt.)
Ground Floor	45.65	45.65	45.65	45.65
First Floor	45.65	45.65	45.65	45.65
Second Floor	45.65	45.65	45.65	45.65
Terrace Floor	0.00	0.00	0.00	0.00
Total :	136.95	136.95	136.95	136.95

FAR & Tenement Details (Table 4c-1)

Building	No. of Same Bldg	Total Built Up Area (Sq.mt.)	Proposed FAR Area (Sq.mt.)	Total FAR Area (Sq.mt.)	Total Consumed Additional FAR Area (Sq.mt.)	Tnmt (No.)
AA (SRI BHARAT PRASAD)	1	136.95	136.95	136.95	136.95	01
Grand Total :	1	136.95	136.95	136.95	136.95	01

LTP NAME AND SIGNATURE	STRUCTURAL ENG'S NAME AND SIGNATURE	BUILDER NAME AND SIGNATURE	DIGITAL SIGNATURE
MD SYEED ALAM ANSARI JNP/ARC/003/2017			