

Building USE/SUBUSE Details

Building Name	Building Use	Building SubUse	Building Structure
A (SMT LAGAIN DEVI)	Residential		Non-Highrise

COLOR INDEX	
PLOT BOUNDARY	[Red Line]
ABUTTING ROAD	[Green Line]
PROPOSED CONSTRUCTION	[Blue Line]
COMMON PLOT	[Yellow Line]
ROAD WIDENING AREA	[Orange Line]
EXISTING (To be retained)	[Light Blue Line]
EXISTING (To be demolished)	[Light Yellow Line]

AREA STATEMENT		VERSION NO.: 1.0.24
LOHARDAGA NAGAR PARISHAD		VERSION DATE: 30/03/2018
PROJECT DETAIL:		
Region: JHARKHAND URBAN LOCAL BODIES	Plot Use: Residential	
District: LOHARDAGA	Plot SubUse: Residential Bldg/Apartment	
Authority: LOHARDAGA NAGAR PARISHAD	PlotNearby/ReligiousStructure: NA	
Inward No: LNP/BP/0006/W2/12018	Plot/SubPlot No: 1244	
Application Type: General Proposal	North: -	
Project Type: Building Permission	South: -	
Nature of Development: New	East: -	
Location of Development Area: Old Area	West: -	
AREA DETAILS:		SQ.MT.
AREA OF PLOT (Minimum)	(A)	390.54
Deduction for NetPlot Area		
Surrender Free of Cost		21.42
Total		21.42
NET AREA OF PLOT(Gross Plot Area - Deduction from Gross Plot area)	(A-Deductions)	369.12
Deduction for Balance Plot Area(from Gross Plot Area)		
Surrender Free of Cost		21.42
Common Plot		42.91
Total		64.33
BALANCE AREA OF PLOT(Net Plot Area - Recreational/Amenity space)	(A-Deductions)	326.21
PLOT AREA FOR COVERAGE(Net Plot Area)	(A-Deductions)	369.12
Plot Area for FAR (Net Plot Area + Road/Widening Area)	(A-Deductions)	390.54
COVERAGE CHECK		
Permissible Coverage area (60.00 %)		221.47
Proposed Coverage Area (29.06 %)		107.26
Total Prop. Coverage Area (29.06 %)		107.26
Balance coverage area (30.94 %)		114.21
FAR CHECK		
Perm. FAR Area (2.00)		781.08
Total Perm. FAR area		781.08
Residential FAR		107.26
Proposed FAR Area		107.26
Total Proposed FAR Area		107.26
Consumed FAR (Factor)		0.27
Balance FAR Area		673.82
BUILT UP AREA CHECK		
Total Proposed BuiltUp Area		107.26
ARCHITECT (Regd)		
ASHWINI KUMAR SAHU		
ENGINEER (Regd)		
SUPERVISOR (Regd)		
OWNER (Regd)		
SMT LAGAIN DEVI		
DEVELOPMENT AUTHORITY		
LOCAL BODY		

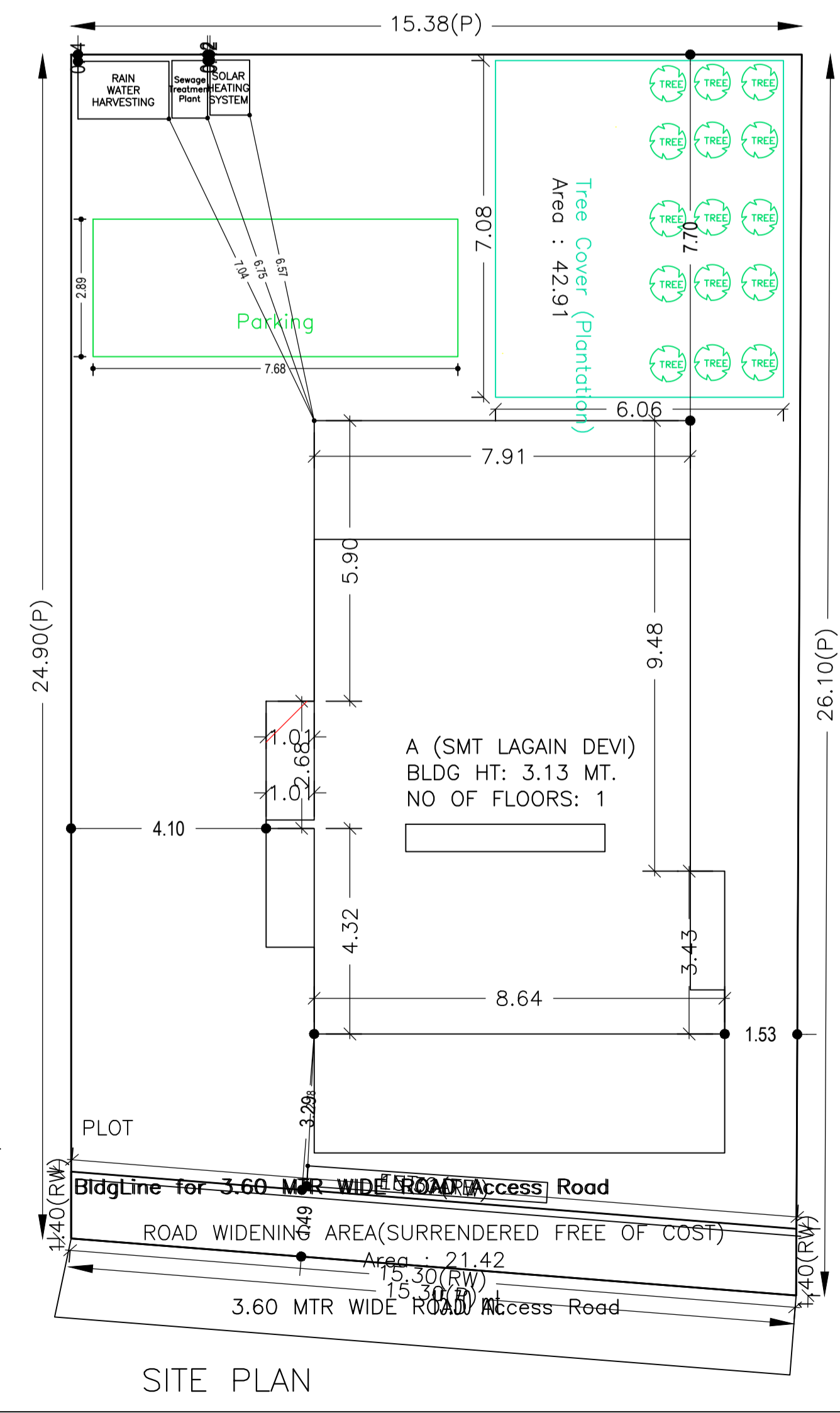
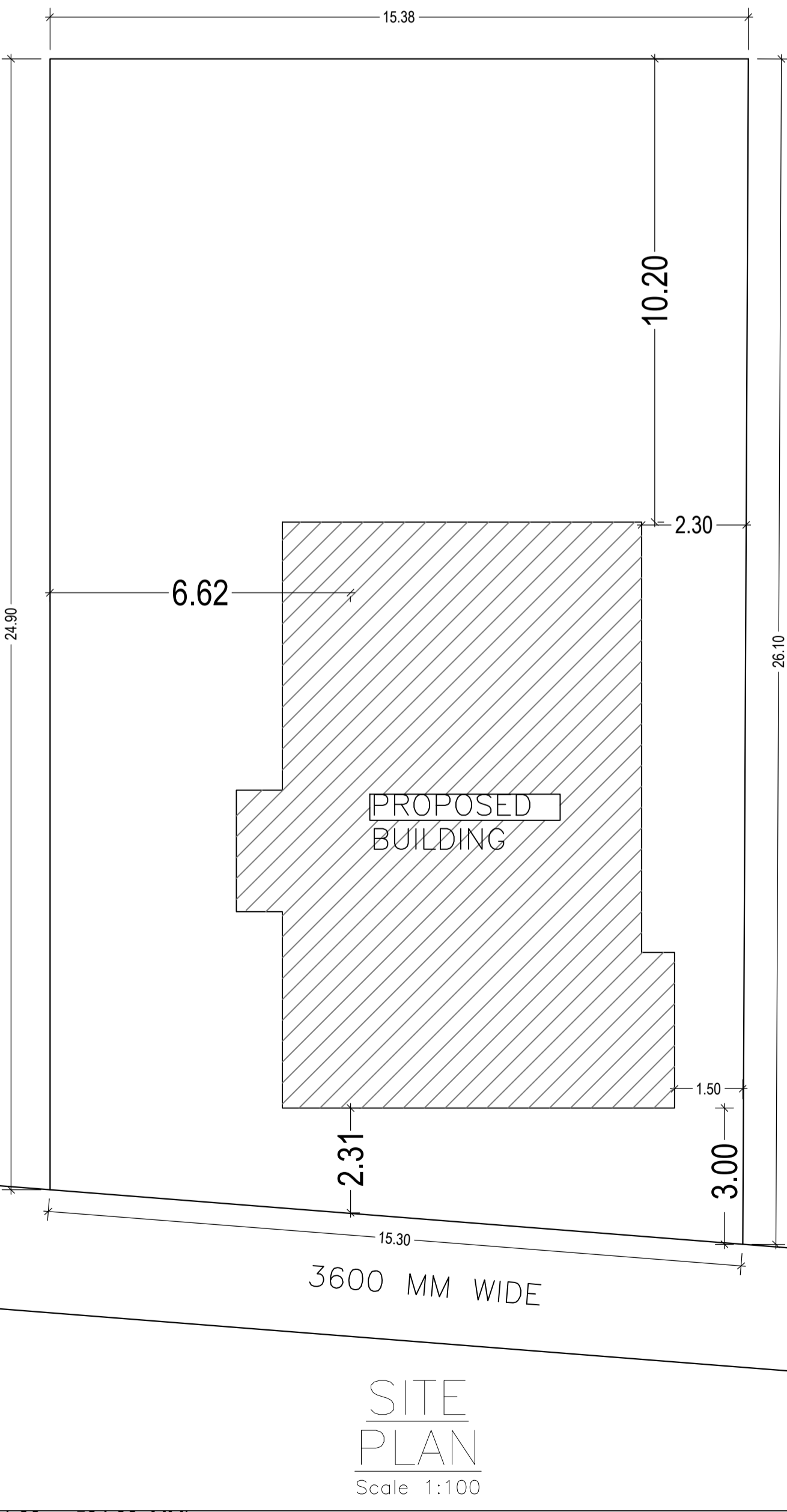
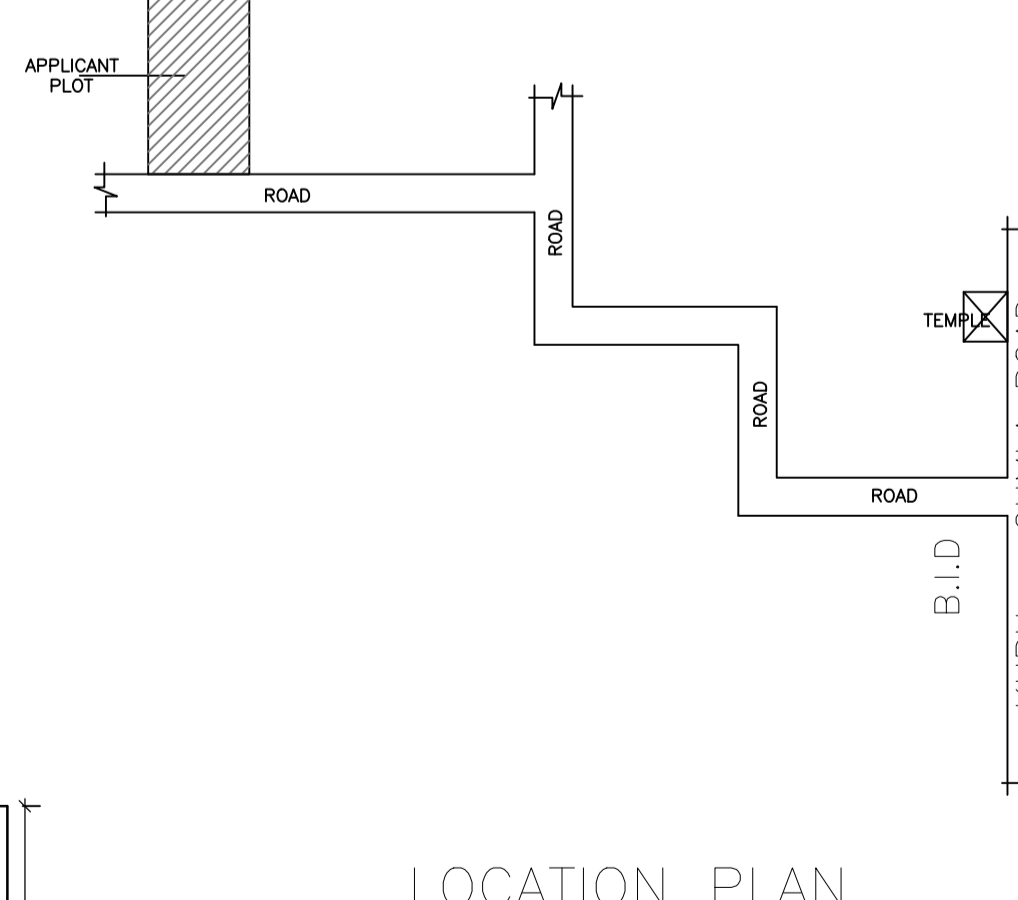
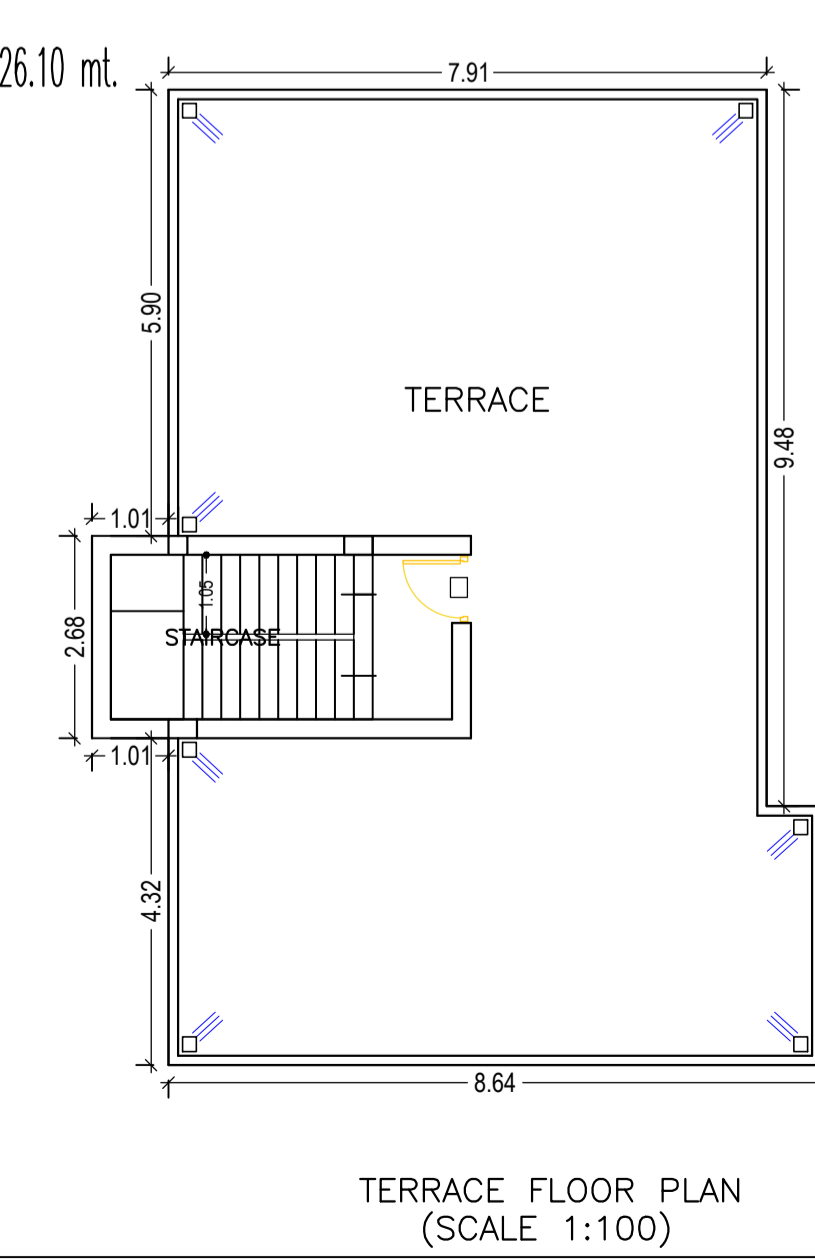
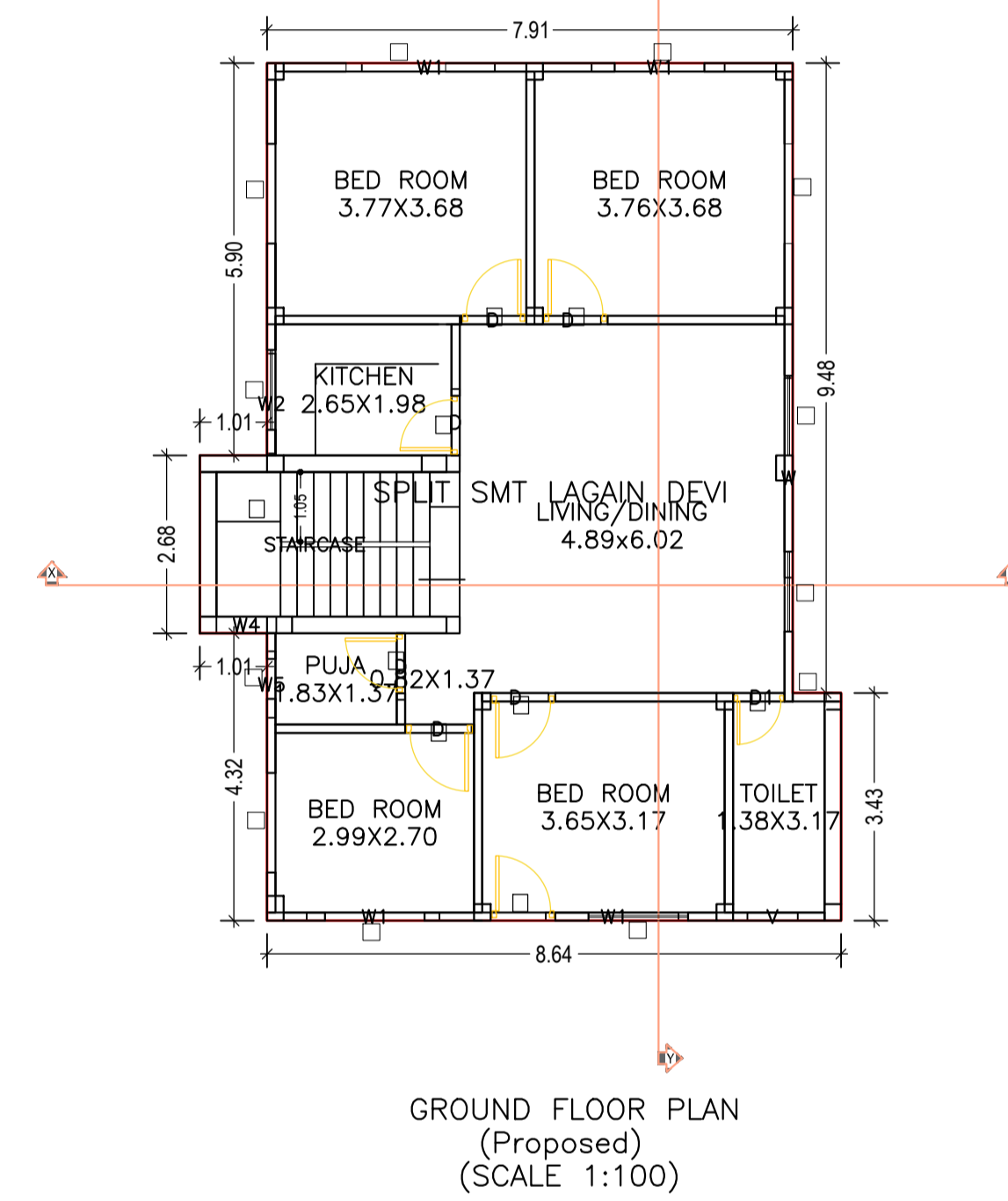
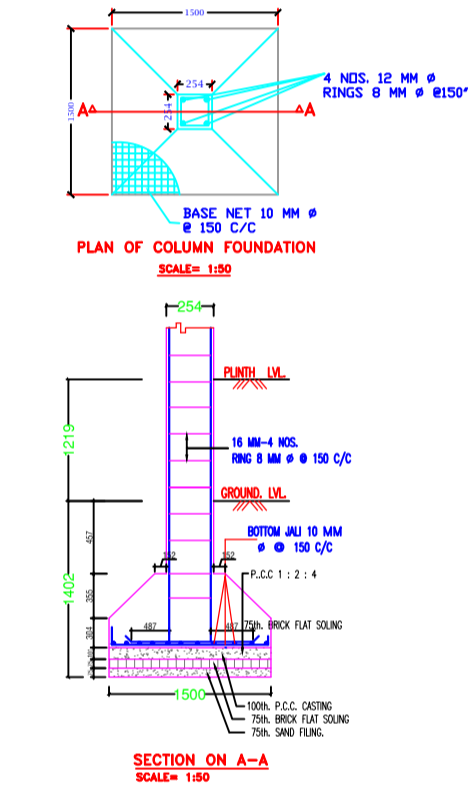
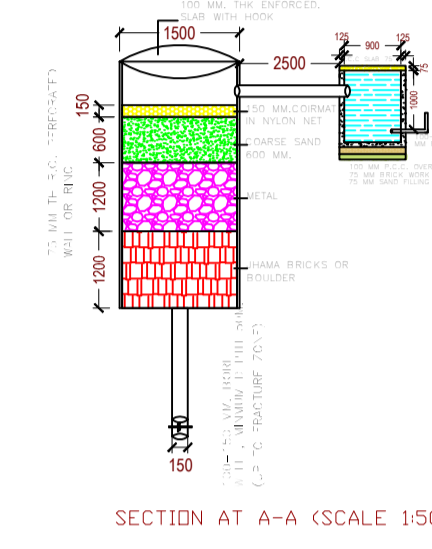
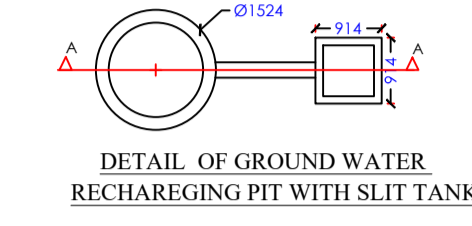
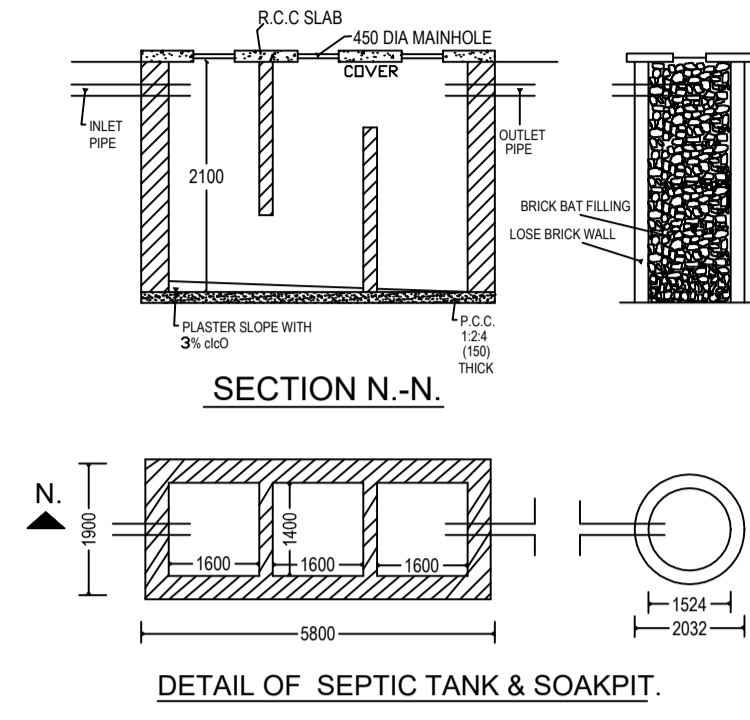
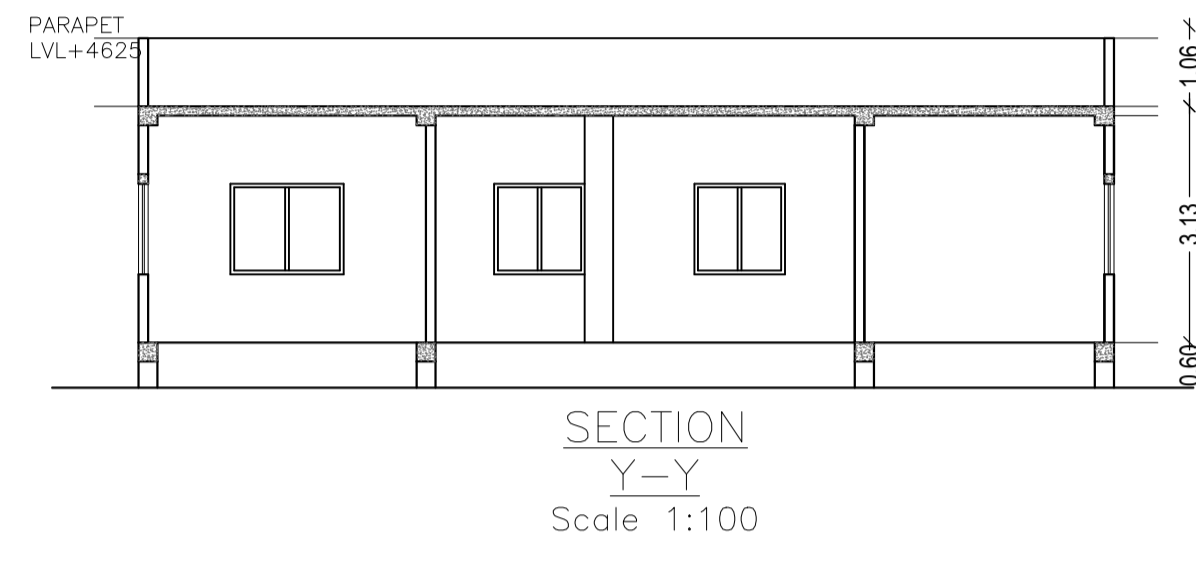
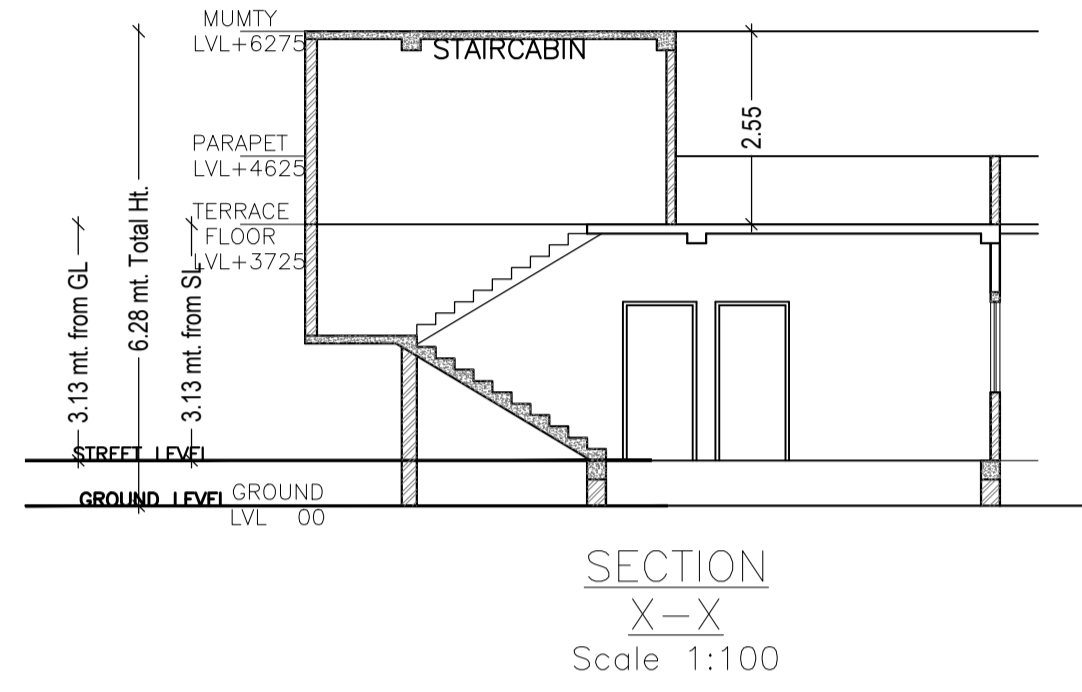
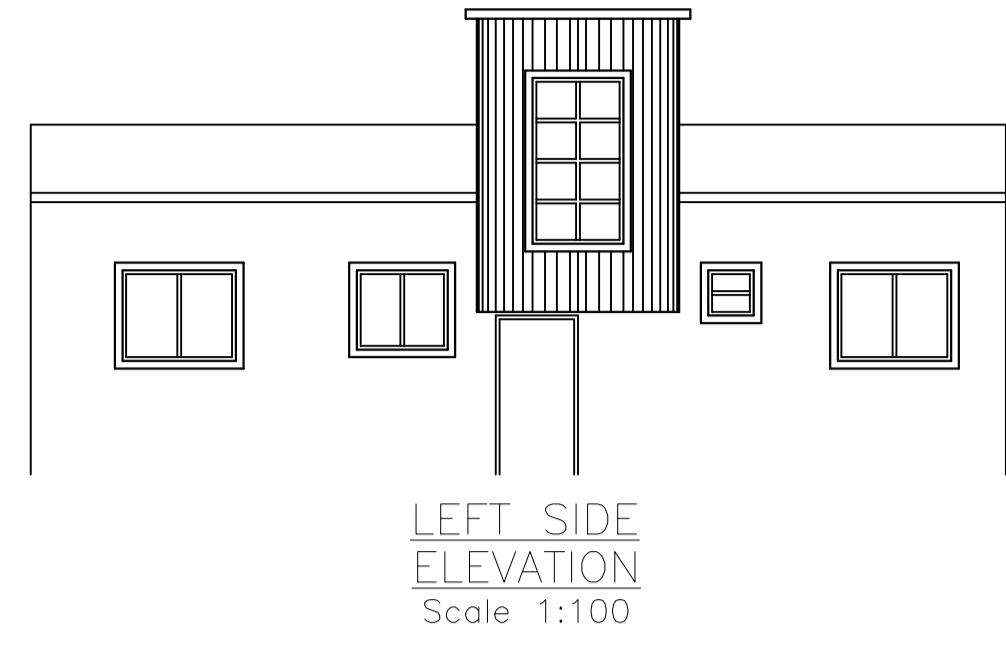
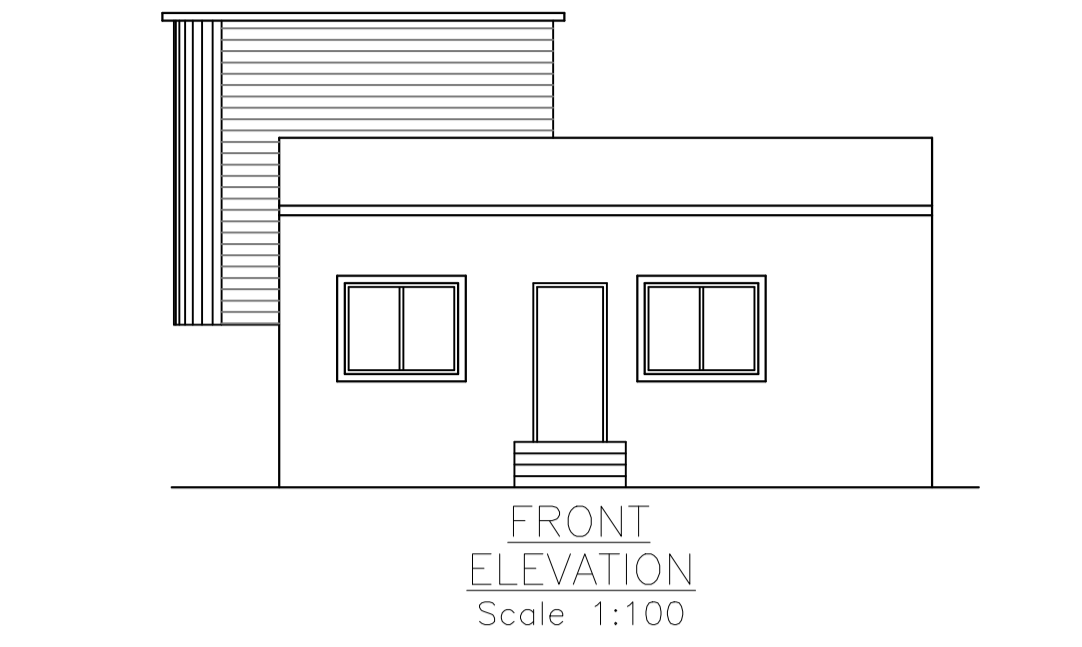

SCHEDULE OF DOOR:

BUILDING NAME	NAME	LENGTH	HEIGHT	NOS
A (SMT LAGAIN DEVI)	D1	0.76	2.13	01
A (SMT LAGAIN DEVI)	D	1.00	2.13	06

SCHEDULE OF WINDOW/VENTILATION:

BUILDING NAME	NAME	LENGTH	HEIGHT	NOS
A (SMT LAGAIN DEVI)	V	0.76	0.76	01
A (SMT LAGAIN DEVI)	W4	0.90	2.50	01
A (SMT LAGAIN DEVI)	W5	1.00	2.50	01
A (SMT LAGAIN DEVI)	W2	1.50	2.50	01
A (SMT LAGAIN DEVI)	W1	2.00	2.50	04
A (SMT LAGAIN DEVI)	W	3.00	2.50	01

Building :A (SMT LAGAIN DEVI)

Floor Name	Total Built Up Area (Sq.mt.)	Proposed FAR Area (Sq.mt.) Resi.	Total FAR Area (Sq.mt.)		
Ground Floor	107.26	107.26	107.26		01
Terrace Floor	0.00	0.00	0.00	0.00	00
Total:	107.26	107.26	107.26	107.26	01
Total Number of Same Buildings	1				
Total:	107.26	107.26	107.26	107.26	01

UnitBUA Table for Building :A (SMT LAGAIN DEVI)

FLOOR	Name	UnitBUA Type	UnitBUA Area	Carpet Area	No. of Rooms	No. of Tenement
GROUND FLOOR PLAN	SPLIT SMT LAGAIN DEVI	FLAT	91.41	87.83	8	1
Total:	-	-	91.41	87.83	8	1

Buildingwise Floor FAR Details

Floor Name	Building Name		Total	
	Proposed Built Up Area (Sq.mt.)	Proposed FAR Area (Sq.mt.)	Total Proposed Built Up Area (Sq.mt.)	Total FAR Area (Sq.mt.)
Ground Floor	107.26	107.26	107.26	107.26
Terrace Floor	0.00	0.00	0.00	0.00
Total:	107.26	107.26	107.26	107.26

FAR & Tenement Details (Table 4c-1)

Building	No. of Same Bldg	Total Built Up Area (Sq.mt.)	Proposed FAR Area (Sq.mt.) Resi.	Total FAR Area (Sq.mt.)	Total Consumed Additional FAR Area (Sq.mt.)	Tnmt (No.)
A (SMT LAGAIN DEVI)	1	107.26	107.26	107.26	107.26	01
Grand Total:	1	107.26	107.26	107.26	107.26	01

LTP NAME AND SIGNATURE	STRUCTURAL ENG'S NAME AND SIGNATURE	BUILDER NAME AND SIGNATURE
ASHWINI KUMAR SAHU LNP/ENG/0005/2017		