

Project Title :SHRI BRIJMOHAN PRASAD SAHU

AREA STATEMENT LOHARDAGA NAGAR PARISHAD		VERSION NO. :- 1.0	VERSION DATE :- 06/05/2018
PROJECT DETAIL:			
Project No. :-	PROJ-18/2018	Plot Use :- Residential	
Region :-	JHARKHAND URBAN LOCAL BODIES	Plot Size :- Residential Body/Apartment	
District :-	LOHARDAGA	Land Use Zone :- NA	
Application Type :-	General Purpose	Building Block (BIB) :-	
Project Type :-	Building Permission	Plot No. :-	
Name of Development :-	New	Approval Survey No./Survey No. :-	
Location :-	Old Area	Thana No. :-	
Sub Location :-	NA	Ward No. :-	
Ward/Municipal Name :-		North :-	
Block No. :-		South :-	
Address :-		East :-	
		West :-	

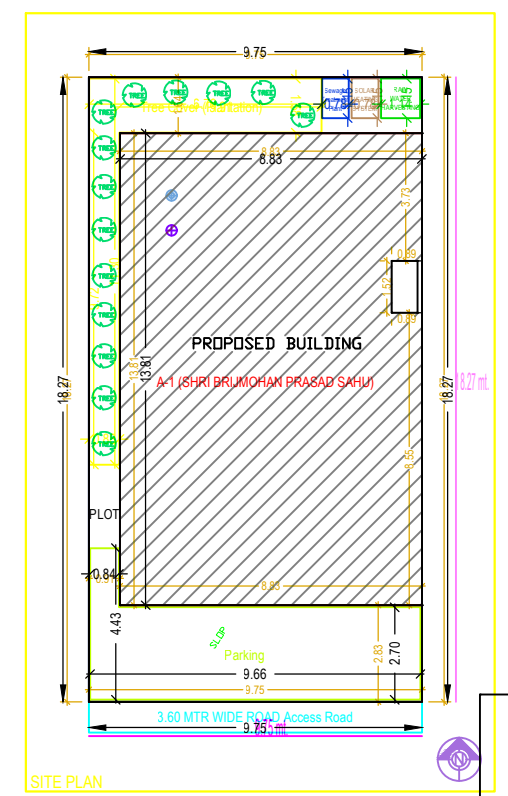
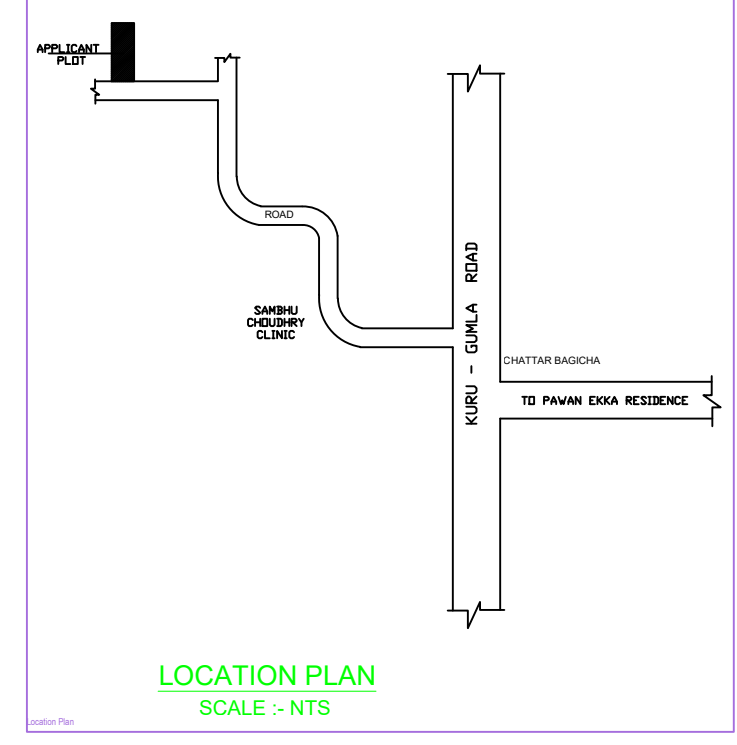
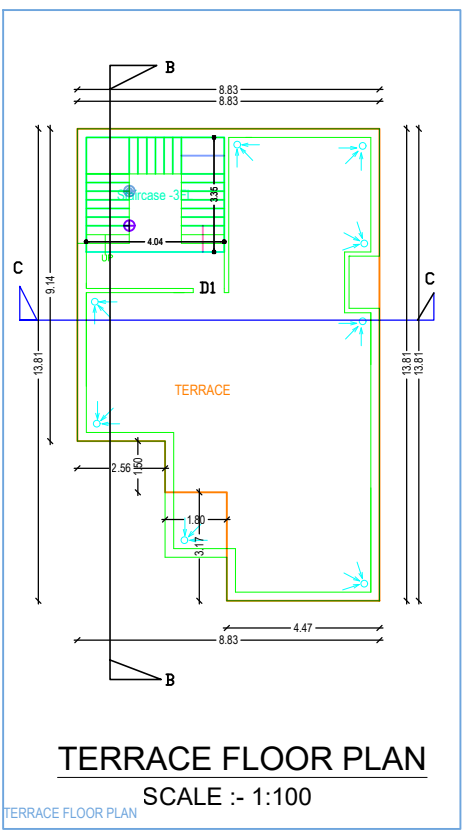
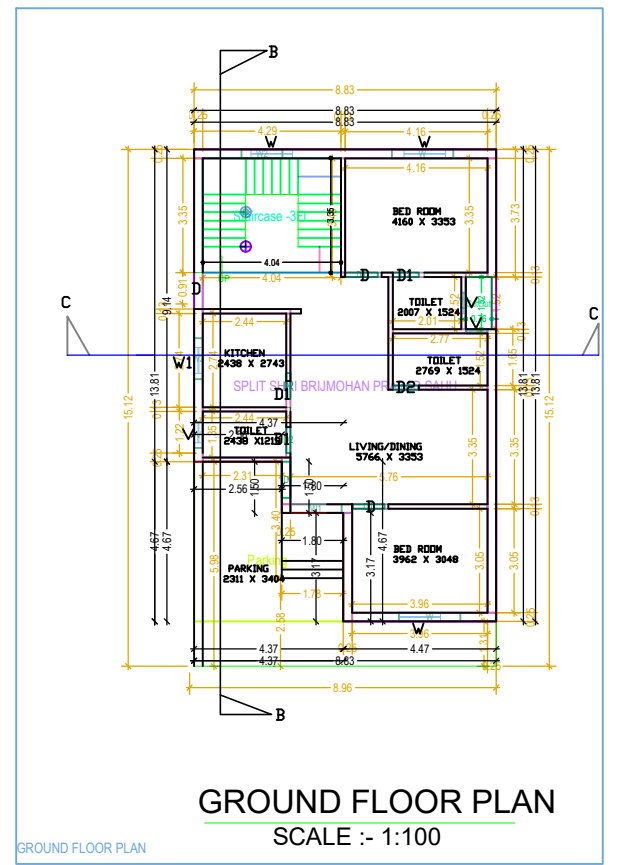
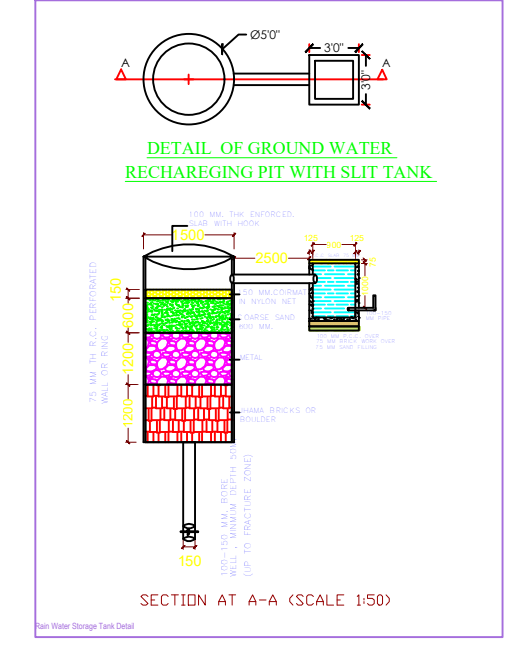
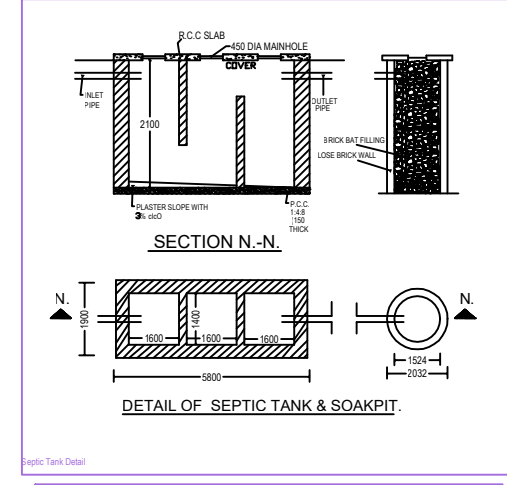
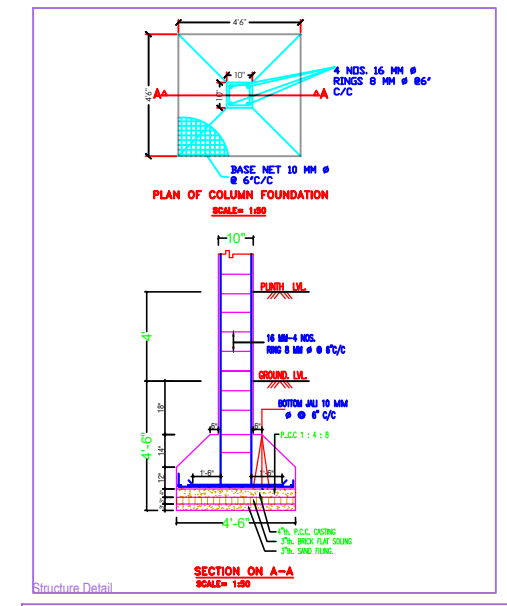
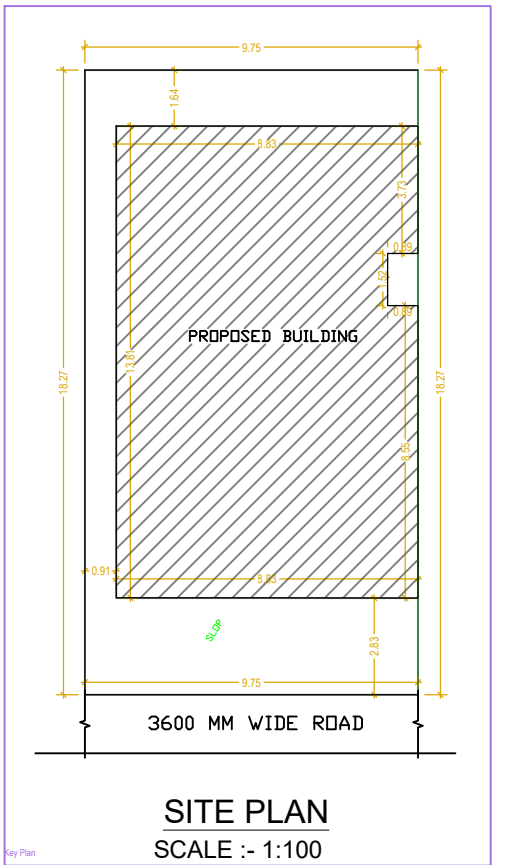
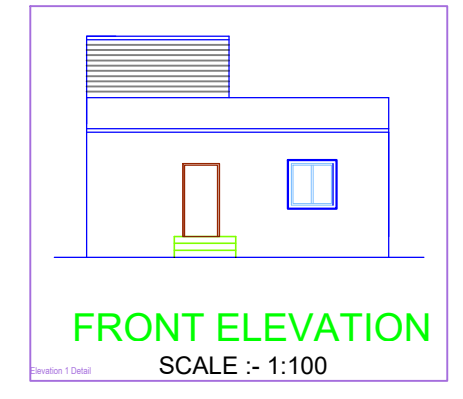
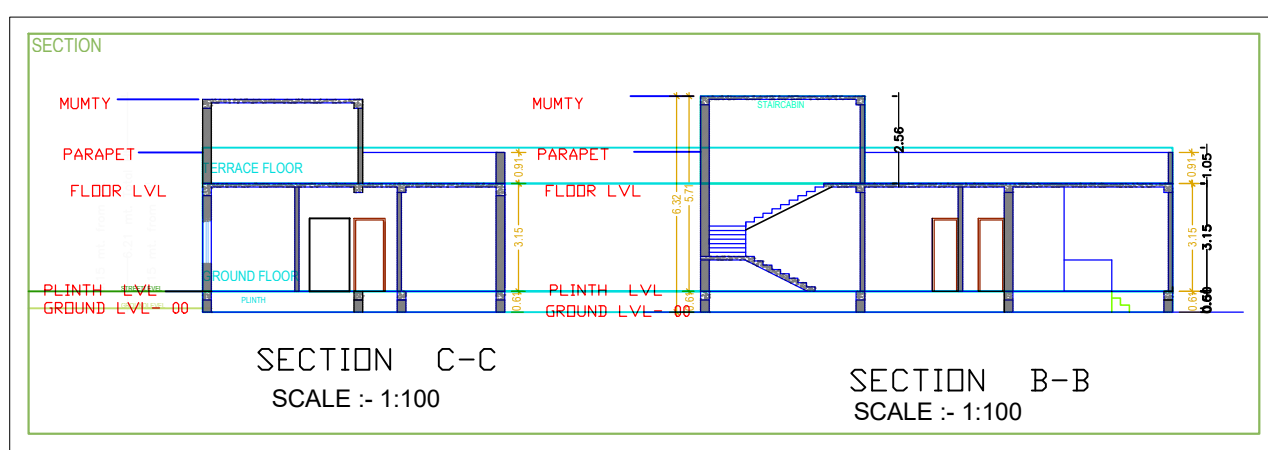

General notes	
1	ALL DIMENSION ARE IN MILLIMETERS UNLESS OTHERWISE STATED.
2	NO DIMENSION IS TO BE SCALED OFF THE DRAWING.
3	DRAWINGS TO BE READ IN CONJUNCTION WITH ALL RELEVANT DRAWINGS & SPECIFICATIONS.
4	REFER WRITTEN DIMENSIONS ONLY.
5	DOORS AND WINDOW FRAME NOT TO BE FIXED ALONG WITH BRICK WORK.
6	INTERNAL PLASTER SHOULD BE 12MM THICK AND EXTERNAL PLASTER IS 25MM THICK.
7	FOUNDATION DEPTH UP TO GOOD SOIL.
8	CEMENT MORTAR OF MIX (1:4) FOR ENTIRE STRUCTURE AND PLASTER WORK.
9	SEPTIC TANK WILL BE FLUSHING SYSTEM.
10	ALL REINFORCEMENT SHALL BE OF STEEL OF GRADE FY-415.
11	GRADE OF CONCRETE SHALL BE M-20

TYPE	WIDTH	HEIGHT	SILL LVL	DISCRPTION
D	3'6"	7'0"	NILL	SINGLE SHUTTER ELEM SHOR
D1	3'3"	7'0"	NILL	--
D2	3'0"	7'0"	NILL	--
D3	2'6"	7'0"	NILL	--
CG	5'0"	7'0"	NILL	STEEL CHANNEL GATE
W	5'0"	4'0"	3'0"	4 LEAF GLAZED WIND
W2	4'0"	4'0"	3'0"	--
W3	3'0"	4'0"	3'0"	--
V	2'0"	1'0"	8'0"	VENTILATOR

Schedule of area	
PLOT AREA AS PER DEED	178.43 SQMT
AREA OF GROUND FLOOR	122.18 SQM
TOTAL BUILT UP AREA	122.18 SQMT
%ag OF AREA COVERED	68.84
TOTAL F.A.R. ACHIEVED	0.68

PROPOSED RESIDENTIAL BUILDING PLAN OF SHRI BRIJMOHAN PRASAD SAHU, S/O. SRI MAHESH SAHU, PLOT NO. - 1201/1202, KHATA NO. 166/177, THANA NO. -194, WARD NO. -22, AREA - DECIMAL, VILLAGE - LOHARDAGA, DIST - LOHARDAGA - 835302, STATE - JHARKHAND

AREA DETAILS		UNIT	AMT
AREA OF PLOT (BHAMON)	(Sq)		178.11
NET PLOT Area Gross PLOT Area	(A-Deductions)		178.11
Deductions for Balance Plot Area from Gross PLOT Area			19.32
Plot Area			158.79
Balance Plot Area Net PLOT Area	(A-Deductions)		158.79
Recreational (Amenity space)	(A-Deductions)		178.11
PLOT AREA TO BE COVERED (NET PLOT AREA) + ROAD (WATERING AREA)	(A-Deductions)		178.11
Accession Area			3.90
COVERED AREA			122.80
Proposed Coverage Area (B.F.R. %)			122.80
Plot Coverage Area (B.F.R. %)			122.80
FAR CHECK			122.18
Proposed Area of FAR			122.18
Plot Area of FAR			122.18
BUILT UP AREA CHECK			122.80
Plot Proposed BUILT UP AREA			122.80
ARCHITECT SUPERVISOR (Sign)		OWNER	

COLOR INDEX	
PILOT BOUNDARY	Black
ABUTTING ROAD	Red
PROPOSED WORK COVERAGE AREA	Green
EXISTING (To be retained)	Blue
EXISTING (To be demolished)	Yellow

PARKING CALCULATION	
Parking Type	Prop Area
Other Parking	2
Total Area	45.28

FAR & Terment Details (Table 4c-1)								
Building	No. of Same Bldg	Gross Built Up Area (Sq.m)	Deductions From Gross Built Up Area (Sq.m)	Total Built Up Area (Sq.m)	Deductions Area (Sq.m)	Proposed FAR Area (Sq.m)	Total FAR Area (Sq.m)	Tent (No.)

Building 'A' (SHRI BRIJMOHAN PRASAD SAHU)							
FLOOR Name	Gross Built Up Area	Deductions From Gross Built Up Area (Sq.m)	Total Built Up Area (Sq.m)	Deductions Area (Sq.m)	Proposed FAR Area (Sq.m)	Total FAR Area (Sq.m)	Tent (No.)
Ground Floor	121.96	1.16	120.80	17.60	103.11	103.11	01
Terrace	3.00	0.00	3.00	0.00	3.00	0.00	00
TOTAL	121.96	1.16	120.80	17.60	103.11	103.11	01

SCHEDULE OF JOINERY:				
BUILDING NAME	NAME	LENGTH	HEIGHT	NOIS
A SHRI BRIJMOHAN PRASAD SAHU	D2	0.76	2.13	04
A SHRI BRIJMOHAN PRASAD SAHU	D3	0.65	2.13	02
A SHRI BRIJMOHAN PRASAD SAHU	D	1.05	2.13	01
A SHRI BRIJMOHAN PRASAD SAHU	W	-	-	07

SCHEDULE OF JOINERY:				
BUILDING NAME	NAME	LENGTH	HEIGHT	NOIS
A SHRI BRIJMOHAN PRASAD SAHU	V1	0.45	1.00	02
A SHRI BRIJMOHAN PRASAD SAHU	V	0.76	1.00	01
A SHRI BRIJMOHAN PRASAD SAHU	W2	1.20	2.50	02
A SHRI BRIJMOHAN PRASAD SAHU	W1	1.00	2.70	01
A SHRI BRIJMOHAN PRASAD SAHU	W	1.80	2.50	02
TOTAL				08

UnBUA Table for Building 'A' (SHRI BRIJMOHAN PRASAD SAHU)						
FLOOR	Name	UnBUA Type	UnBUA Area	Cover Area	No. of Rooms	No. of Tenement
GROUND FLOOR PLAN	SHRI BRIJMOHAN PRASAD SAHU	FLAT	78.72	78.09	1	1
TOTAL			78.72	78.09	1	1