

FRONT ELEVATION

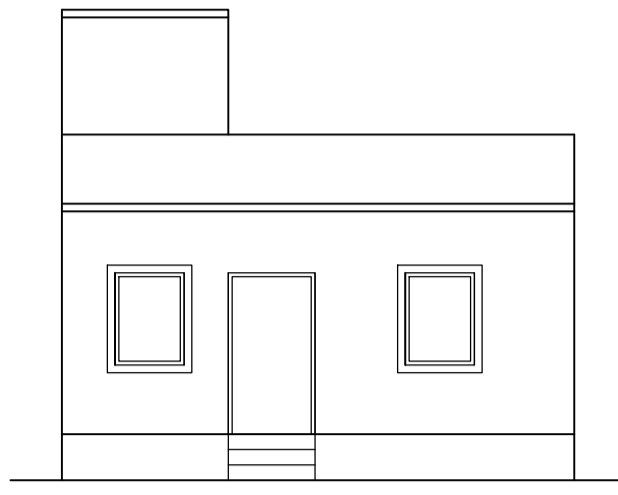

BACK ELEVATION

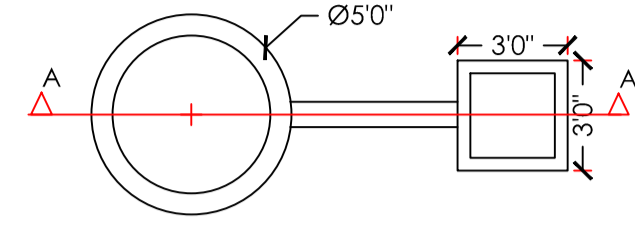

DETAIL OF GROUND WATER RECHARGING PIT WITH SLIT TANK

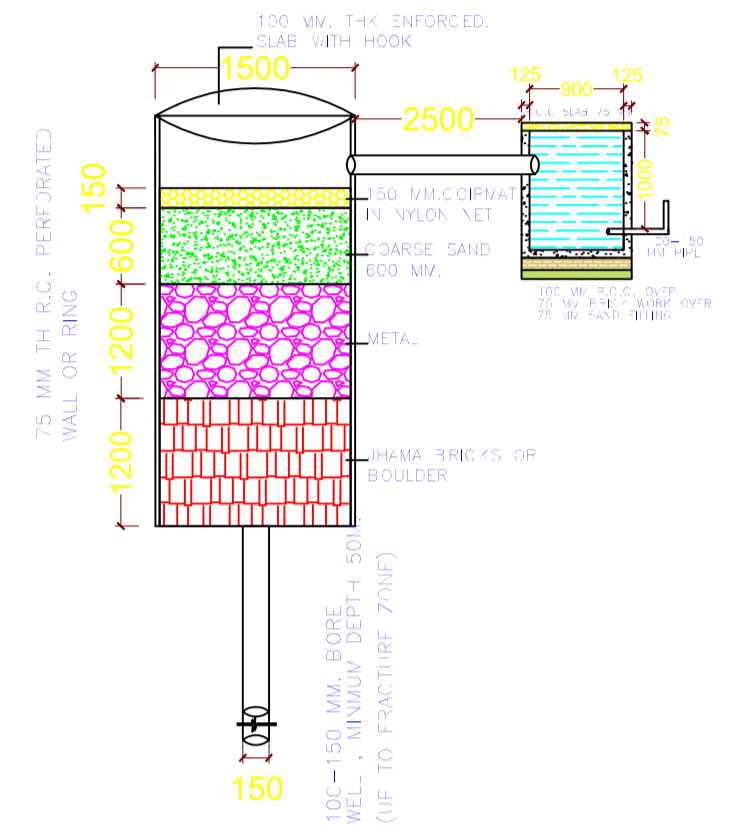

SECTION AT A-A (SCALE 1:50)

COLOR INDEX	
PLOT BOUNDARY	
ABUTTING ROAD	
PROPOSED CONSTRUCTION	
COMMON PLOT	
ROAD WIDENING AREA	
EXISTING (To be retained)	
EXISTING (To be demolished)	

UnitBUA Table for Building :A (MD NASIM AKHTAR)

FLOOR	Name	UnitBUA Type	UnitBUA Area	Carpet Area	No. of Rooms	No. of Tenement
GROUND FLOOR PLAN	SPLIT MD NASIM AKHTAR	FLAT	44.76	42.85	5	1
Total:	-	-	44.76	42.85	5	1

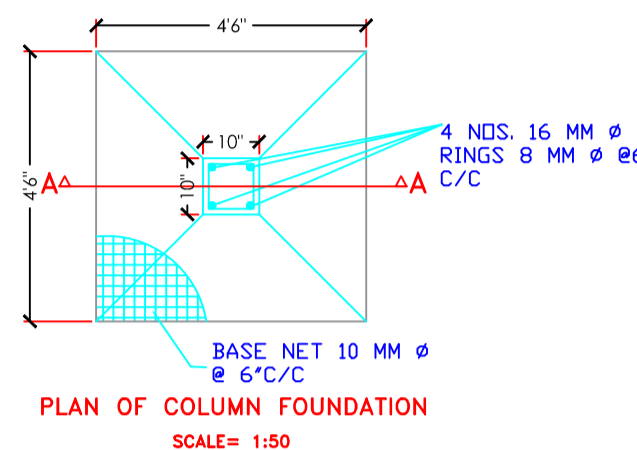

PLAN OF COLUMN FOUNDATION SCALE= 1:50

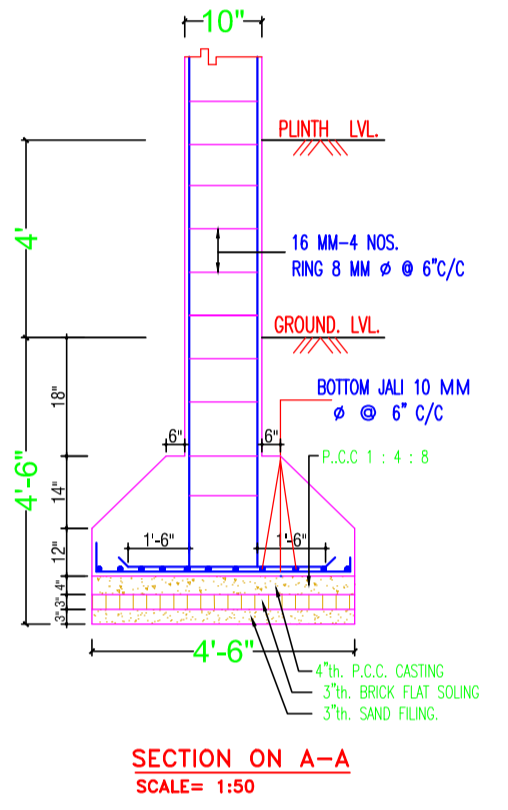

SECTION ON A-A SCALE= 1:50

Building :A (MD NASIM AKHTAR)

Floor Name	Gross Builtup Area	Deductions From Gross BUA/Area in Sq.mt.		Total Built Up Area (Sq.mt.)	Proposed FAR Area (Sq.mt.)		Total FAR Area (Sq.mt.)	Total Consumed Additional FAR Area (Sq.mt.)	Trmt (No.)
		Cutout	Resi.		Resi.	Resi.			
Ground Floor	62.88	0.91		61.97	61.97	61.97	61.97	61.97	01
Terrace Floor	0.00	0.00		0.00	0.00	0.00	0.00	0.00	00
Total:	62.88	0.91		61.97	61.97	61.97	61.97	61.97	01
Total Number of Same Buildings	1								
Total:	62.88	0.91		61.97	61.97	61.97	61.97	61.97	01

Building USE/SUBUSE Details

Building Name	Building Use	Building SubUse	Building Structure
A (MD NASIM AKHTAR)	Residential	Residential Bldg/Apartment	Non-Highrise

Proposal Basic Information

Proposal File No.	LNP/BP/0016/W04/2018
Owner Name	MD NASIM AKHTAR
Khata No	133
Plot No	740
Village Name	Lohardaga
Use	Residential
SubUse	Residential Bldg/Apartment

AREA STATEMENT		VERSION NO.:	1.0.28
LOHARDAGA NAGAR PARISHAD		VERSION DATE:	30/06/2018
PROJECT DETAIL:			
Region: JHARKHAND URBAN LOCAL BODIES	Plot Use: Residential		
District: LOHARDAGA	Plot Use: Residential Bldg/Apartment		
Authority: LOHARDAGA NAGAR PARISHAD	Plot/Nearby/Religious Structure: NA		
Inward No: LNP/BP/0016/W04/2018	Plot/SubPlot No: 740		
Application Type: General Proposal	North: -		
Project Type: Building Permission	South: -		
Nature of Development: New	East: -		
Location of Development Area: Old Area	West: -		
AREA DETAILS:			
AREA OF PLOT (Minimum)	(A)		SQ.MT. 121.36
Deduction for NetPlot Area			
Surrender Free of Cost			16.19
Total			16.19
NET AREA OF PLOT(Gross Plot Area - Deduction from Gross Plot area)	(A-Deductions)		105.16
Deduction for Balance Plot Area(from Gross Plot Area)			
Surrender Free of Cost			16.19
Total			13.27
Common Plot			29.46
BALANCE AREA OF PLOT(Net Plot Area - Recreational/Amenity space)	(A-Deductions)		91.90
PLOT AREA FOR COVERAGE(Net Plot Area)	(A-Deductions)		105.16
Plot Area for FAR (Net Plot Area + Road Widening Area)	(A-Deductions)		121.36
COVERAGE CHECK			
Permissible Coverage area (70.00 %)			73.61
Proposed Coverage Area (58.93 %)			61.97
Total Prop. Coverage Area (58.93 %)			61.97
Balance coverage area (11.07 %)			11.64
FAR CHECK			
Perm. FAR Area (1.50)			182.04
Total Perm. FAR area			182.04
Residential FAR			61.97
Proposed FAR Area			61.97
Total Proposed FAR Area			61.97
Consumed FAR (Factor)			0.51
Balance FAR Area			120.07
BUILT UP AREA CHECK			
Total Proposed BuiltUp Area			61.97
ARCHITECT (Regd) ASHWINI KUMAR SAHU			
ENGINEER (Regd)			
SUPERVISOR (Regd)			
OWNER (Regd) MD NASIM AKHTAR			
DEVELOPMENT AUTHORITY LOCAL BODY			

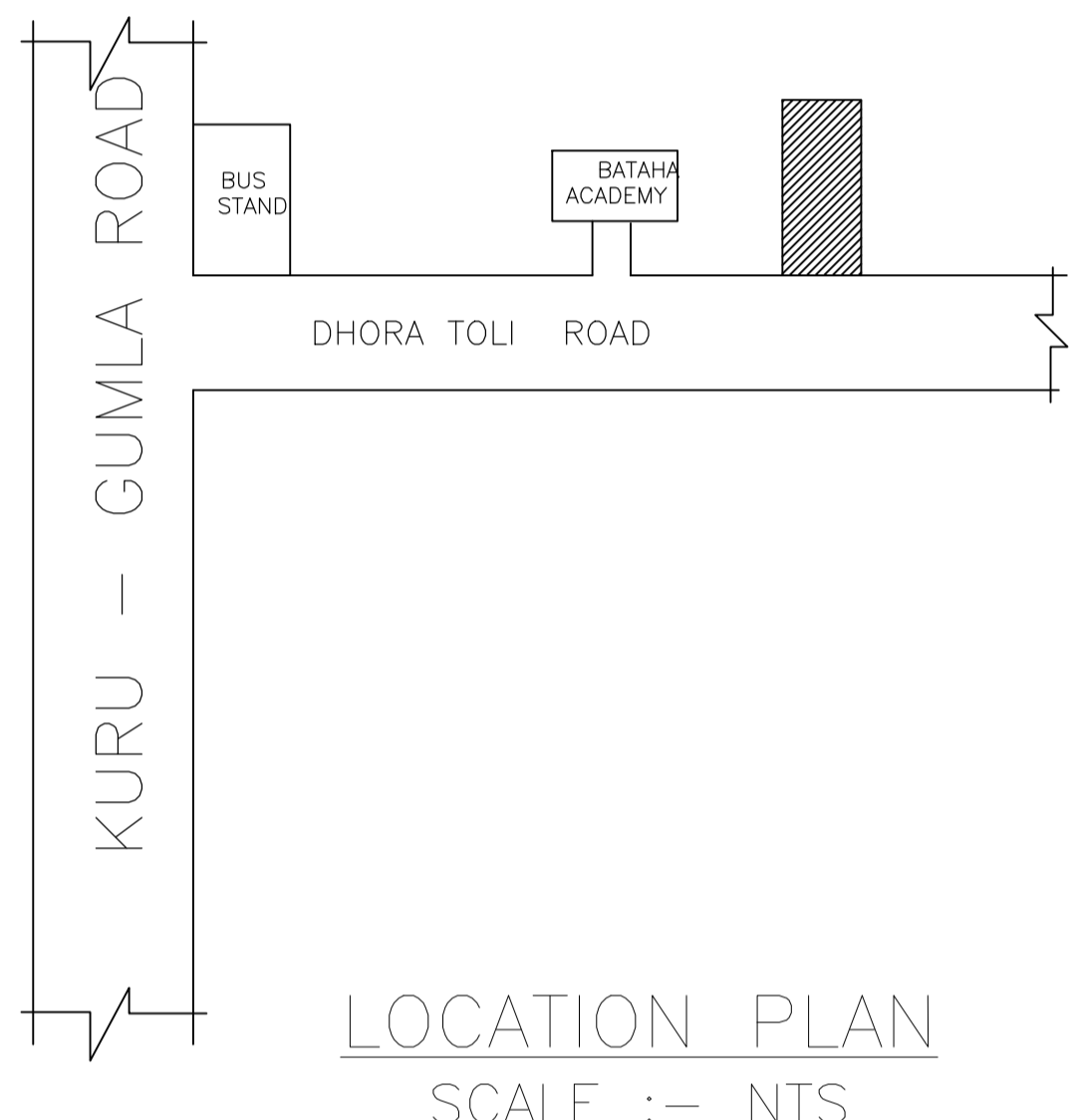

LOCATION PLAN SCALE :- NTS

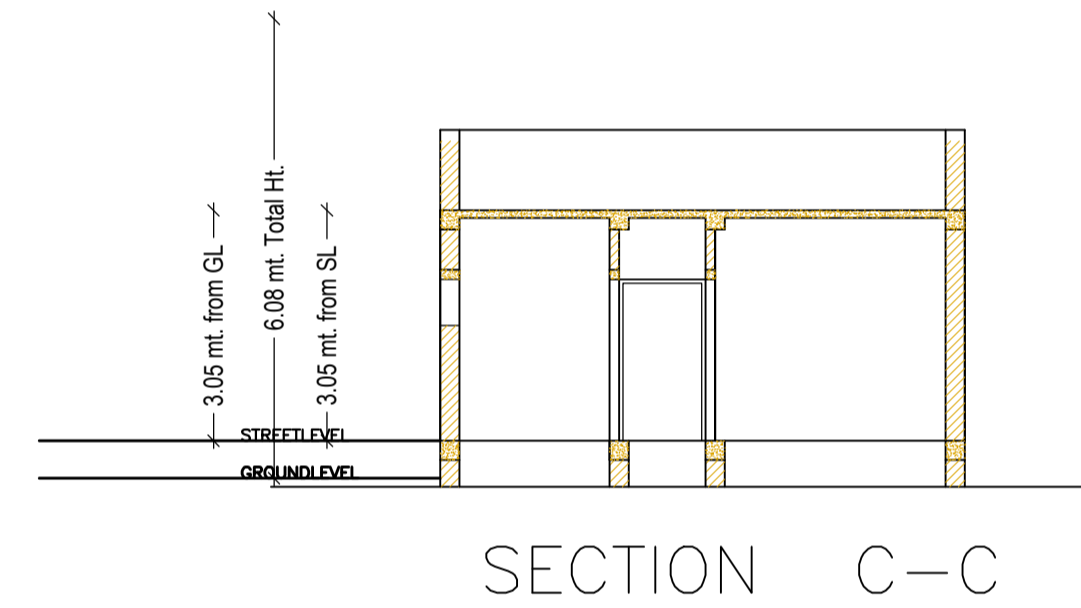

SECTION C-C

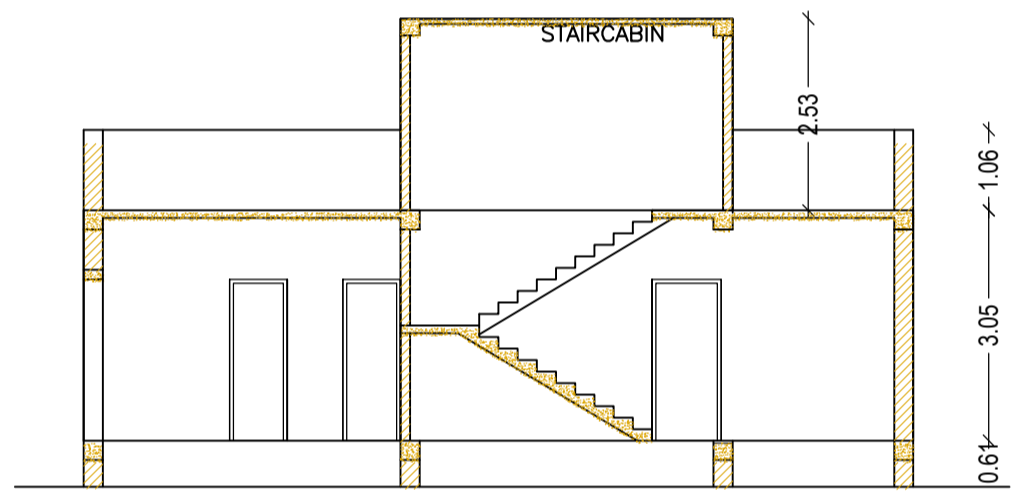

SECTION B-B

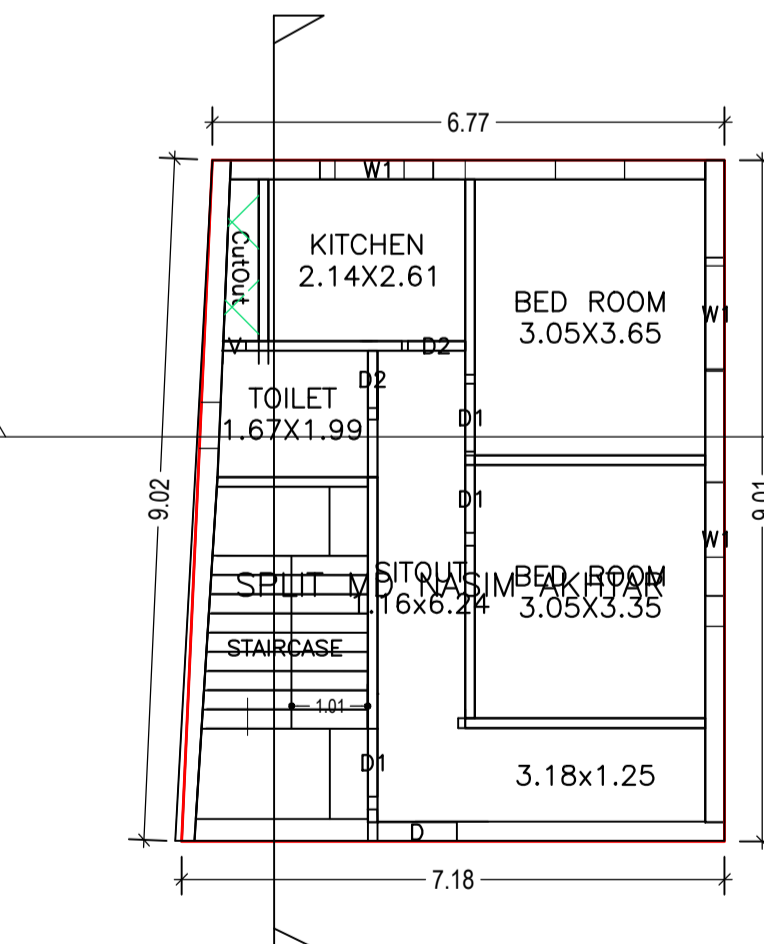

GROUND FLOOR PLAN (Proposed) (SCALE 1:100)

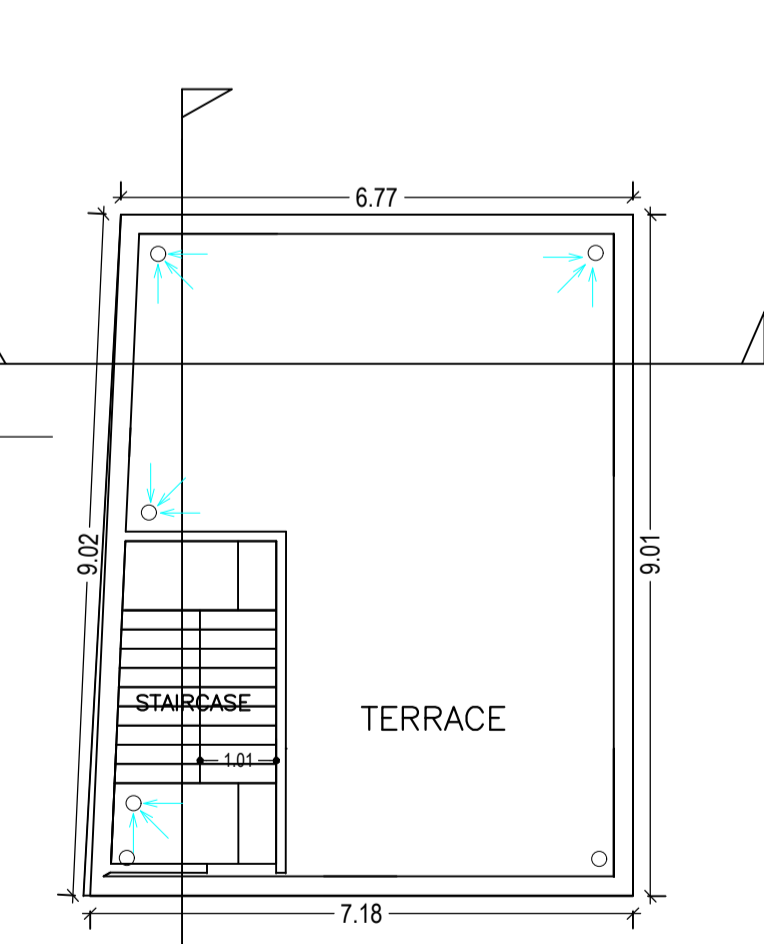

TERRACE FLOOR PLAN (SCALE 1:100)

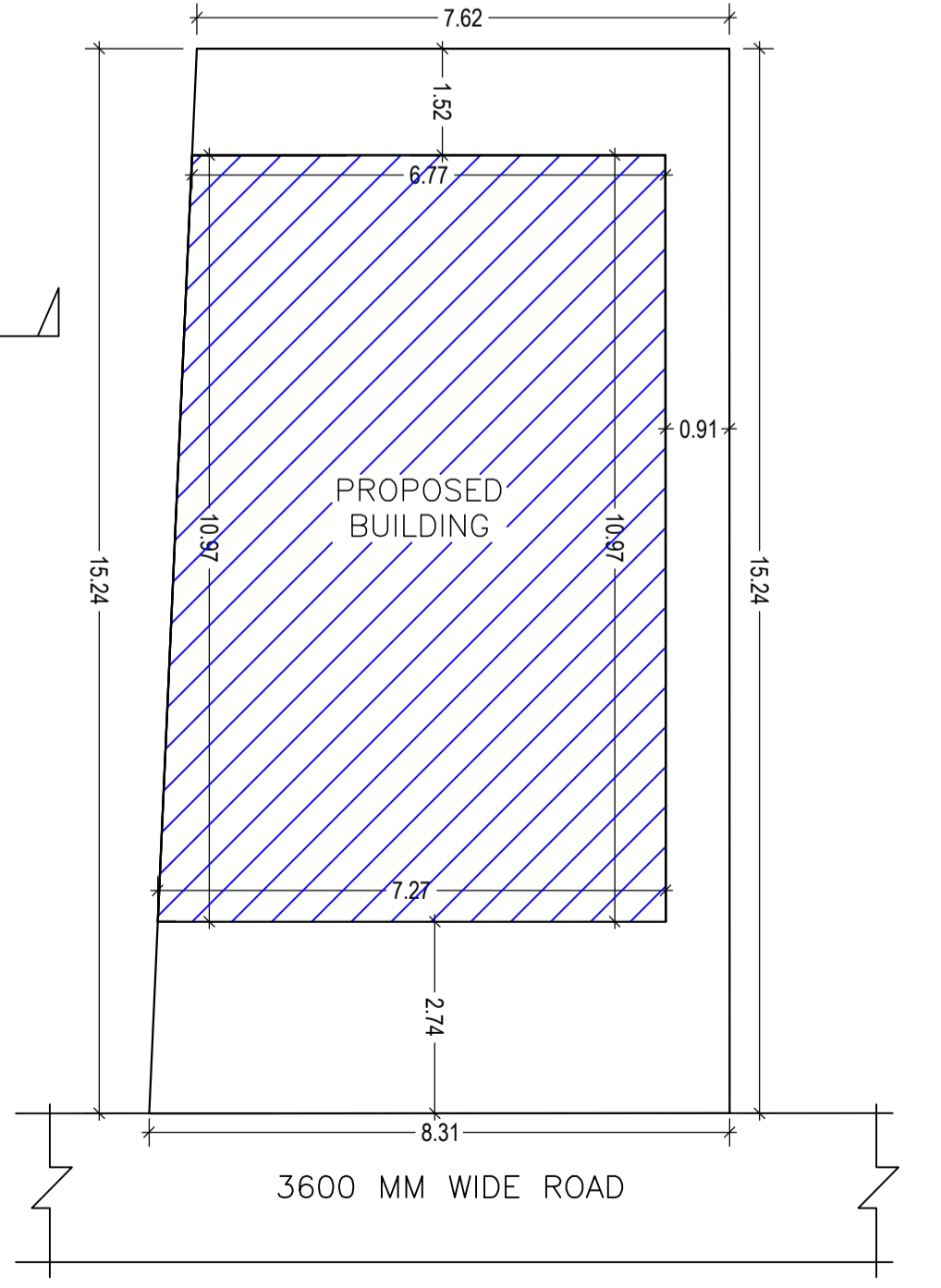

SITE PLAN SCALE :- 1:100

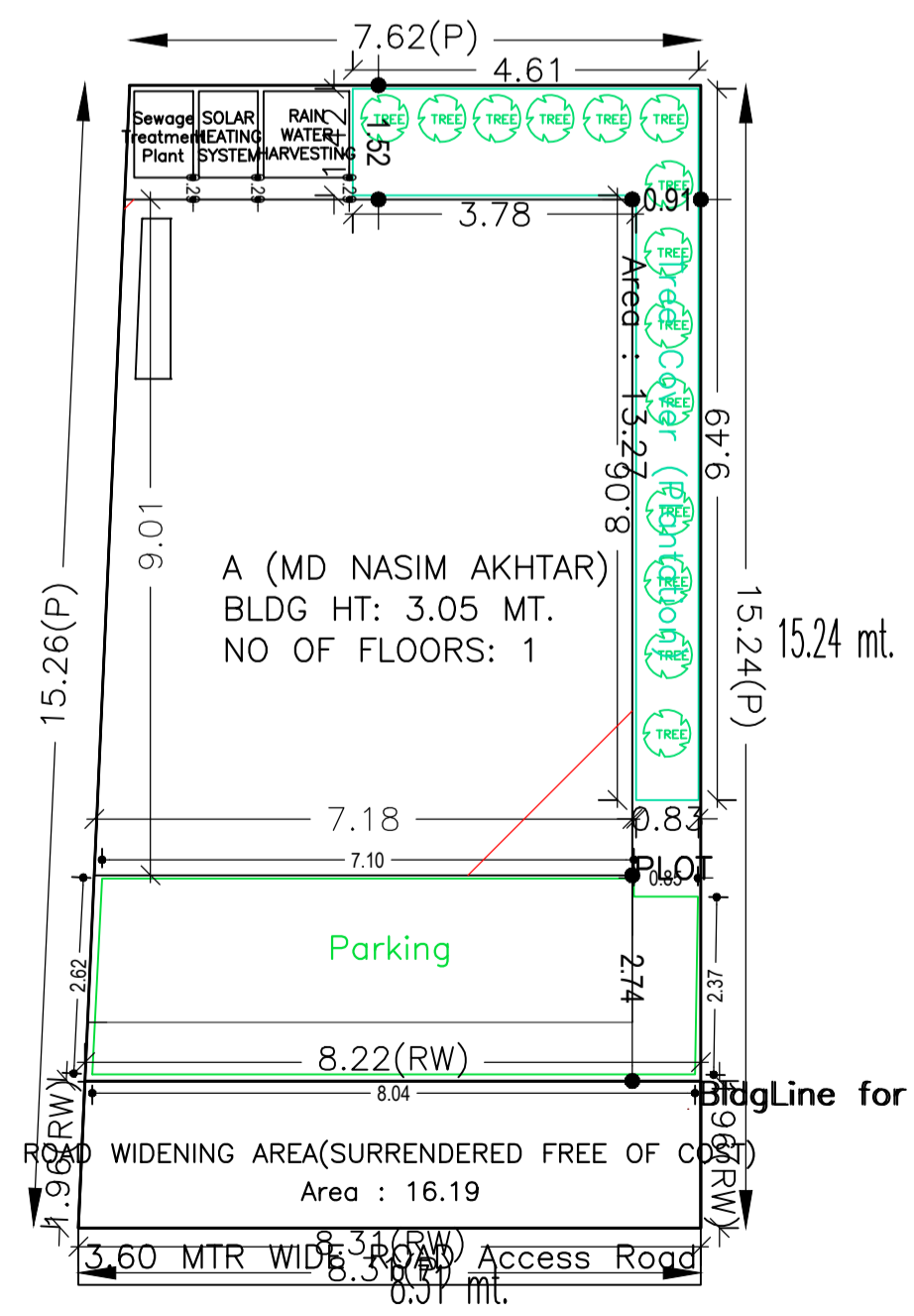

SITE PLAN

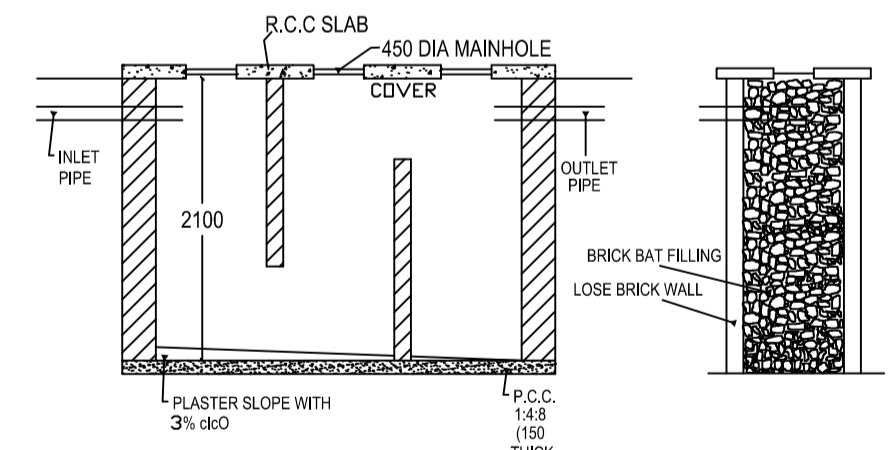

SECTION N.-N.

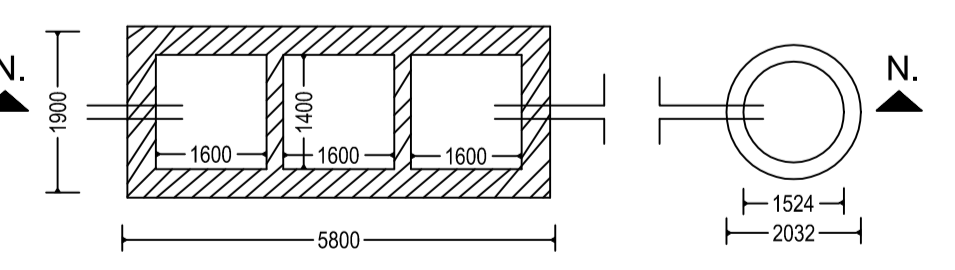

DETAIL OF SEPTIC TANK & SOAKPIT.

FAR & Tenement Details (Table 4c-1)

Building	No. of Same Bldg	Gross Built Up Area (Sq.mt.)	Deductions From Gross BUA/Area in Sq.mt. Cutout	Total Built Up Area (Sq.mt.)	Proposed FAR Area (Sq.mt.) Resi.	Total FAR Area (Sq.mt.)	Total Consumed Additional FAR Area (Sq.mt.)	Trmt (No.)
A (MD NASIM AKHTAR)	1	62.88	0.91	61.97	61.97	61.97	61.97	01
Grand Total :	1	62.88	0.91	61.97	61.97	61.97	61.97	01

SCHEDULE OF DOOR:

BUILDING NAME	NAME	LENGTH	HEIGHT	NOS
A (MD NASIM AKHTAR)	D2	0.76	2.13	02
A (MD NASIM AKHTAR)	D1	0.90	2.13	03
A (MD NASIM AKHTAR)	D	1.05	2.13	01

SCHEDULE OF WINDOW/VENTILATION:

BUILDING NAME	NAME	LENGTH	HEIGHT	NOS
A (MD NASIM AKHTAR)	V	0.31	1.00	01
A (MD NASIM AKHTAR)	W1	1.50	2.50	03

Buildingwise Floor FAR Details

Floor Name	Building Name A (MD NASIM AKHTAR)		Total	
	Proposed Built Up Area (Sq.mt.)	Proposed FAR Area (Sq.mt.)	Total Proposed Built Up Area (Sq.mt.)	Total FAR Area (Sq.mt.)
Ground Floor	61.97	61.97	61.97	61.97
Terrace Floor	0.00	0.00	0.00	0.00
Total:	61.97	61.97	61.97	61.97

LTP NAME AND SIGNATURE	STRUCTURAL ENG'S NAME AND SIGNATURE	BUILDER NAME AND SIGNATURE
ASHWINI KUMAR SAHU LNP/ENG/0005/2017		