



FRONT ELEVATION
Scale - 1:100

RIGHT SIDE ELEVATION
Scale - 1:100

COLOR INDEX

PLOT BOUNDARY	Black
ABUTTING ROAD	Green
PROPOSED CONSTRUCTION	Red
COMMON PLOT	Yellow
ROAD WIDENING AREA	Blue
EXISTING (To be retained)	Orange
EXISTING (To be demolished)	Light Blue

FAR & Tenement Details (Table 4c-1)

Building	No. of Same Bldg	Total Built Up Area (Sq.mt.)	Proposed FAR Area (Sq.mt.) Resi.	Total FAR Area (Sq.mt.)	Total Consumed Additional FAR Area (Sq.mt.)	Tnmt (No.)
A (SMT DEEPA CHAUDHARY)	1	149.20	149.20	149.20	149.20	01
Grand Total :	1	149.20	149.20	149.20	149.20	01

Buildingwise Floor FAR Details

Floor Name	Building Name A (SMT DEEPA CHAUDHARY)		Total	
	Proposed Built Up Area (Sq.mt.)	Proposed FAR Area (Sq.mt.)	Total Proposed Built Up Area (Sq.mt.)	Total FAR Area (Sq.mt.)
Ground Floor	74.60	74.60	74.60	74.60
First Floor	74.60	74.60	74.60	74.60
Terrace Floor	0.00	0.00	0.00	0.00
	149.20	149.20	149.20	149.20

Proposal Basic Information

Proposal File No.	LNP/BI/0034/W16/2018
Owner Name	DEEPA CHAUDHARY
Khata No	398/399
Plot No	490/2360, 490/2361, 490/2366
Village Name	Lohardaga
Use	Residential
SubUse	Bungalow/ Dwelling / Non Apartment

UnitBUA Table for Building :A (SMT DEEPA CHAUDHARY)

FLOOR	Name	UnitBUA Type	UnitBUA Area	Carpet Area	No. of Rooms	No. of Tenement
GROUND FLOOR PLAN	SPLIT A	FLAT	95.30	95.18	5	1
FIRST FLOOR PLAN	SPLIT A	FLAT	0.00	0.00	6	0
Total:	-	-	95.30	95.18	11	1

Building USE/SUBUSE Details

Building Name	Building Use	Building SubUse	Building Structure
A (SMT DEEPA CHAUDHARY)	Residential	Residential Bldg/Apartment	Non-Highrise

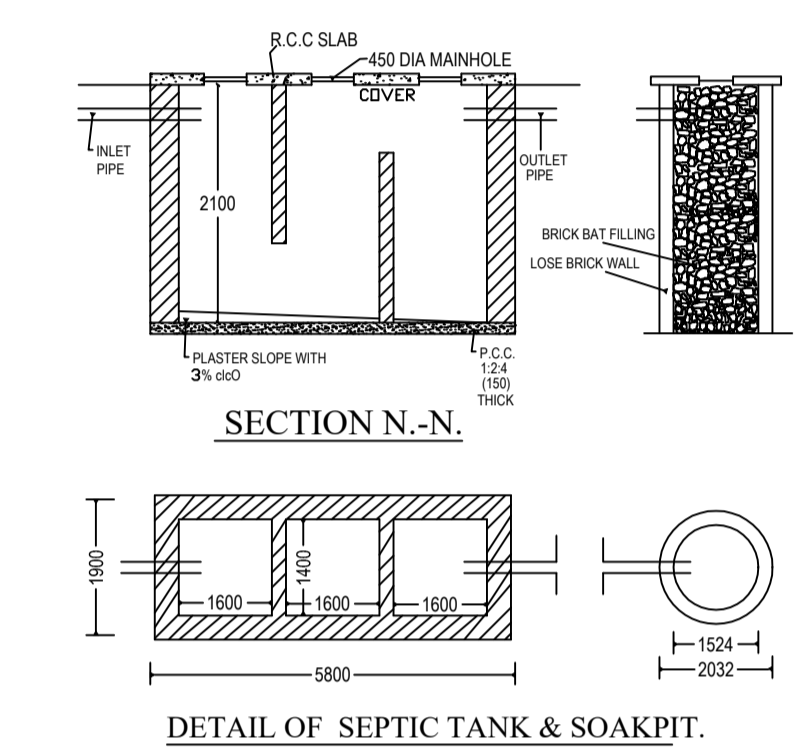

SECTION N.-N.

DETAIL OF SEPTIC TANK & SOAKPIT.

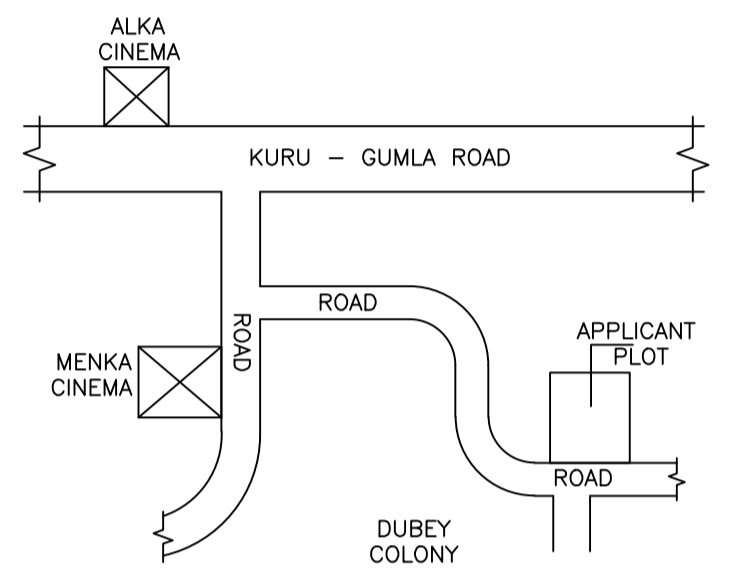

LOCATION PLAN
Scale - N.T.S.

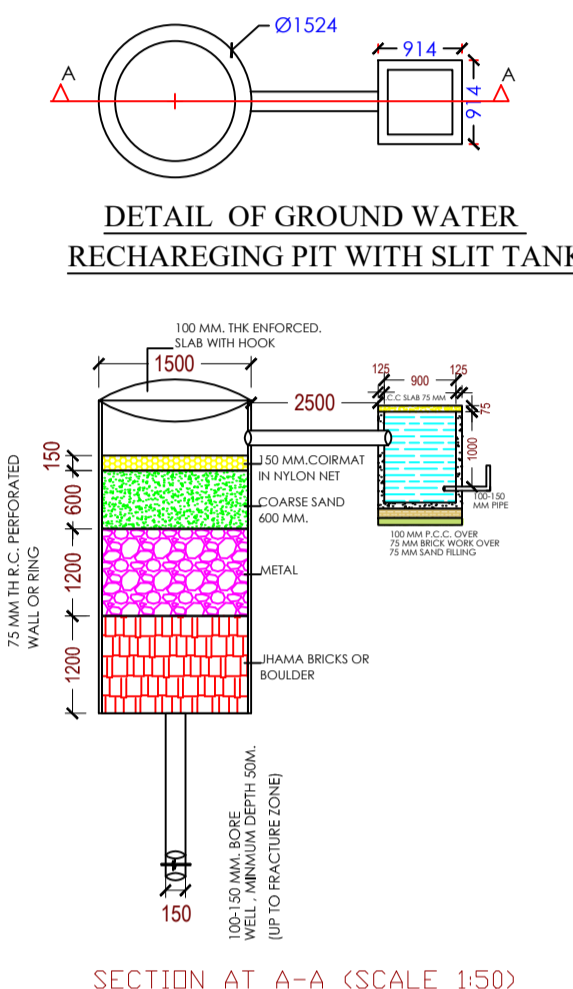

DETAIL OF GROUND WATER RECHARGING PIT WITH SLIT TANK

SECTION AT A-A (SCALE 1:50)

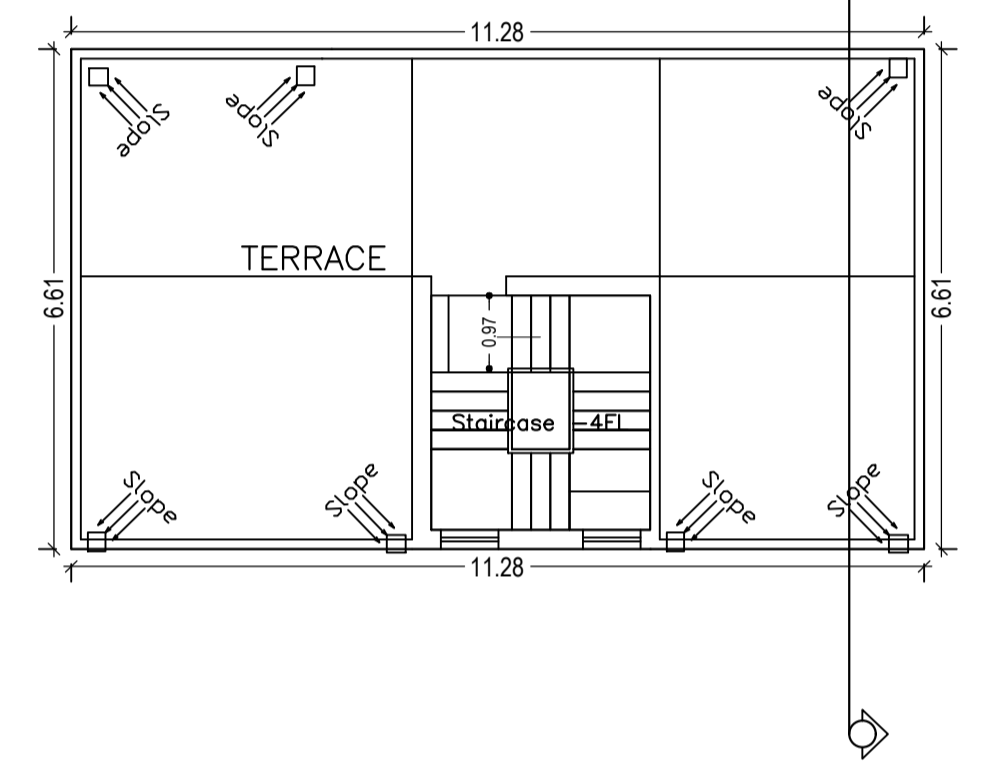

TERRACE FLOOR PLAN
(SCALE 1:100)

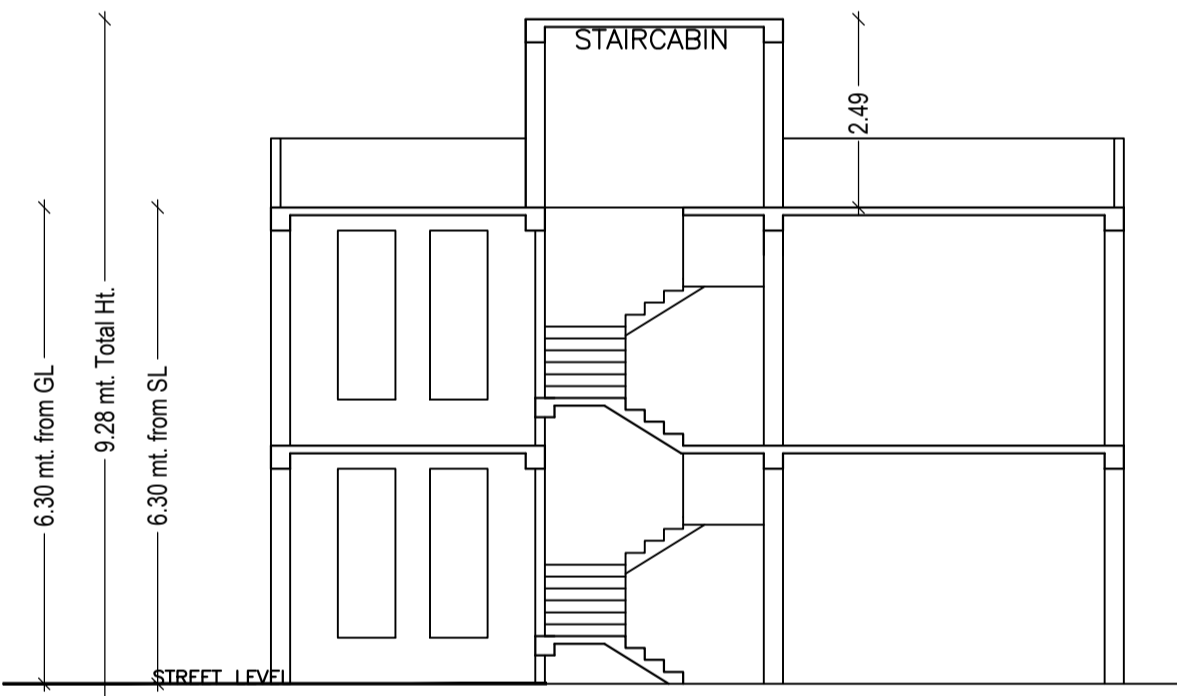

SECTION B-B
Scale - 1:100

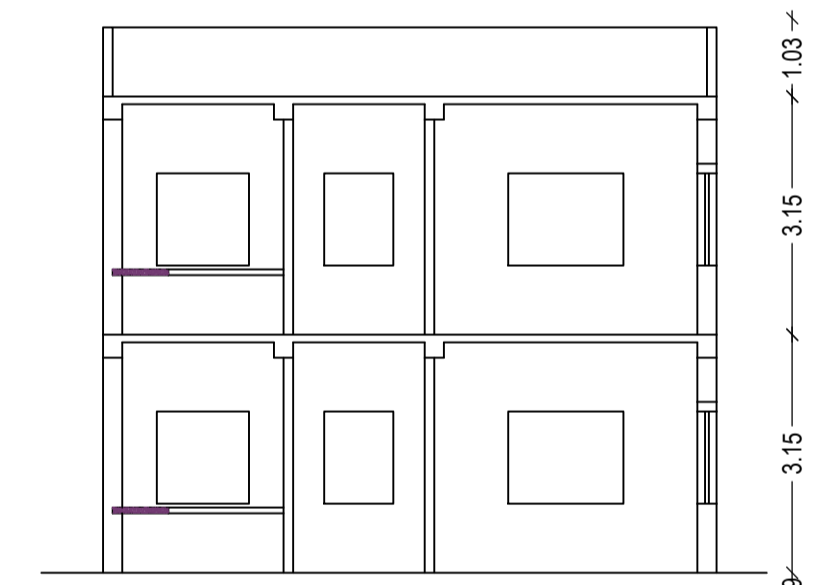

SECTION A-A
Scale - 1:100

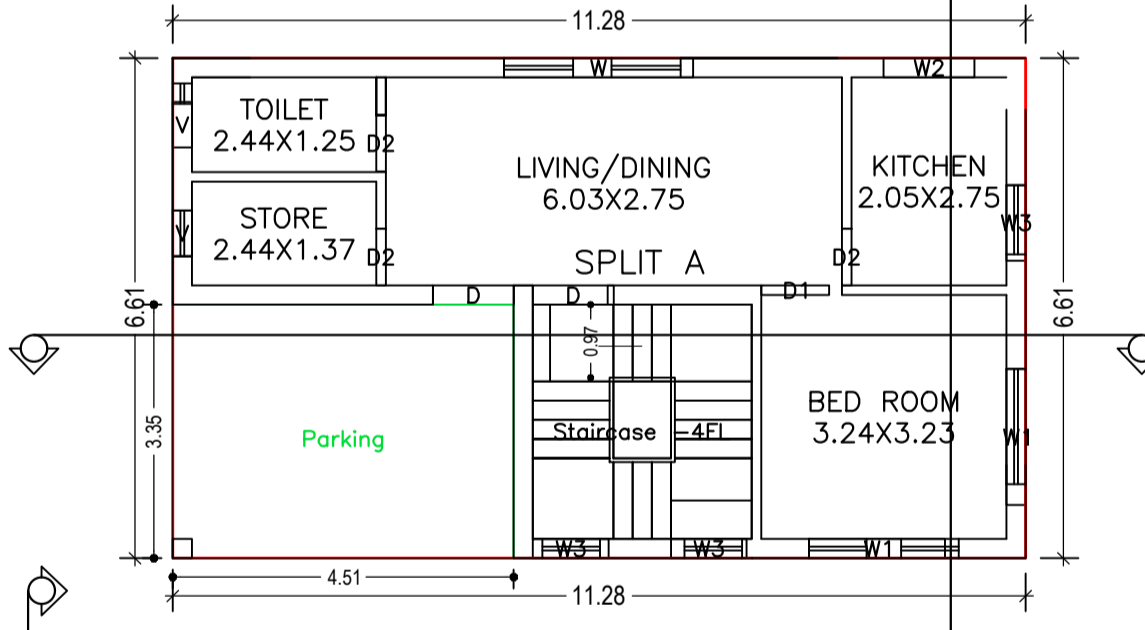

GROUND FLOOR PLAN
(Proposed)
(SCALE 1:100)

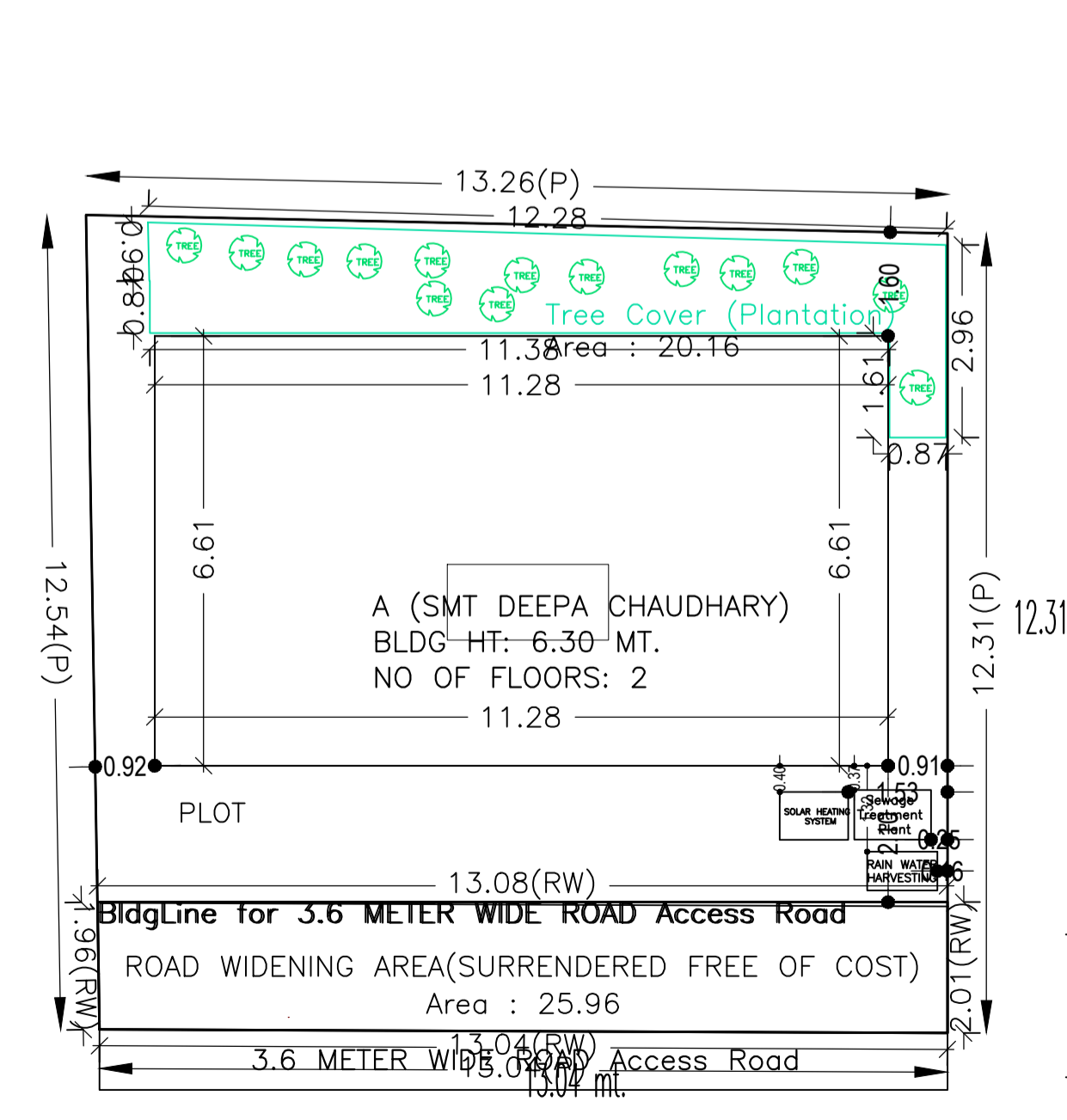

SITE PLAN
Scale - 1:100

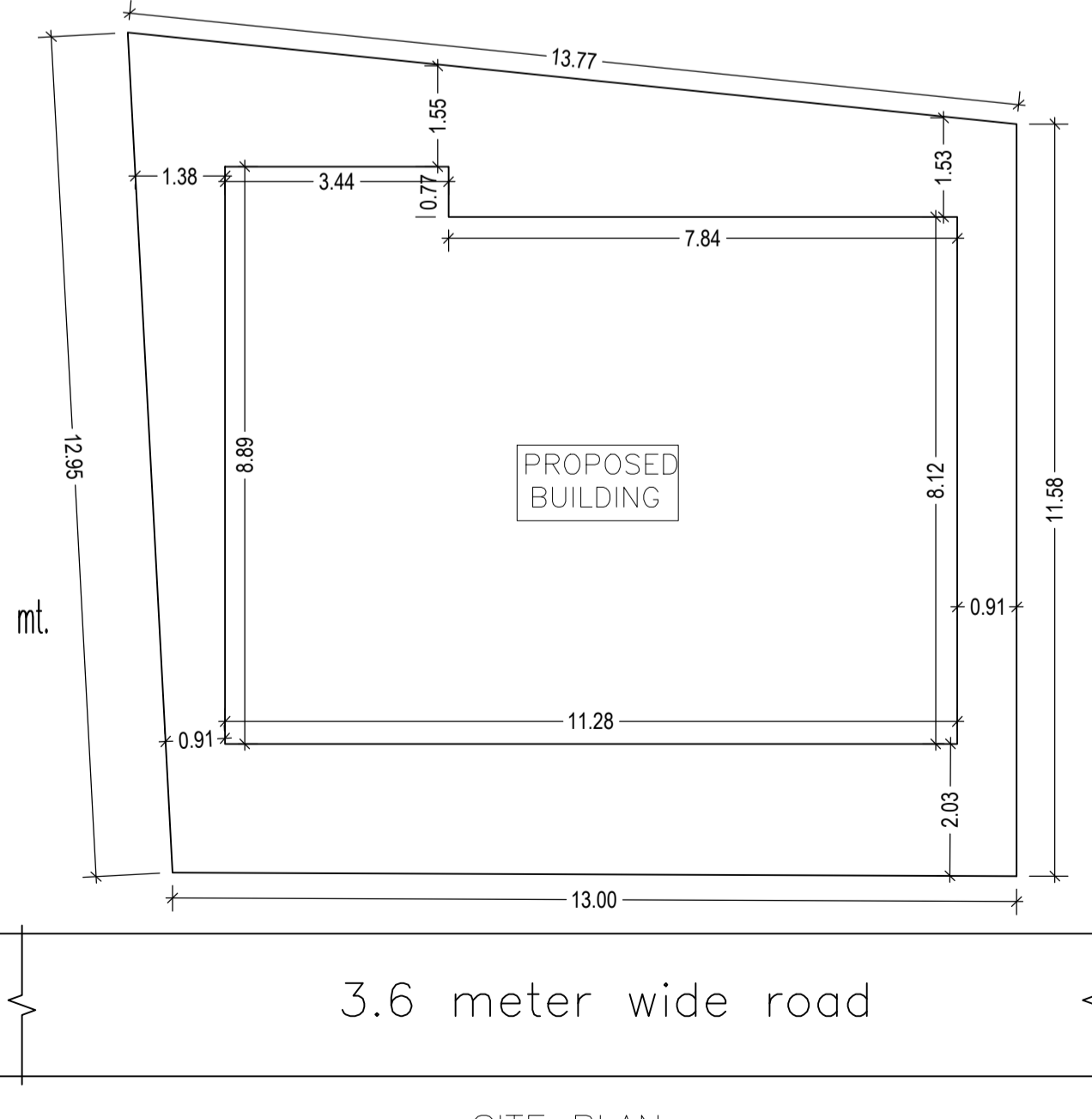

SITE PLAN
Scale - 1:100

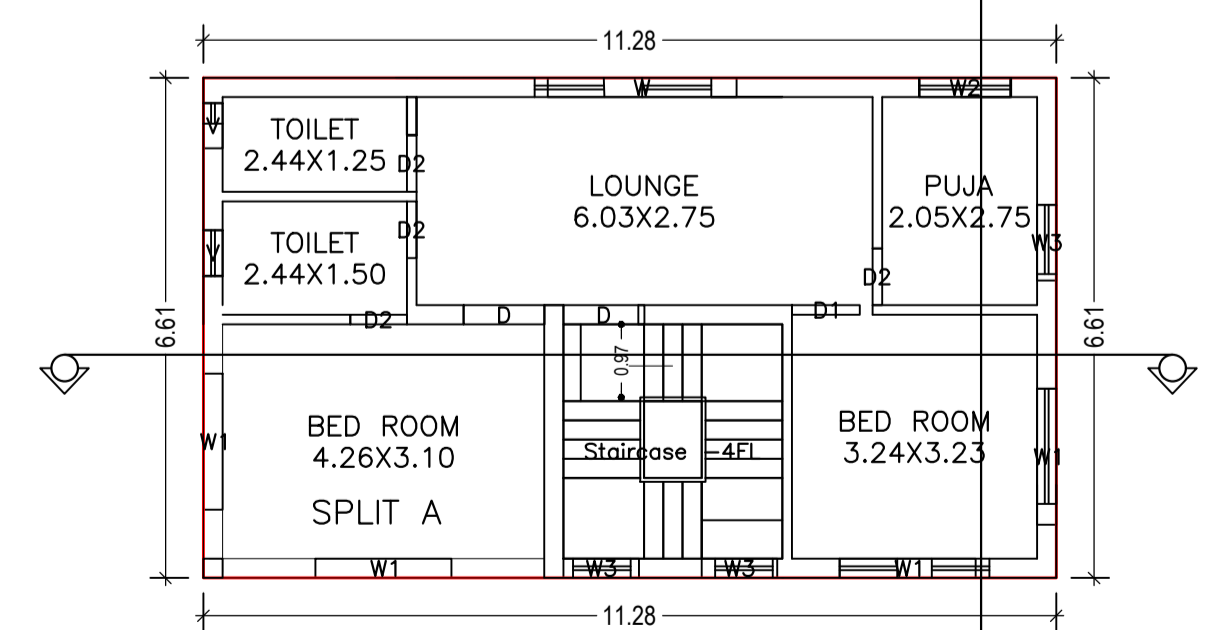

FIRST FLOOR PLAN
(Proposed)
(SCALE 1:100)

AREA STATEMENT
LOHARDAGA NAGAR
PARISHAD

VERSION NO.: 1.0.31
VERSION DATE: 30/06/2018

PROJECT DETAIL:
Region: JHARKHAND URBAN LOCAL BODIES
District: LOHARDAGA
Authority: LOHARDAGA NAGAR PARISHAD
Inward No: LNP/BI/0034/W16/2018
Application Type: General Proposal
Project Type: Building Permission
Nature of Development: New
Location of Development Area: New Area
Area Details:
Area of Plot (Minimum) (A)
Deduction for NetPlot Area
Surrender Free of Cost
Total
NET AREA OF PLOT(Gross Plot Area - Deduction from Gross Plot area)
Deduction for Balance Plot Area(from Gross Plot Area)
Surrender Free of Cost
Common Plot
Total
BALANCE AREA OF PLOT(Net Plot Area - Recreational/Amenity space)
PLOT AREA FOR COVERAGE(Net Plot Area)
Plot Area for FAR (Net Plot Area + Road/Widening Area)
COVERAGE CHECK
Permissible Coverage area (70.00 %)
Proposed Coverage Area (54.32 %)
Total Prop. Coverage Area (54.32 %)
Balance coverage area (15.68 %)
FAR CHECK
Perm. FAR Area (1.50)
Total Perm. FAR area
Residential FAR
Proposed FAR Area
Total Proposed FAR Area
Consumed FAR (Factor)
Balance FAR Area
BUILT UP AREA CHECK
Total Proposed BuiltUp Area
ARCHITECT (Regd)
ENGINEER (Regd)
SUPERVISOR (Regd)
OWNER (Regd)
DEVELOPMENT AUTHORITY
LOCAL BODY

SCHEDULE OF DOOR:

BUILDING NAME	NAME	LENGTH	HEIGHT	NOS
A (SMT DEEPA CHAUDHARY)	D2	0.75	2.13	07
A (SMT DEEPA CHAUDHARY)	D1	0.90	2.13	02
A (SMT DEEPA CHAUDHARY)	D	1.07	2.13	04

SCHEDULE OF WINDOW/VENTILATION:

BUILDING NAME	NAME	LENGTH	HEIGHT	NOS
A (SMT DEEPA CHAUDHARY)	V	0.60	1.20	04
A (SMT DEEPA CHAUDHARY)	W3	1.00	2.70	06
A (SMT DEEPA CHAUDHARY)	W2	1.20	2.70	02
A (SMT DEEPA CHAUDHARY)	W1	1.80	2.70	06
A (SMT DEEPA CHAUDHARY)	W	2.50	2.70	02

Building :A (SMT DEEPA CHAUDHARY)

Floor Name	Total Built Up Area (Sq.mt.)	Proposed FAR Area (Sq.mt.) Resi.	Total FAR Area (Sq.mt.)	Total Consumed Additional FAR Area (Sq.mt.)	Tnmt (No.)
Ground Floor	74.60	74.60	74.60	74.60	01
First Floor	74.60	74.60	74.60	74.60	00
Terrace Floor	0.00	0.00	0.00	0.00	00
Total :	149.20	149.20	149.20	149.20	01
Total Number of Same Buildings :	1				
Total :	149.20	149.20	149.20	149.20	01

LTP NAME AND SIGNATURE	STRUCTURAL ENG'S NAME AND SIGNATURE	BUILDER NAME AND SIGNATURE	DIGITAL SIGNATURE
ASHWINI KUMAR SAHU LNP/ENG/0005/2017			