

Required Parking(Table 7a)

Building Name	Type	SubUse	Area (Sq.mt.)	Units	Reqd./Unit	Prop.	Reqd./Unit	Car	Reqd./Unit	Prop.	Reqd./Unit	TwoWheeler	Reqd./Unit	Prop.
Total :								0	1			0	1	

Parking Check (Table 7b)

Vehicle Type	Reqd.		Prop.	
	No.	Area	No.	Area
Car	-	-	1	12.50
Total Car	1	12.50	1	12.50
TwoWheeler	-	-	1	2.00
Total TwoWheeler	1	2.00	1	2.00
Other Parking	-	-	-	31.11
Total	14.50	-	47.61	-

FAR & Tenement Details (Table 4c-1)

Building	No. of Same Bldg	Total Built Up Area (Sq.mt.)	Deductions (Area in Sq.mt.)	Proposed FAR Area (Sq.mt.)	Total FAR Area (Sq.mt.)	Total Consumed Additional FAR Area (Sq.mt.)	Tnmt (No.)
A (MANISH KUMAR SAHU SUBHAM SAHU RAJWARDHAN SAHU)	1	329.88	45.61	236.37	284.27	284.27	01
Grand Total :	1	329.88	45.61	236.37	284.27	284.27	01

Building :A (MANISH KUMAR SAHU SUBHAM SAHU RAJWARDHAN SAHU)

Floor Name	Total Built Up Area (Sq.mt.)	Deductions (Area in Sq.mt.)	Proposed FAR Area (Sq.mt.)		Total Consumed Additional FAR Area (Sq.mt.)	Tnmt (No.)
			Parking	Resi.		
Ground Floor	93.51	45.61	0.00	47.90	47.90	00
First Floor	116.21	0.00	116.21	116.21	116.21	01
Second Floor	120.16	0.00	120.16	120.16	120.16	00
Terrace Floor	0.00	0.00	0.00	0.00	0.00	00
Total :	329.88	45.61	236.37	284.27	284.27	01
Total Number of Same Buildings	1					
Total :	329.88	45.61	236.37	284.27	284.27	01

Buildingwise Floor FAR Details

Floor Name	Building Name		Total	
	A (MANISH KUMAR SAHU SUBHAM SAHU RAJWARDHAN SAHU)	Proposed FAR Area (Sq.mt.)	Total Proposed Built Up Area (Sq.mt.)	Total FAR Area (Sq.mt.)
Ground Floor	93.51		93.51	47.90
First Floor	116.21		116.21	116.21
Second Floor	120.16		120.16	120.16
Terrace Floor	0.00		0.00	0.00
Total :	329.88	284.27	329.88	

Proposal Basic Information

Proposal File No.	LNP/BP/0042/W13/2018
Owner Name	RAJWARDHAN SAHU MANISH KUMAR SAHU SUBHAM SAHU
Khata No	205
Plot No	1096
Village Name	Lohardaga
Use	Residential
SubUse	ResiComm Bldg

UnitBUA Table for Building :A (MANISH KUMAR SAHU SUBHAM SAHU RAJWARDHAN SAHU)

FLOOR	Name	UnitBUA Type	UnitBUA Area	Carpet Area	No. of Rooms	No. of Tenement
GROUND FLOOR PLAN	SHOP-2	SHOP	21.06	21.02	1	1
FIRST FLOOR PLAN	SPLIT A	FLAT	170.37	169.88	1	1
SECOND FLOOR PLAN	SPLIT A	FLAT	0.00	0.00	8	0
Total:	-	-	191.43	190.90	10	2

Building USE/SUBUSE Details

Building Use	Building Sub/Use	Building Structure
A (MANISH KUMAR SAHU SUBHAM SAHU RAJWARDHAN SAHU)	Residential	Residential Bldg/Apartment
		Non-Highrise

COLOR INDEX

PLOT BOUNDARY	[Red Line]
ABUTTING ROAD	[Green Line]
PROPOSED CONSTRUCTION	[Yellow Line]
COMMON PLOT	[Blue Line]
ROAD WIDENING AREA	[Orange Line]
EXISTING (To be retained)	[Black Line]
EXISTING (To be demolished)	[Red Line]

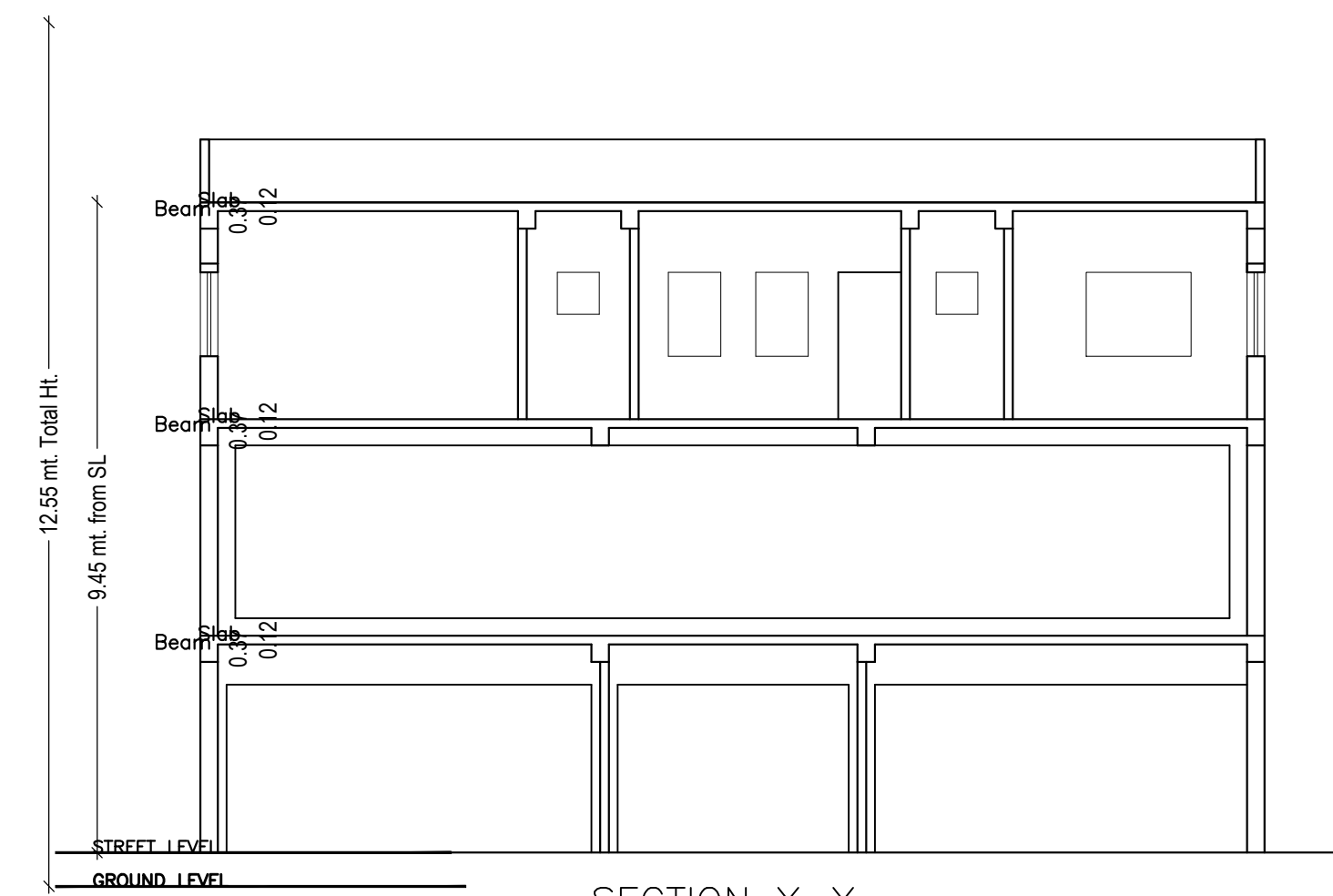

SECTION Y-Y
Scale - 1:100

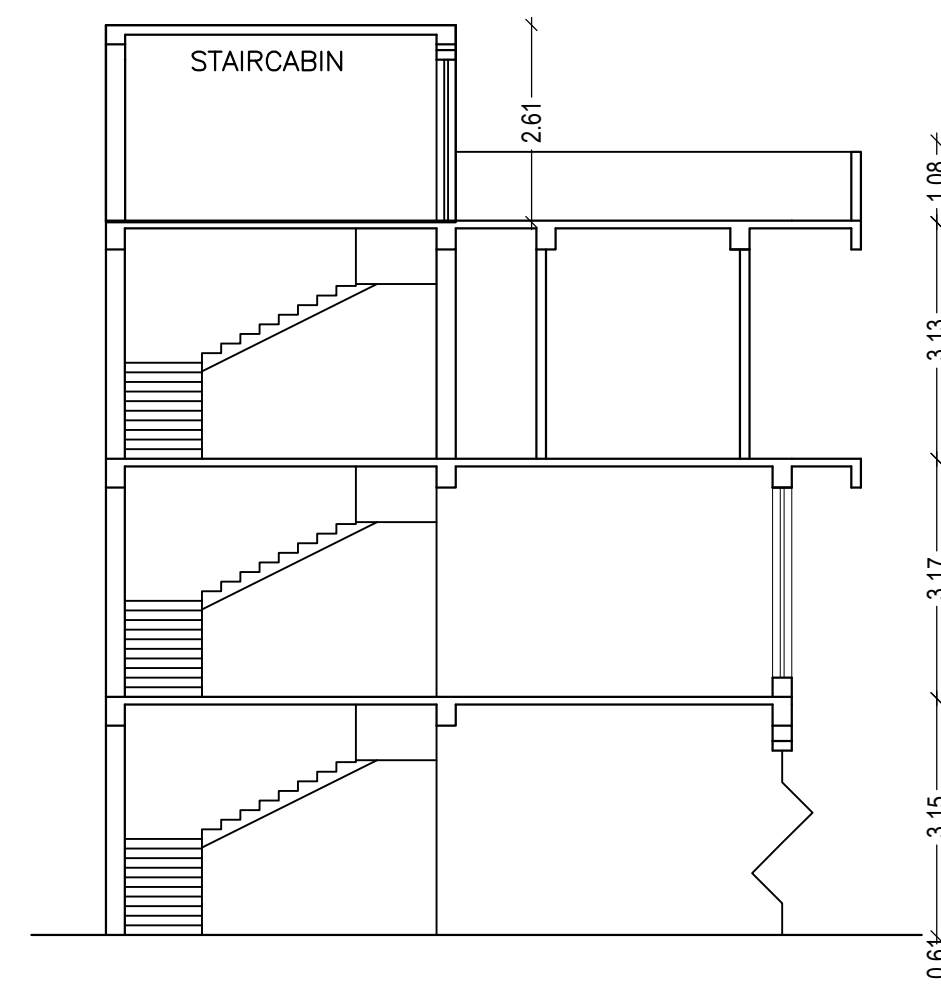

0.61

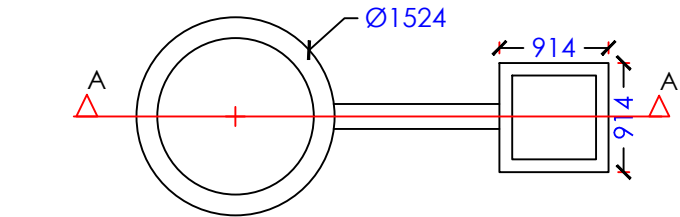

DETAIL OF GROUND WATER RECHARGING PIT WITH SLIT TANK

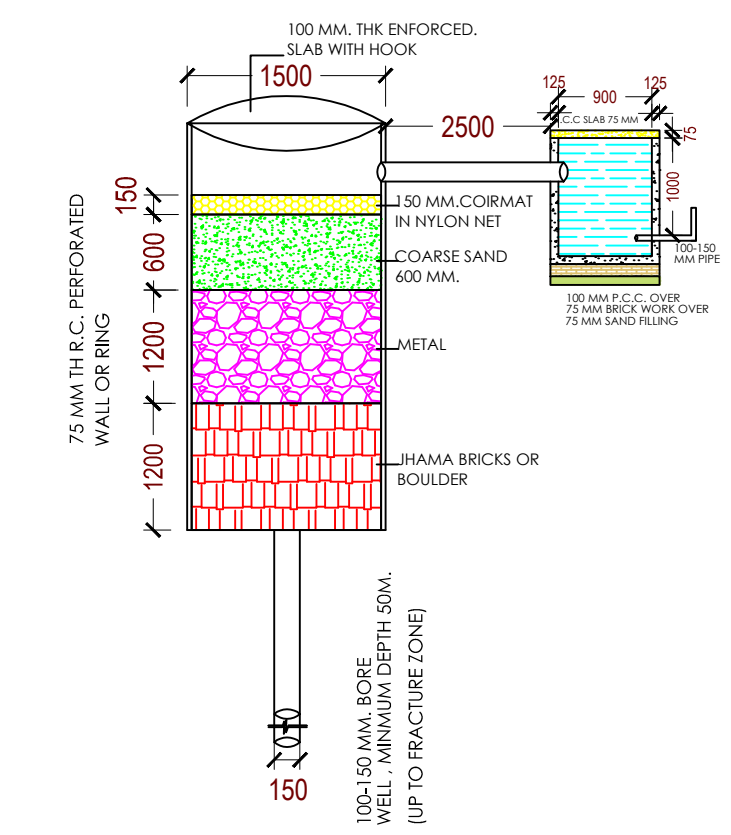

SECTION AT A-A (SCALE 1:50)

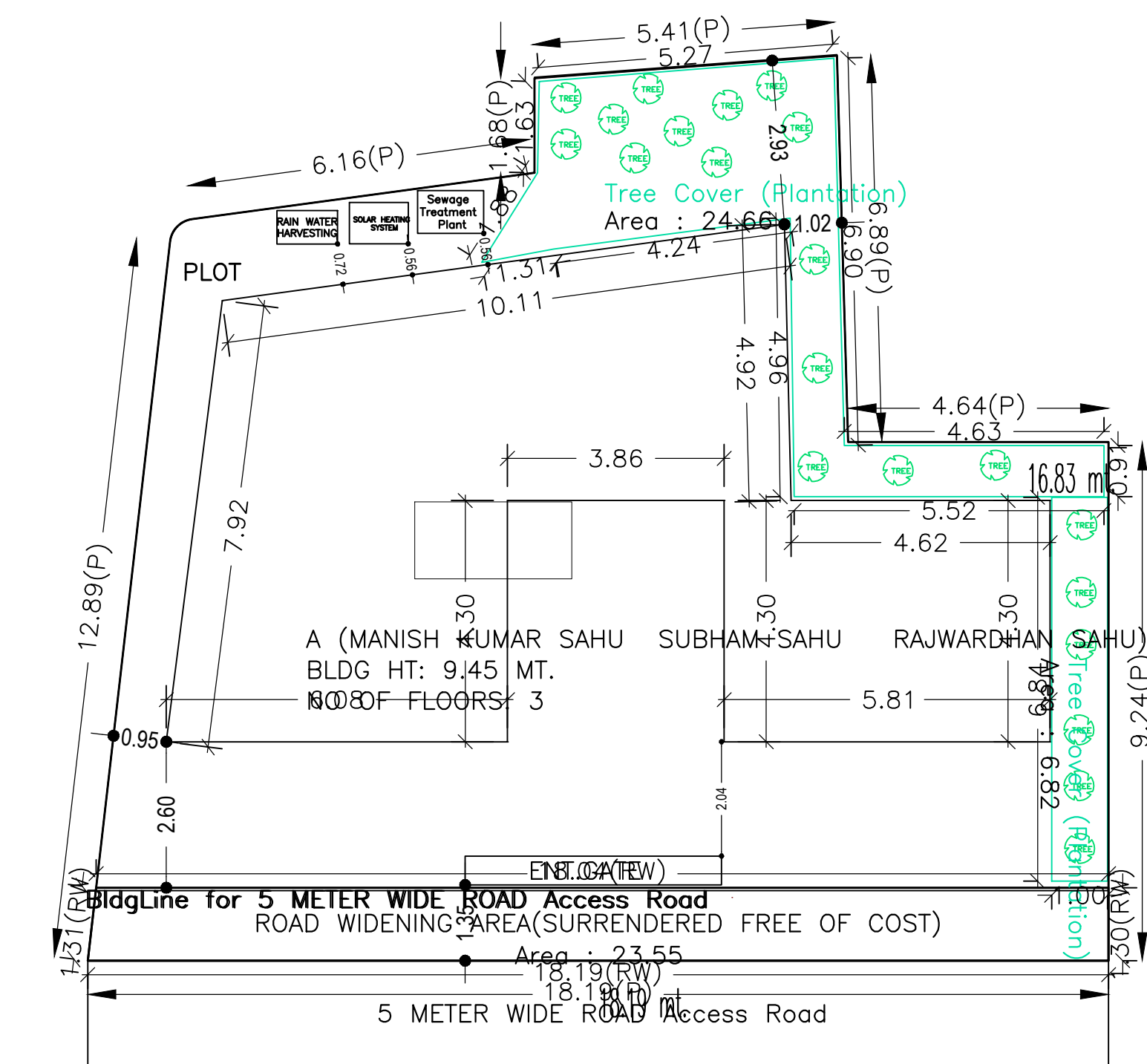

SITE PLAN

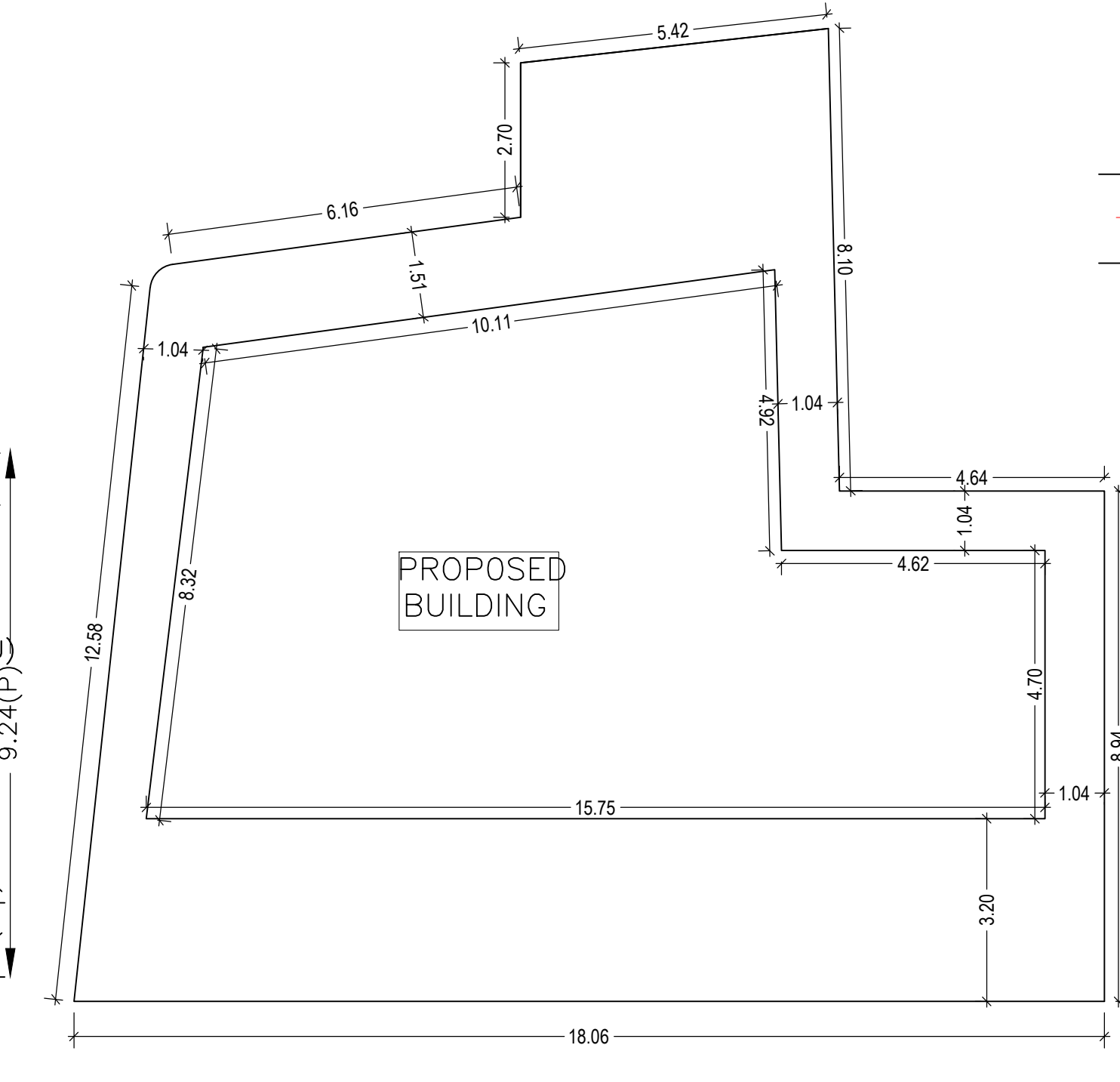

SITE PLAN
Scale - 1:100

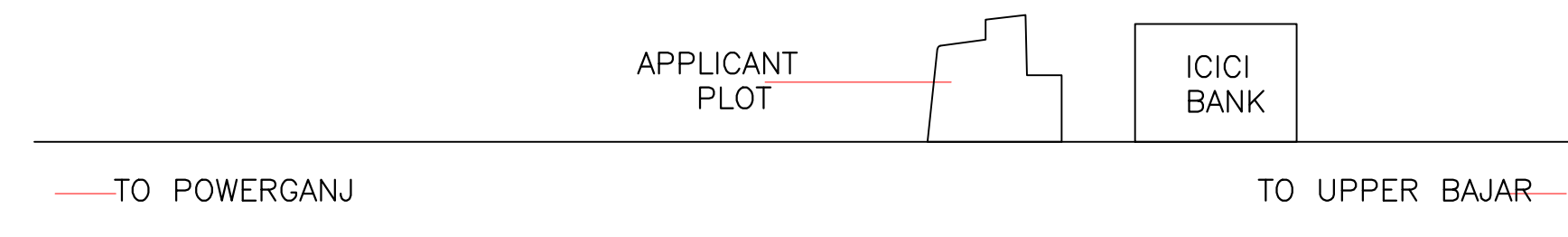

LOCATION PLAN
Scale - 1:100

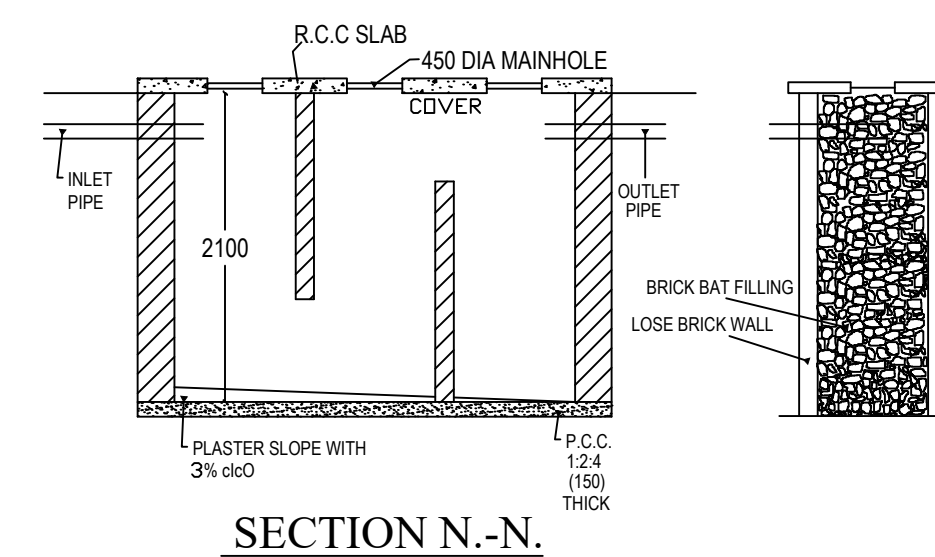

SECTION N-N.

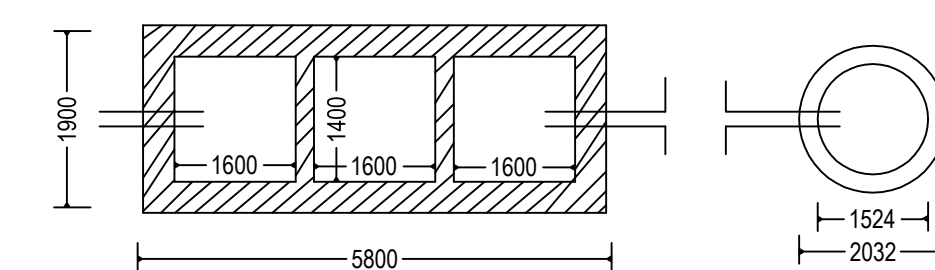

DETAIL OF SEPTIC TANK & SOAKPIT.

AREA STATEMENT	LOHARDAGA NAGAR PARISHAD	VERSION NO. : 1.0.32
PROJECT DETAIL:	Region: JHARKHAND URBAN LOCAL BODIES	Plot Use: Residential
	District: LOHARDAGA	Plot Sub/Use: ResiComm Bldg
	Authority: LOHARDAGA NAGAR PARISHAD	PlotNearby/ReligiousStructure: NA
	Inward_No: LNP/BP/0042/W13/2018	Plot/SubPlot No: 1096
	Application Type: General Proposal	North: Road Width - 3
	Project Type: Building Permission	South: Plot No. - 1097
	Nature of Development: New	East: Road Width - 3
	Location of Development Area: Old Area	West: Road Width - 5
AREA DETAILS:		SQ.MT.
AREA OF PLOT (Minimum)	(A)	228.90
Deduction for NetPlot Area		
Surrender Free of Cost		23.55
Total		23.55
NET AREA OF PLOT(Gross Plot Area - Deduction from Gross Plot area)	(A-Deductions)	205.35
Deduction for Balance Plot Area(from Gross Plot Area)		
Surrender Free of Cost		23.55
Common Plot		31.48
Total		55.03
BALANCE AREA OF PLOT(Net Plot Area - Recreational/Amenity space)	(A-Deductions)	173.88
PLOT AREA FOR COVERAGE(Net Plot Area)	(A-Deductions)	205.35
Plot Area for FAR (Net Plot Area + Road/Widening Area)	(A-Deductions)	228.90
COVERAGE CHECK		
Permissible Coverage area (70.00 %)		143.74
Proposed Coverage Area (45.54 %)		93.51
Total Prop. Coverage Area (45.54 %)		93.51
Balance coverage area (24.46 %)		50.23
FAR CHECK		
Perm. FAR Area (1.80)		412.02
Total Perm. FAR area		412.02
Residential FAR		236.38
Commercial FAR		47.90
Proposed FAR Area		284.28
Total Proposed FAR Area		284.28
Consumed FAR (Factor)		1.24
Balance FAR Area		127.74
BUILT UP AREA CHECK		
Total Proposed BuiltUp Area		329.88
ARCHITECT (Regd)		ASHWINI KUMAR SAHU
ENGINEER (Regd)		
SUPERVISOR (Regd)		
OWNER (Regd)		RAJWARDHAN SAHU MANISH KUMAR SAHU SUBHAM SAHU
DEVELOPMENT AUTHORITY		LOCAL BODY

SCHEDULE OF DOOR:

BUILDING NAME	NAME	LENGTH	HEIGHT	NOS
A (MANISH KUMAR SAHU SUBHAM SAHU RAJWARDHAN SAHU)	D2	0.75	2.13	04
A (MANISH KUMAR SAHU SUBHAM SAHU RAJWARDHAN SAHU)	D1	0.95	2.13	03
A (MANISH KUMAR SAHU SUBHAM SAHU RAJWARDHAN SAHU)	D	1.05	2.13	02
A (MANISH KUMAR SAHU SUBHAM SAHU RAJWARDHAN SAHU)	RS	3.50	2.13	01

SCHEDULE OF WINDOW/VENTILATION:

BUILDING NAME	NAME	LENGTH	HEIGHT	NOS
A (MANISH KUMAR SAHU SUBHAM SAHU RAJWARDHAN SAHU)	V	0.60	1.20	02
A (MANISH KUMAR SAHU SUBHAM SAHU RAJWARDHAN SAHU)	W3	1.00	2.70	03
A (MANISH KUMAR SAHU SUBHAM SAHU RAJWARDHAN SAHU)	W4	1.00	2.70	01
A (MANISH KUMAR SAHU SUBHAM SAHU RAJWARDHAN SAHU)	W2	1.80	2.70	04
A (MANISH KUMAR SAHU SUBHAM SAHU RAJWARDHAN SAHU)	W1	2.00	2.70	01
A (MANISH KUMAR SAHU SUBHAM SAHU RAJWARDHAN SAHU)	W	3.50	2.70	05

LTP NAME AND SIGNATURE	STRUCTURAL ENG'S NAME AND SIGNATURE	BUILDER NAME AND SIGNATURE	DIGITAL SIGNATURE
ASHWINI KUMAR SAHU LNP/ENG/0005/2017			

Proposal Basic Information	
Proposal File No.	LNP/BP/0042/W13/2018
Owner Name	RAJWARDHAN SAHU MANISH KUMAR SAHU SUBHAM SAHU
Khata No	205
Plot No	1096
Village Name	Lohardaga
Use	Residential
SubUse	ResiComm Bldg



FRONT ELEVATION
Scale - 1:100



RIGHT SIDE ELEVATION
Scale - 1:100

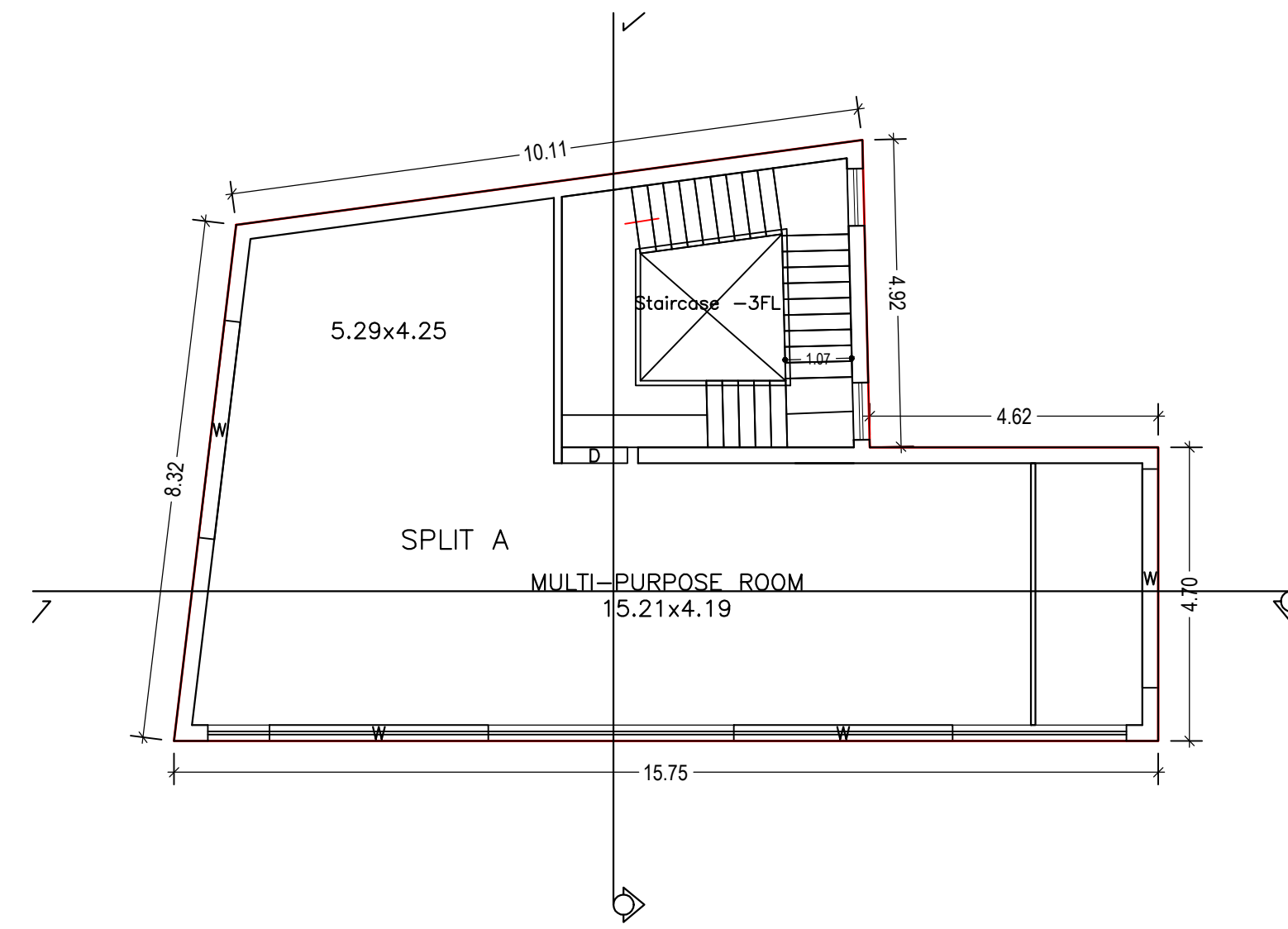

FIRST FLOOR PLAN
(Proposed)
(SCALE 1:100)

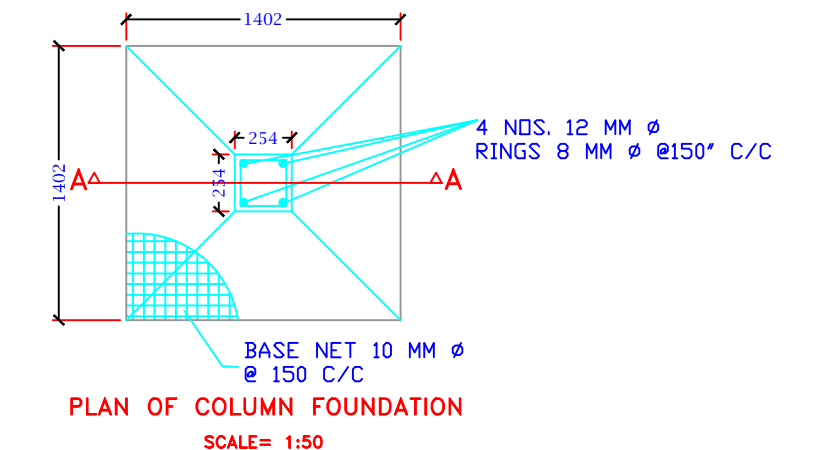

PLAN OF COLUMN FOUNDATION
SCALE= 1:50

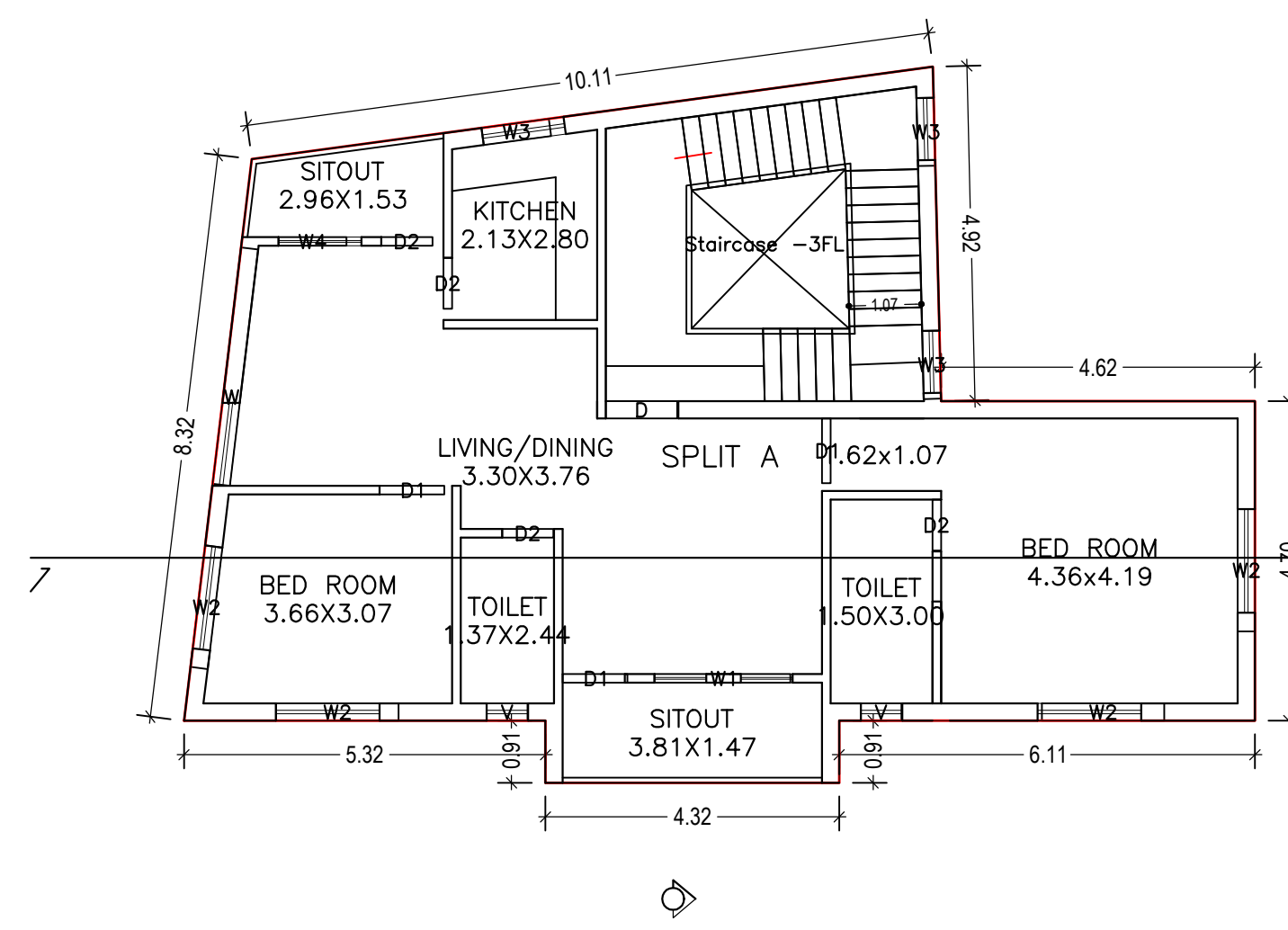

SECOND FLOOR PLAN
(Proposed)
(SCALE 1:100)

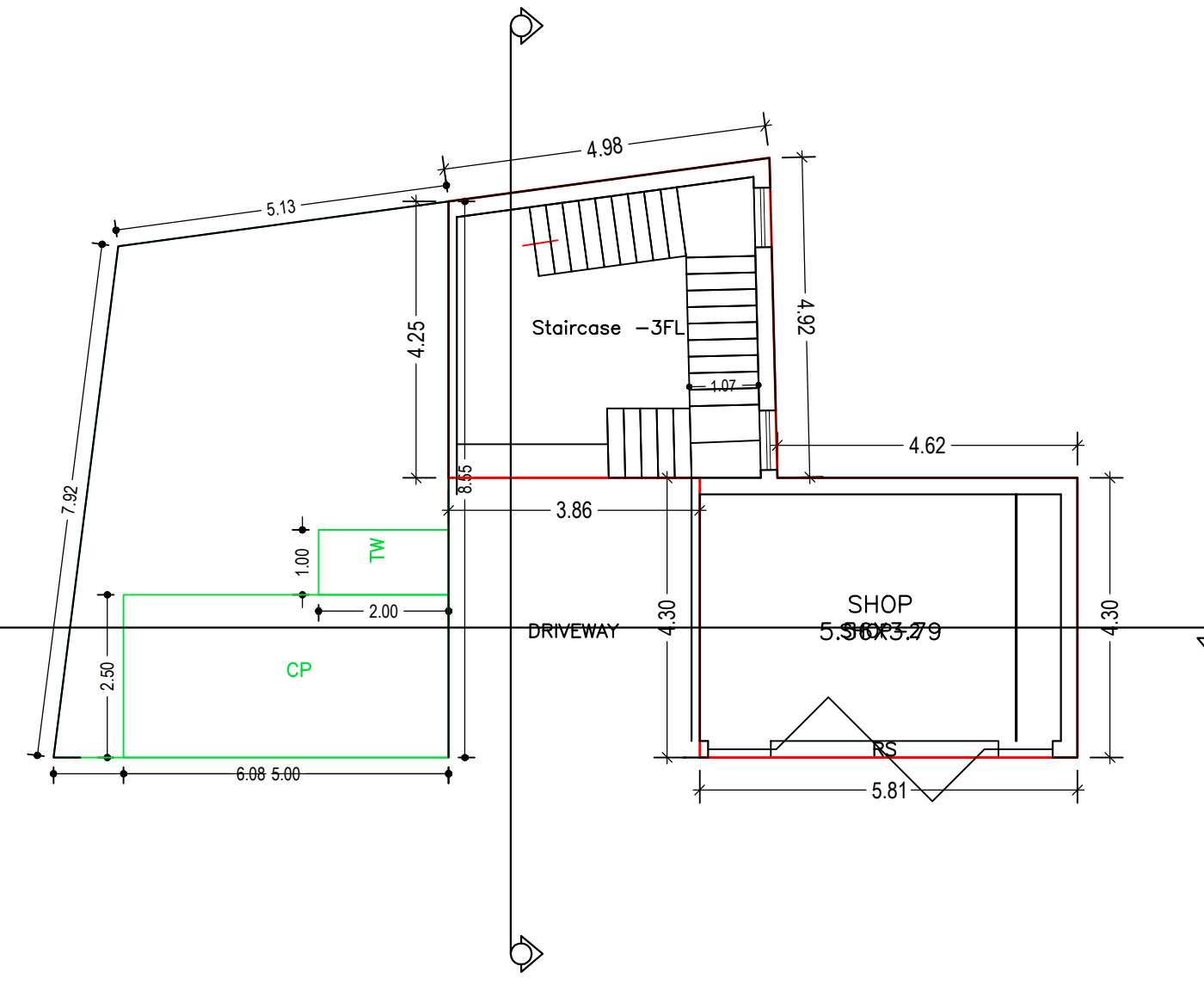

GROUND FLOOR PLAN
(Proposed)
(SCALE 1:100)

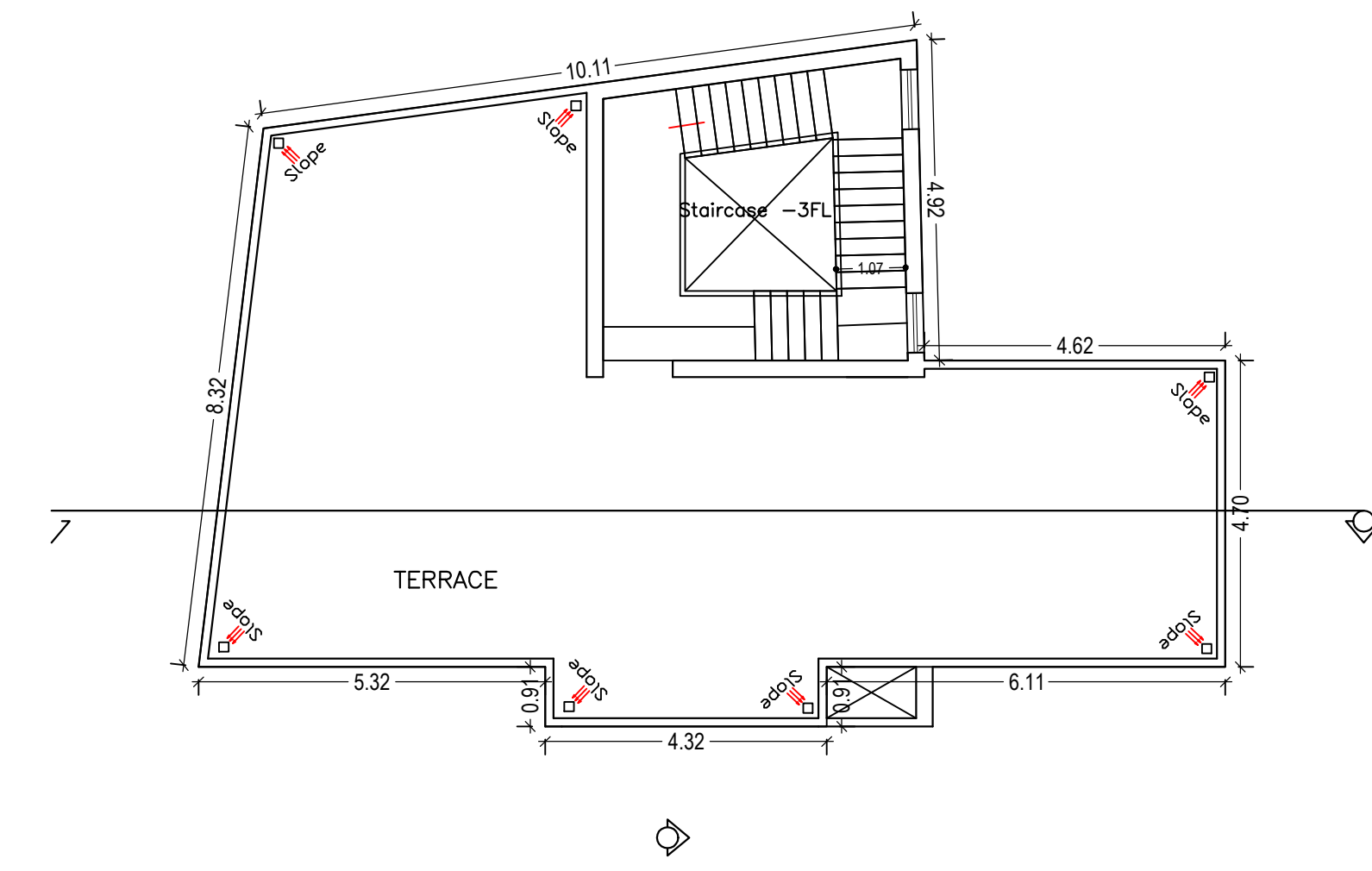

TERRACE FLOOR PLAN
(SCALE 1:100)

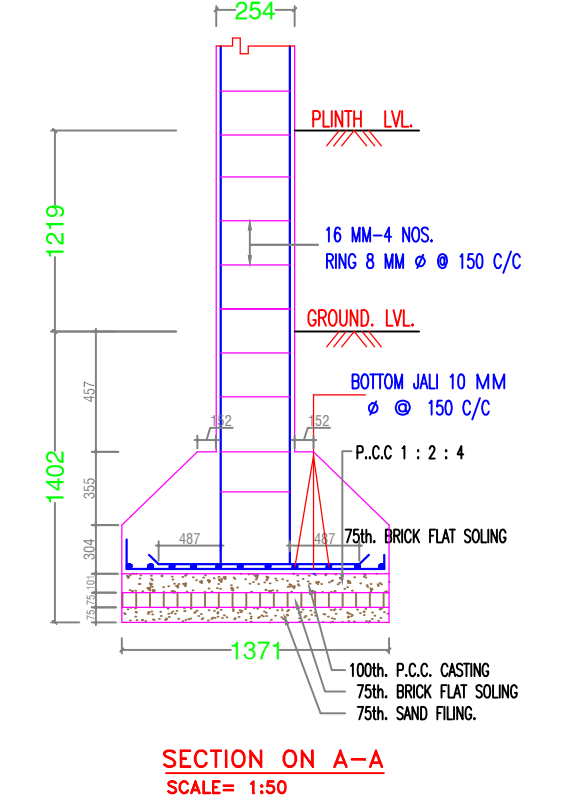

SECTION ON A-A
SCALE= 1:50

LTP NAME AND SIGNATURE	STRUCTURAL ENG'S NAME AND SIGNATURE	BUILDER NAME AND SIGNATURE	DIGITAL SIGNATURE
ASHWINI KUMAR SAHU LNP/ENG/0005/2017			