

Project Title :SMT ARCHANA SAHU

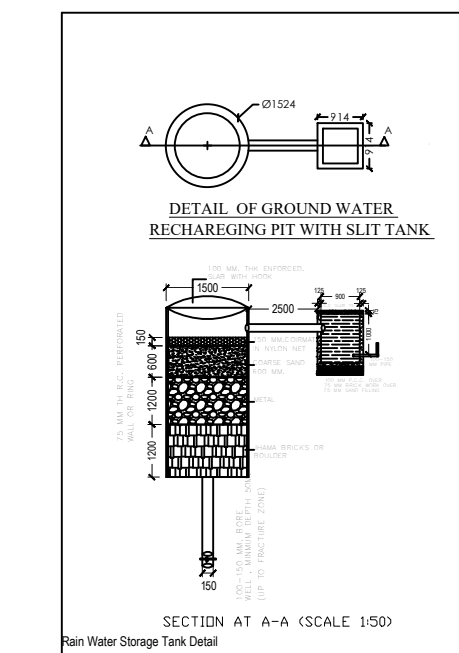
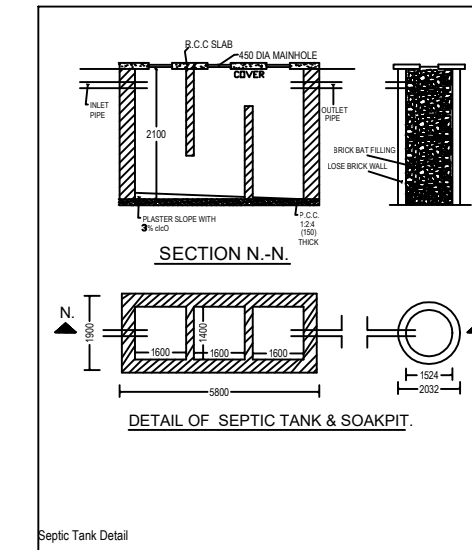
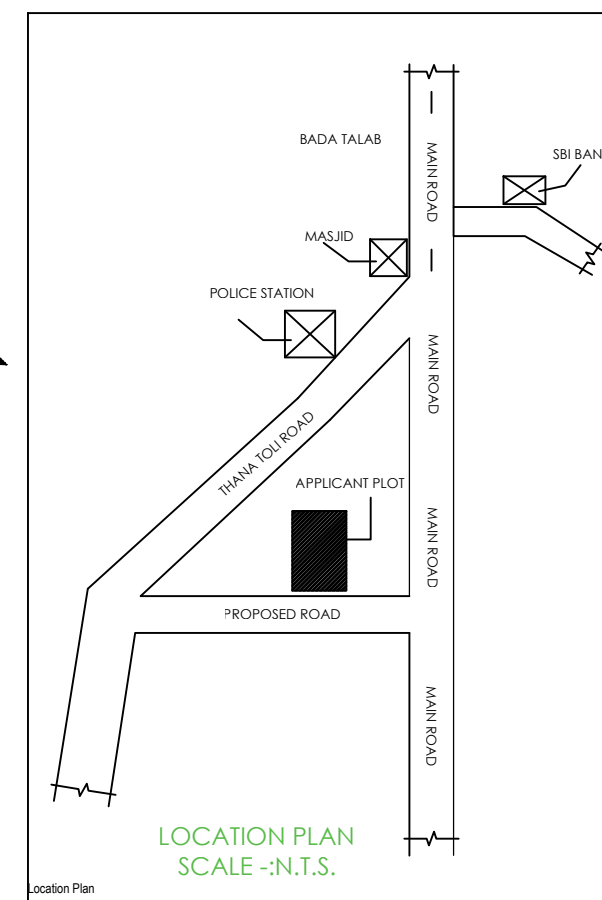
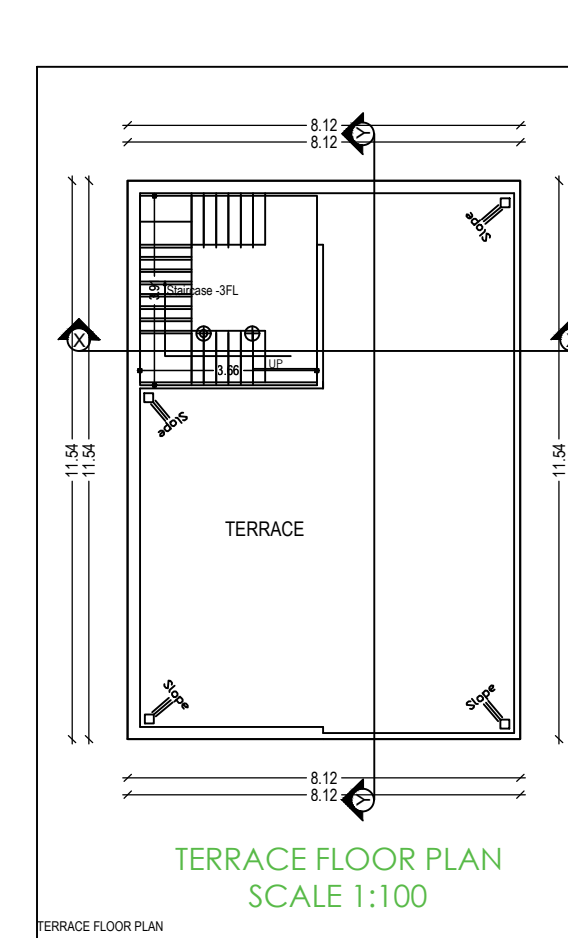
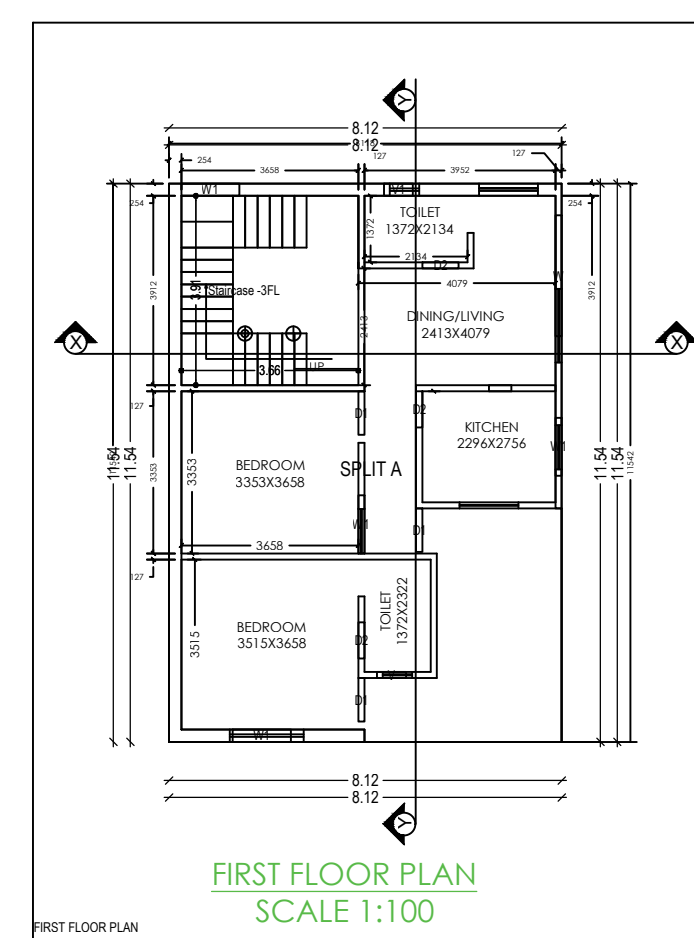
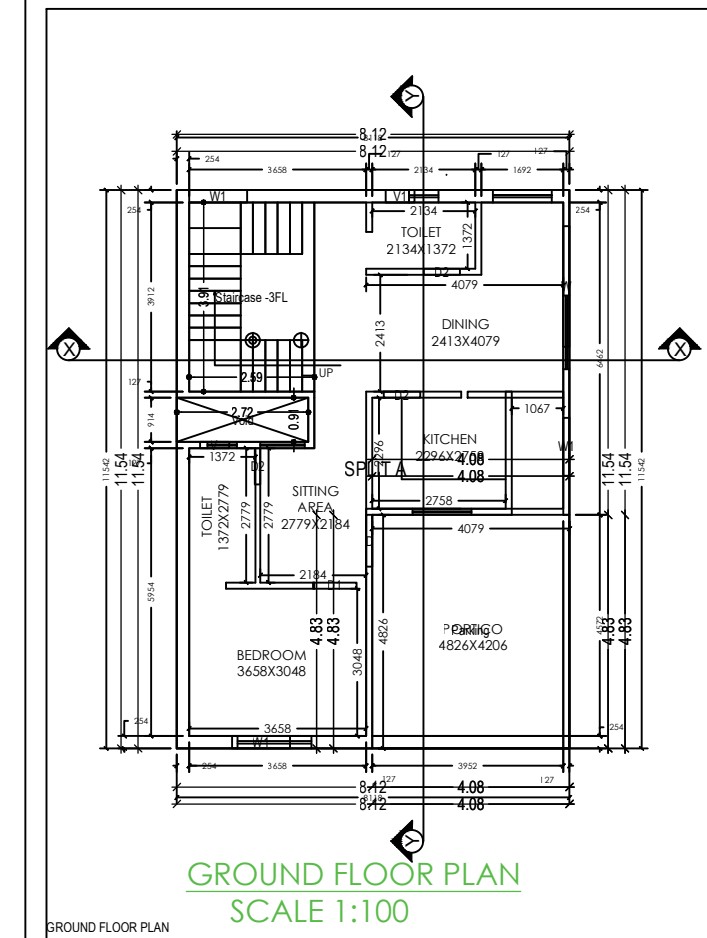
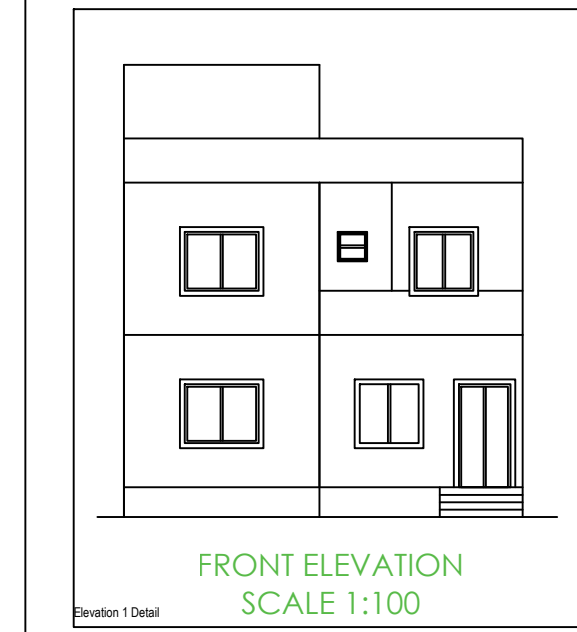
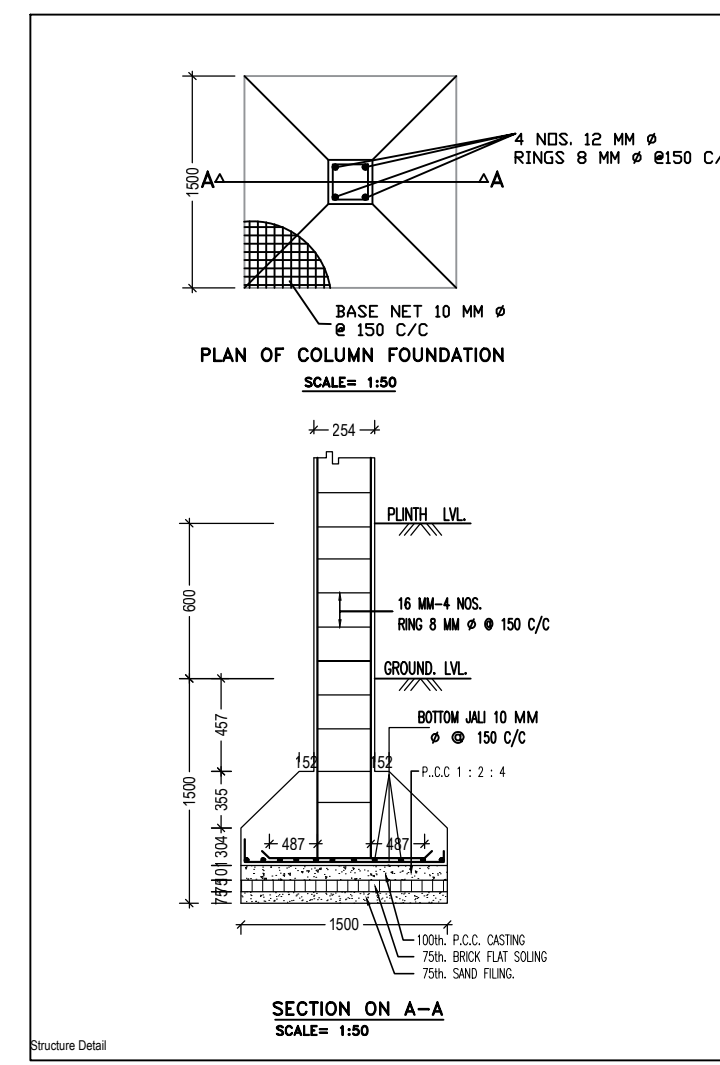
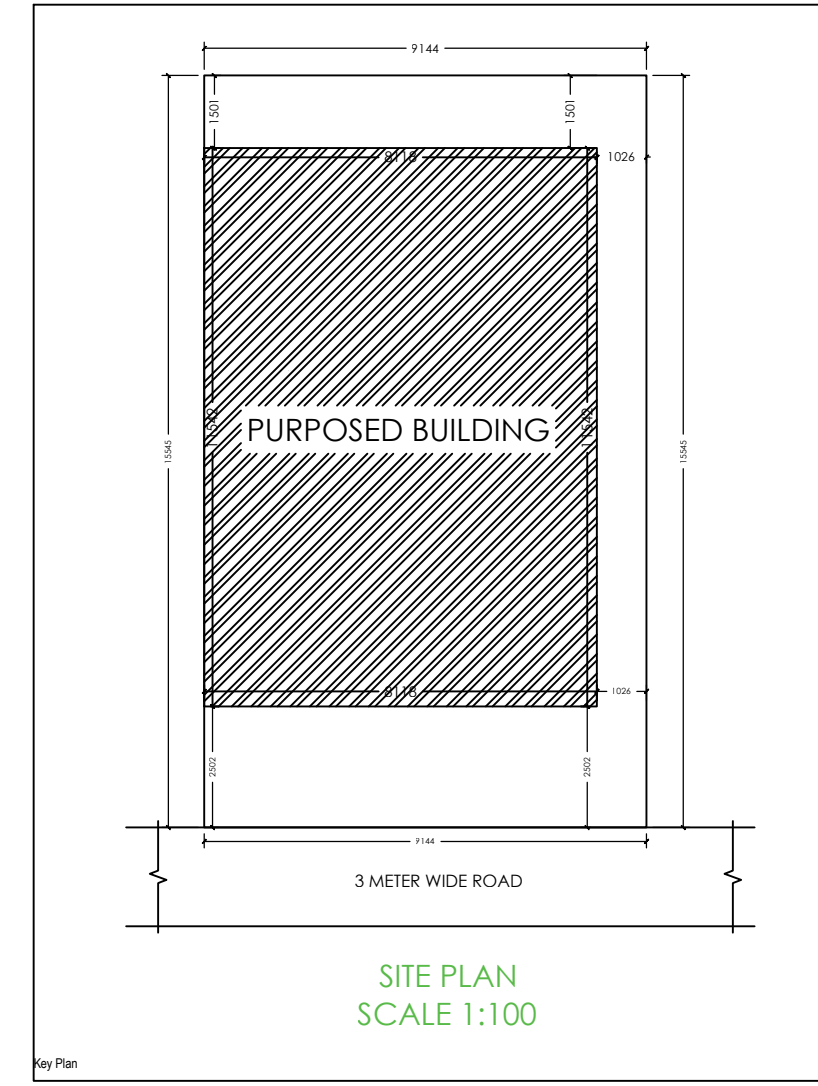
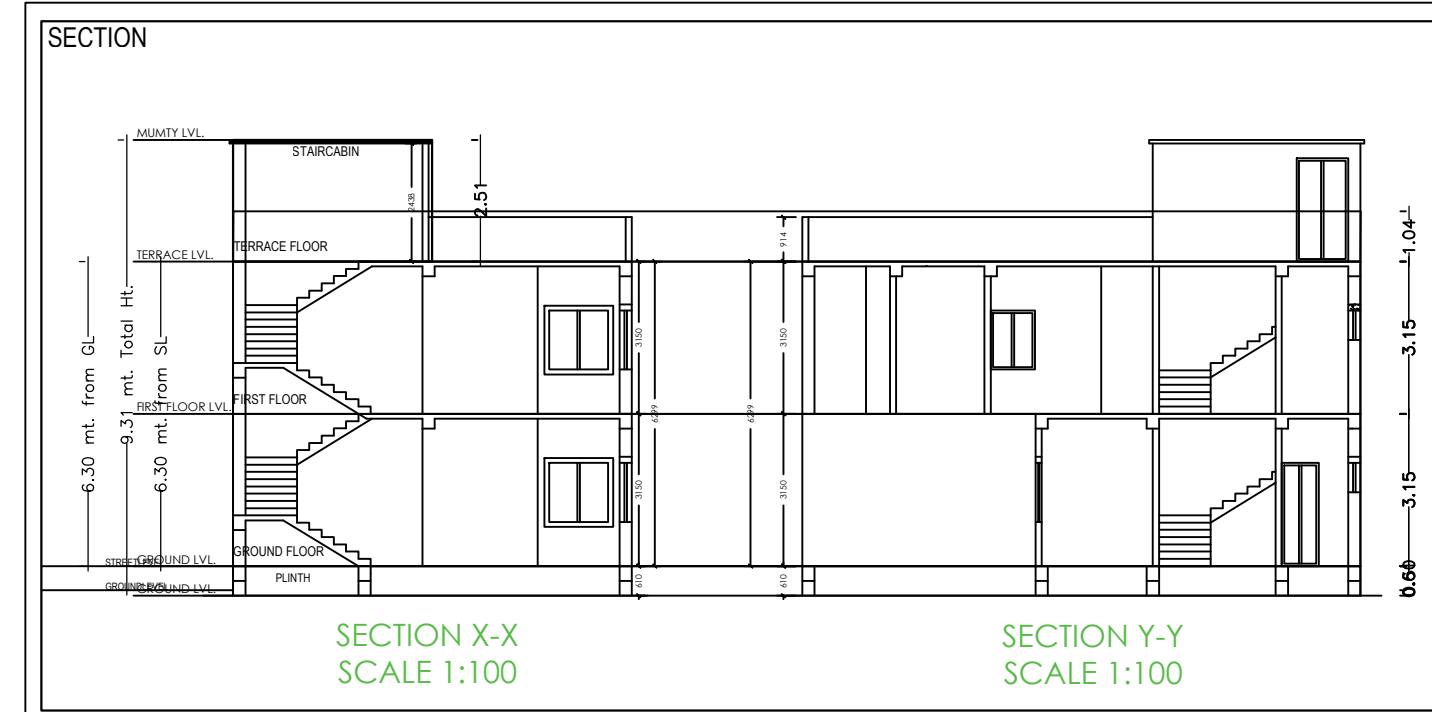

- General notes**
1. ALL DIMENSION ARE IN MILLIMETRES UNLESS OTHERWISE STATED.
 2. NO DIMENSION IS TO BE SCALED OFF THE DRAWING.
 3. DRAWINGS TO BE READ IN CONJUNCTION WITH ALL RELEVANT DRAWINGS & SPECIFICATIONS.
 4. REFER WRITTEN DIMENSIONS ONLY.
 5. DOORS AND WINDOW FRAME NOT TO BE FIXED ALONG WITH BRICK WORK.
 6. INTERNAL PLASTER SHOULD BE 12MM THICK AND EXTERNAL PLASTER IS 25MM THICK.
 7. FOUNDATION DEPTH UP TO GOOD SOIL.
 8. CHEMIST MORTAR OF MIX (1:1) FOR ENTIRE STRUCTURE AND PLASTER WORK.
 9. SEPTIC TANK WILL BE FLUSHING SYSTEM.
 10. ALL REINFORCEMENT SHALL BE OF TOR STEEL OF GRADE FY-413.
 11. GRADE OF CONCRETE SHALL BE M-20.

TYPE	WIDTH	HEIGHT	SILL LVL.	DISCRPTION
D	1000	2100	NILL	SINGLE SHUTTER FLUSH DOOR
D1	1000	2100	NILL	--
D2	900	2100	NILL	--
D3	700	2100	NILL	--
CG	1500	2100	NILL	STEEL CHANNEL GATE
W	1500	1200	900	4 LEAF GLAZED WINDOW
W2	1200	1200	900	--
W3	900	1200	900	--
V	600	300	2400	VENTILATOR

Schedule of area

PLOT AREA AS PER SITE	- 142.19 SQ.M.
AREA OF GROUND FLOOR	- 93.72 SQ.M.
AREA OF FIRST FLOOR	- 93.72 SQ.M.
TOTAL BUILT UP AREA	- 187.44
% COVERED AREA	- 65.91%
TOTAL F.A.R. ACHIEVED	- 1.31

PROPOSED RESIDENTIAL BUILDING PLAN OF SMT ARCHANA SAHU, W/O ALOK SAHU, RS. PLOT NO. - 1342, KHATA NO. ---, THANA NO.-194, WARD NO.- 12, AREA 3.5 DECIMALS, MAUZA- LOHARDAGA, THANA - LOHARDAGA, DIST- LOHARDAGA - 835302, STATE - JHARKHAND

ISSUE ONLY FOR CLIENT

SCALE	DATE	SHEET NO.
1 : 100	01/07/01	01 OF 01

CLIENT: _____ ENGINEER / ARCHITECT: _____

AREA STATEMENT: LOHARDAGA NAGAR PARISHAD	VERSION NO. : 1.0.18
PROJECT DETAIL	VERSION DATE: 30/06/2018
Plot No. : _____	Plot Use: Residential
Region: JHARKHAND (RURAL LOCAL BODIES)	Plot Scale: Residential Bldg/Apartment
District: LOHARDAGA	Land Use Zone: NA
Application Type: General Proposal	Abutting Road Width: -
Project Type: Building Permission	Plot No.:
Nature of Development: New	Revenue Survey No./Survey No.:
Location: Old Area	Thana No.:
SOB Location: NA	Ward No.:
Village/Mauza Name: -	Khata No.:
Ward No.:	North -
Road/Street: -	South -
	East -
	West -

AREA DETAILS:

AREA OF PLOT (Minimum)	(A)	SQ.MT.	142.14
Net Plot Area (Gross Plot Area - Deduction from Gross Plot Area)	(A-Deductions)		142.14
Conditions for Balance Plot Area (from Gross Plot Area)			
COF Area			15.14
Total			15.14
Balance Plot Area (Net Plot Area - Recreational/Amenity spaces)	(A-Deductions)		126.01
Plot Area for Coverage (Net Plot Area - Recreational/Amenity spaces)	(A-Deductions)		142.14
Plot Area for FSI (Net Plot Area - Recreational/Amenity spaces)	(A-Deductions)		142.14
Accessory Use Area			0.00

COVERAGE CHECK

Proposed Coverage Area (65.91%)	93.69
Total Coverage Area (65.91%)	93.69

FAR CHECK

Proposed Area of FAR	184.90
Total Area of FAR	184.90

BUILT UP AREA CHECK

Total Proposed Built Up Area	207.08
ARCH/ENGR/SUPERVISOR (Sign)	OWNER

DEVELOPMENT AUTHORITY LOCAL BODY

COLOR INDEX

Color	Symbol
Proposed Work (Coverage Area)	[Hatched Box]
Existing (To be retained)	[Solid Box]
Existing (To be demolished)	[Dotted Box]

PARKING CALCULATION:

Parking Type	Prop No.	Prop Area
Other Parking	2	42.53
Total Area	2	42.53

MARGIN DETAIL:

Bldg/Wing Name	Road Name	Front Margin	Rear Margin	Side1 Margin	Side2 Margin
A/SMT ARCHANA SAHU	V.V. METER WIDE ROAD	2.50	1.50	0.00	1.03

FAR & Tenement Details (Table 4c-1)

Building	No. of Same Bldg	Total Built Up Area (Sq.m.)	Deductions (Area in Sq.m.)	Proposed FAR Area (Sq.m.)	Total FAR Area (Sq.m.)	Tenm (No.)
A/SMT ARCHANA SAHU	1	207.08	2.49	19.69	184.90	01
Grand Total	1	207.08	2.49	19.69	184.90	01

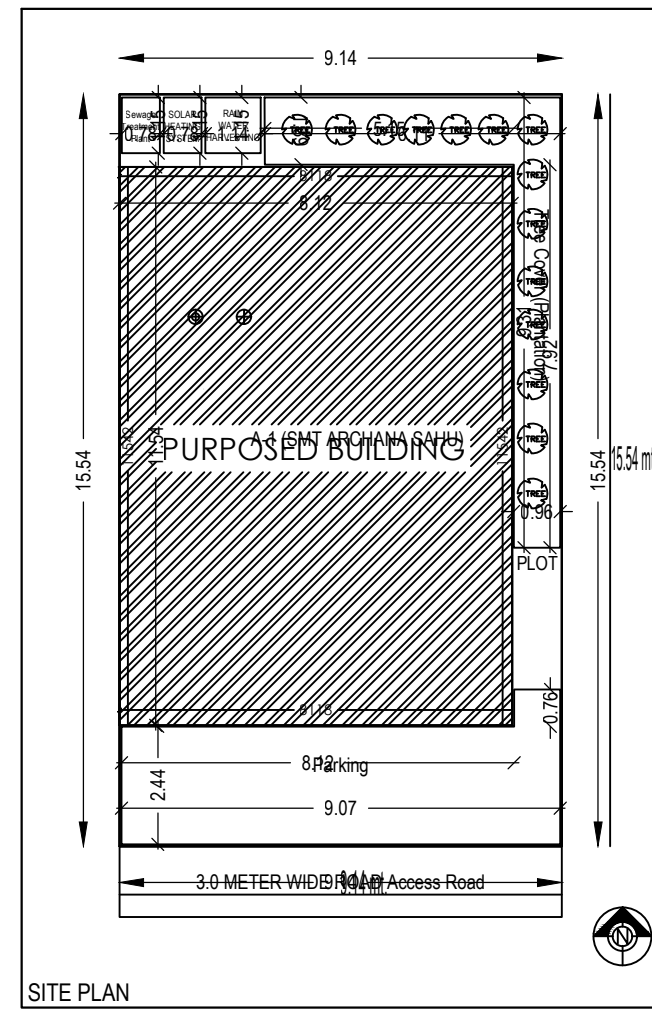

Building -A (SMT ARCHANA SAHU)

Floor Name	Total Built Up Area (Sq.m.)	Deductions (Area in Sq.m.)	Proposed FAR Area (Sq.m.)	Total FAR Area (Sq.m.)	Tenm (No.)
Ground Floor	113.38	2.49	19.69	91.21	01
First Floor	93.69	0.00	0.00	93.69	00
Terrace Floor	0.00	0.00	0.00	0.00	00
Total	207.08	2.49	19.69	184.90	01

SCHEDULE OF JOINERY:

BUILDING NAME	NAME	LENGTH	HEIGHT	NOS
A (SMT ARCHANA SAHU)	G2	0.75	2.13	06
A (SMT ARCHANA SAHU)	D1	0.90	2.13	04
A (SMT ARCHANA SAHU)	D	1.07	2.13	01
Total	-	-	-	11

SCHEDULE OF JOINERY:

BUILDING NAME	NAME	LENGTH	HEIGHT	NOS
A (SMT ARCHANA SAHU)	V1	0.60	1.00	02
A (SMT ARCHANA SAHU)	V	0.60	1.00	02
A (SMT ARCHANA SAHU)	W1	1.20	2.50	04
A (SMT ARCHANA SAHU)	W1	1.20	2.70	03
A (SMT ARCHANA SAHU)	W	2.50	2.50	02
Total	-	-	-	13

UnitBUA Table for Building -A (SMT ARCHANA SAHU)

FLOOR	Name	UnitBUA Type	UnitBUA Area	Capital Area	No. of Rooms	No. of Tenement
GROUND FLOOR	SPLIT A	FLAT	124.74	124.31	5	1
Total	-	-	124.74	124.31	12	1