



SIDE ELEVATION  
(SCALE 1:100)

FRONT ELEVATION  
(SCALE 1:100)

**COLOR INDEX**

PLOT BOUNDARY	Black
ABUTTING ROAD	Green
PROPOSED CONSTRUCTION	Red
COMMON PLOT	Yellow
ROAD WIDENING AREA	Blue
EXISTING (To be retained)	Orange
EXISTING (To be demolished)	Light Blue

FAR & Tenement Details (Table 4c-1)

Building	No. of Same Bldg	Total Built Up Area (Sq.mt.)	Proposed FAR Area (Sq.mt.) Resi.	Total FAR Area (Sq.mt.)	Total Consumed Additional FAR Area (Sq.mt.)	Tnmt (No.)
A (SANJEET KUMAR SAHU)	1	130.00	130.00	130.00	130.00	01
Grand Total:	1	130.00	130.00	130.00	130.00	01

Buildingwise Floor FAR Details

Floor Name	Building Name A (SANJEET KUMAR SAHU)		Total	
	Proposed Built Up Area (Sq.mt.)	Proposed FAR Area (Sq.mt.)	Total Proposed Built Up Area (Sq.mt.)	Total FAR Area (Sq.mt.)
Ground Floor	65.00	65.00	65.00	65.00
First Floor	65.00	65.00	65.00	65.00
Terrace Floor	0.00	0.00	0.00	0.00
Total:	130.00	130.00	130.00	130.00

UnitBUA Table for Building :A (SANJEET KUMAR SAHU)

FLOOR	Name	UnitBUA Type	UnitBUA Area	Carpet Area	No. of Rooms	No. of Tenement
GROUND FLOOR PLAN	SPLIT A	FLAT	100.81	100.57	6	1
FIRST FLOOR PLAN	SPLIT A	FLAT	0.00	0.00	6	0
Total:	-	-	100.81	100.57	12	1

Building USE/SUBUSE Details

Building Name	Building Use	Building SubUse	Building Structure
A (SANJEET KUMAR SAHU)	Residential	Residential Bldg/Apartment	Non-Highrise

Proposal Basic Information

Proposal File No.	LNP/BP/0027/W15/2018
Owner Name	SANJEET KUMAR SAHU
Khata No	385
Plot No	832
Village Name	Lohardaga
Use	Residential
SubUse	Bungalow/ Dwelling / Non Apartment

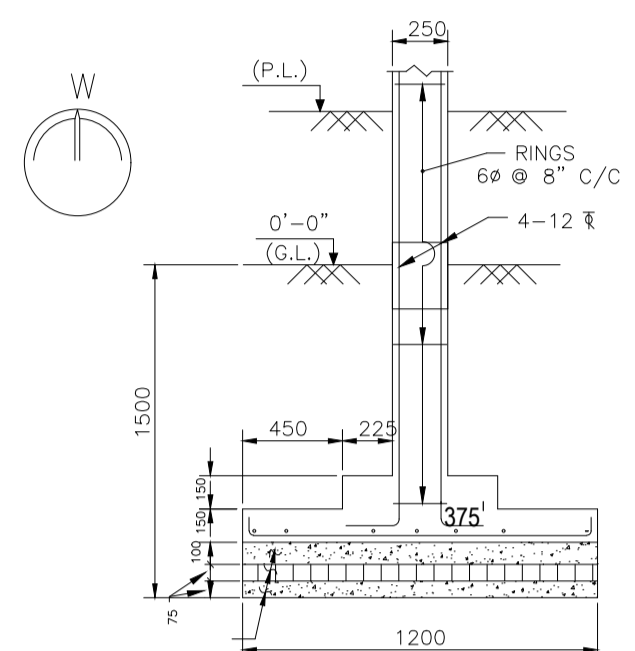

SECTION B-B

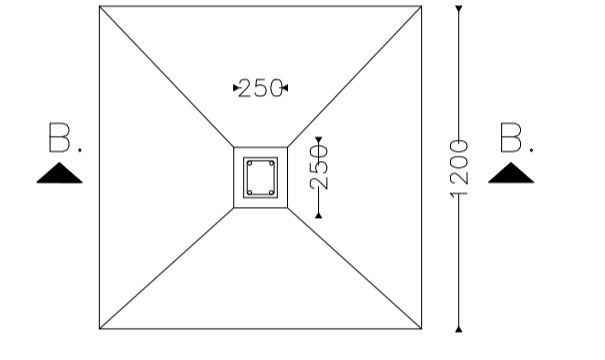

DETAIL OF FOUNDATION

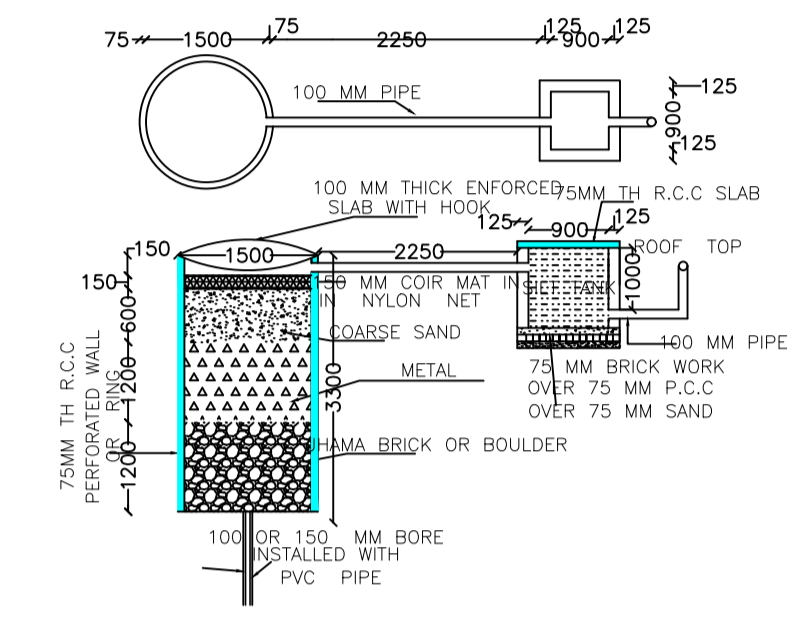

DETAIL OF RECHARGE WELL

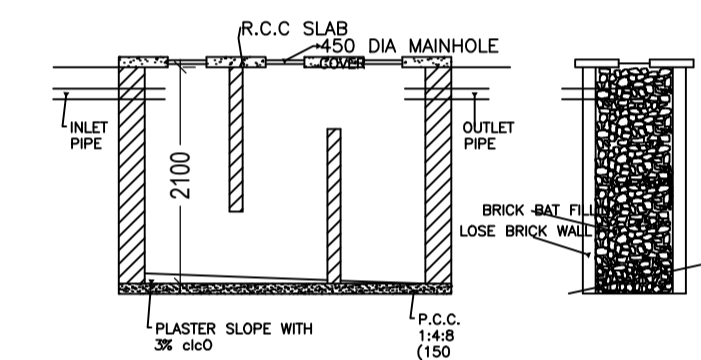

SECTION N-N

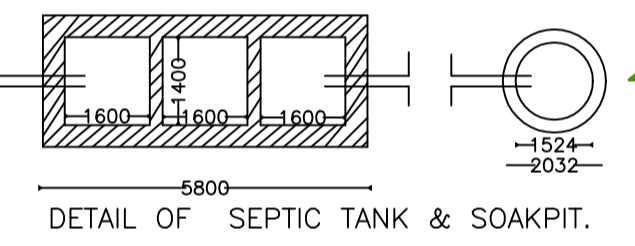

DETAIL OF SEPTIC TANK & SOAKPIT.

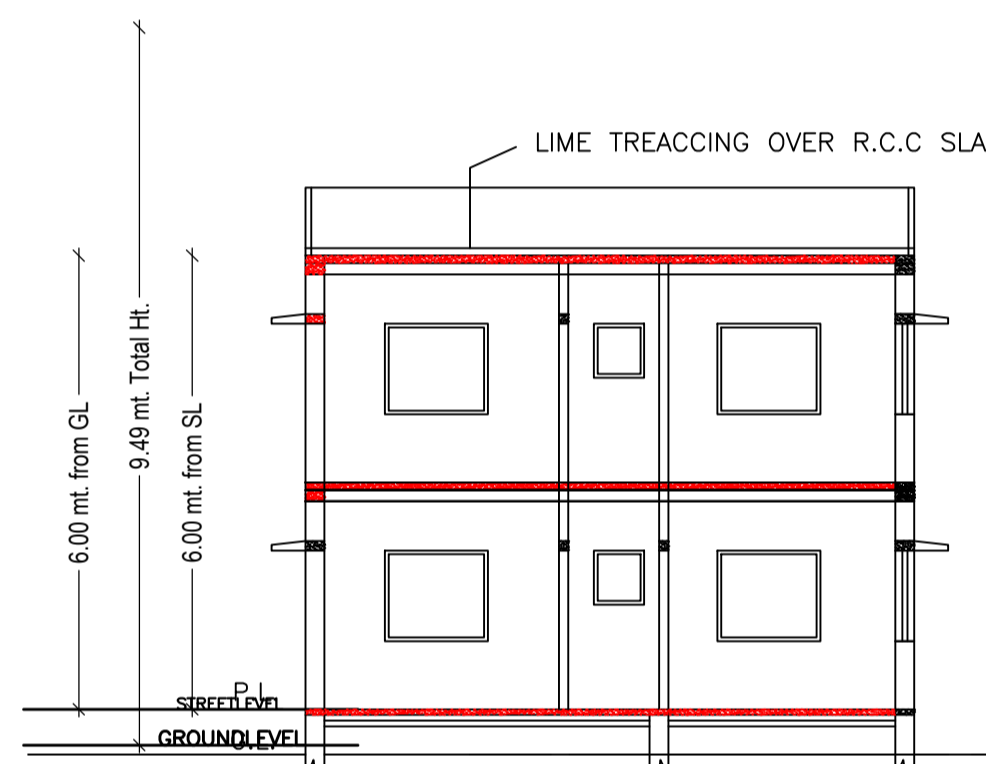

SECTION AT A-A  
(SCALE 1:100)

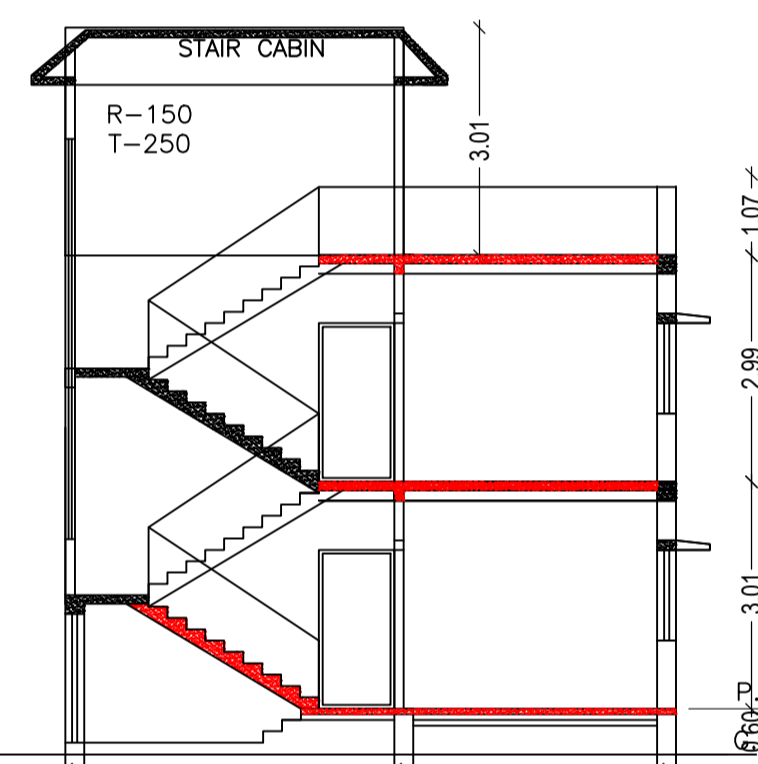

SECTION AT X-X  
(SCALE 1:100)

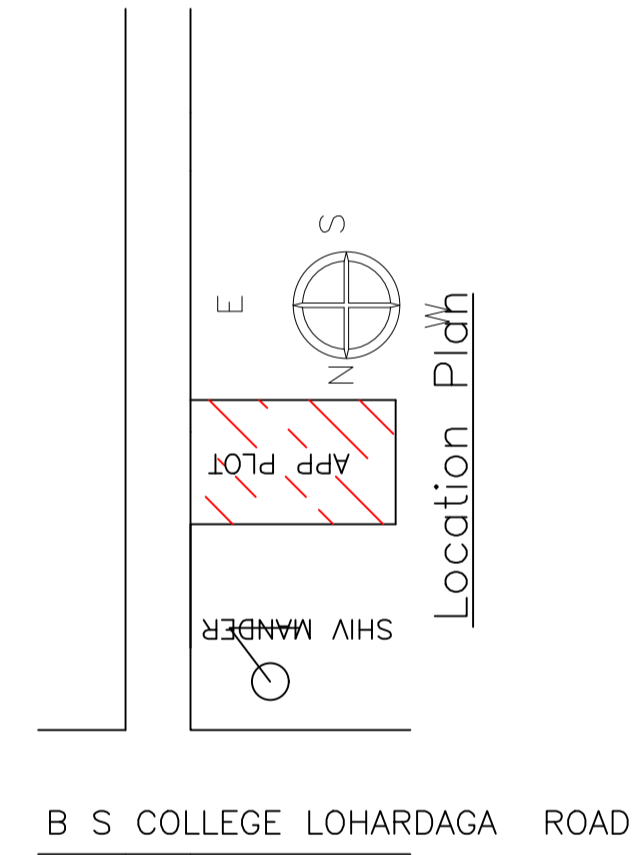

B S COLLEGE LOHARDAGA ROAD

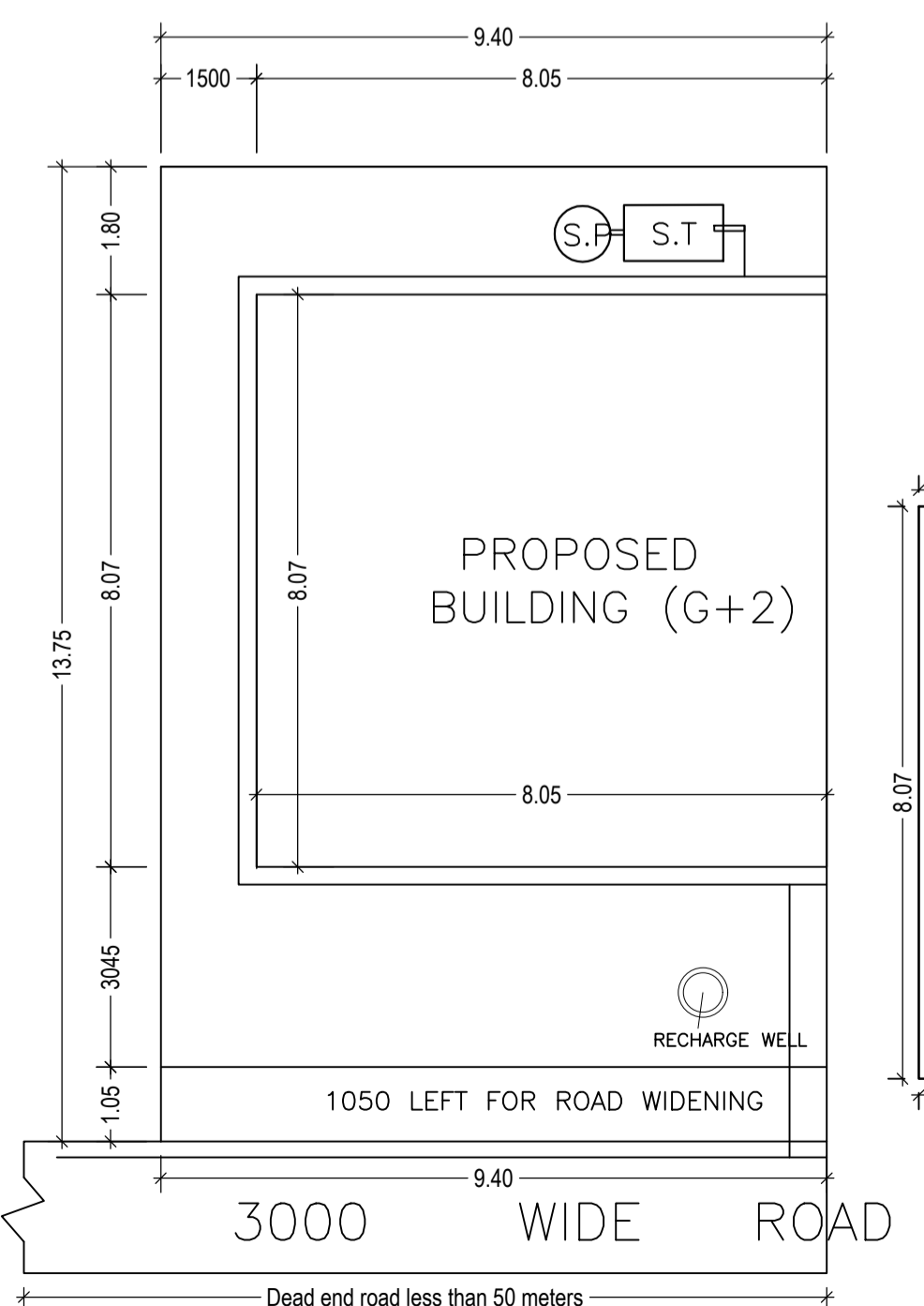

TERRACE FLOOR PLAN  
(SCALE 1:100)

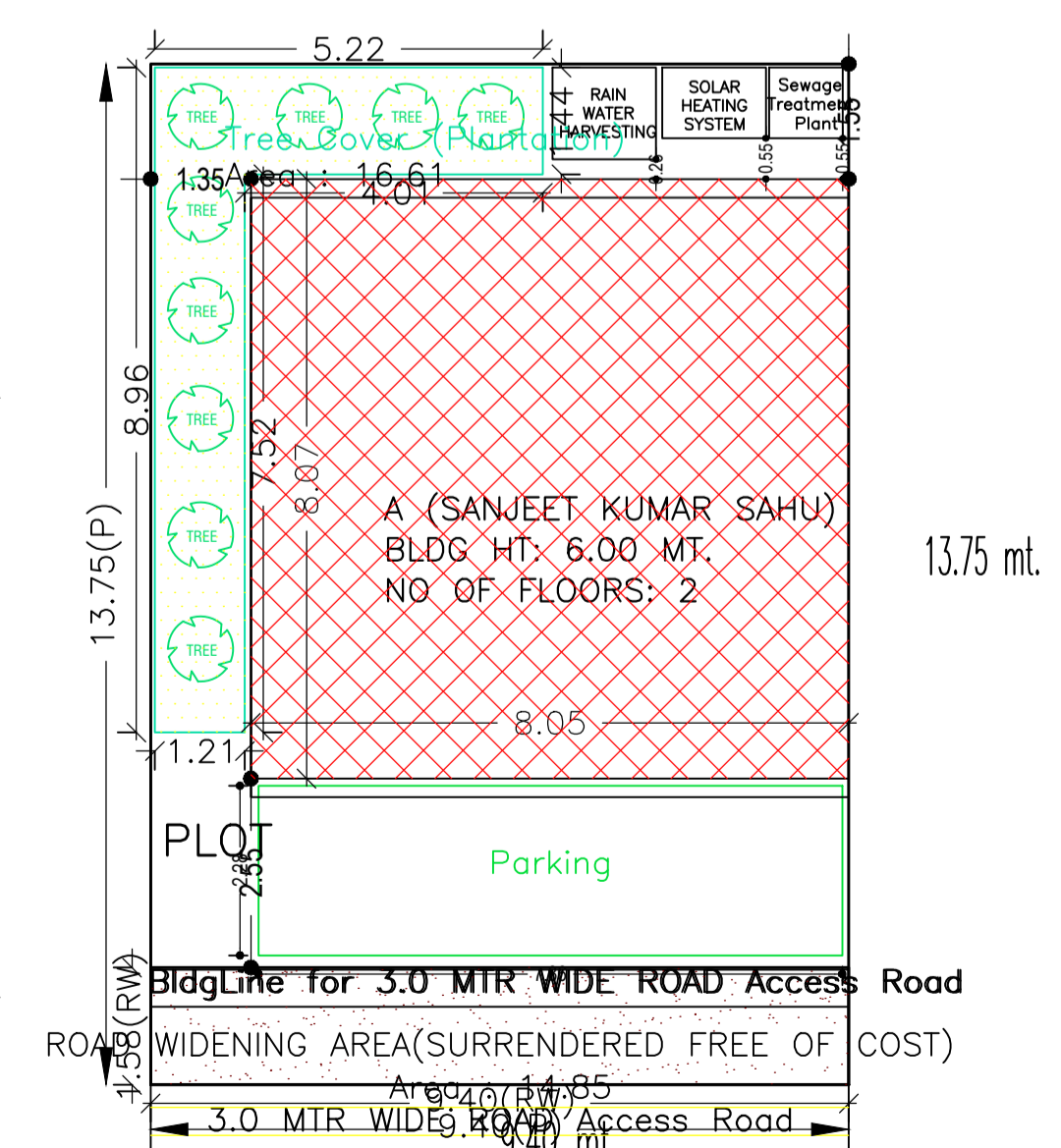

SITE PLAN

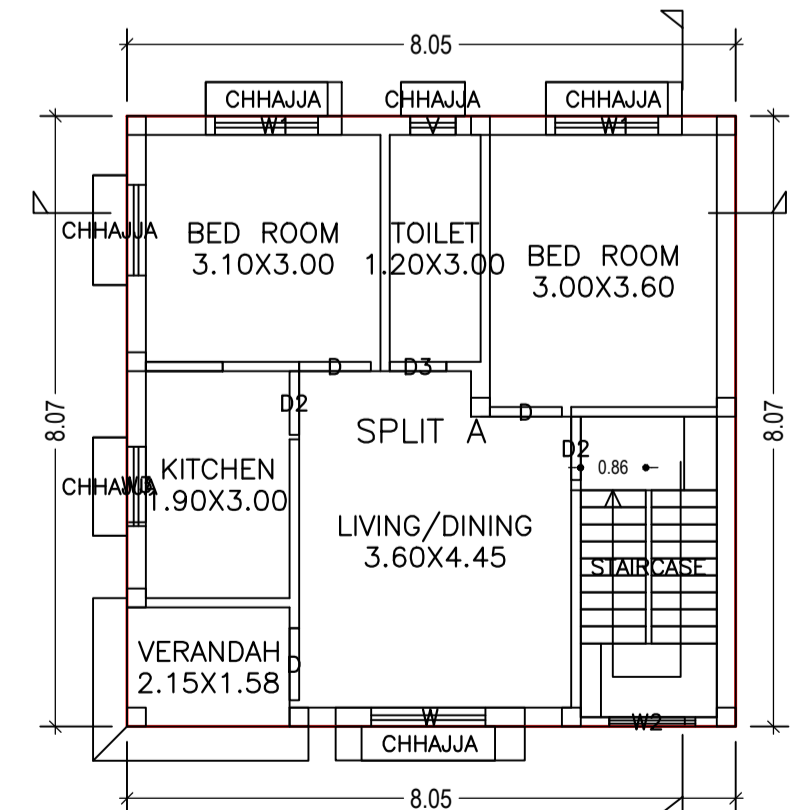

GROUND FLOOR PLAN  
(Proposed)  
(SCALE 1:100)

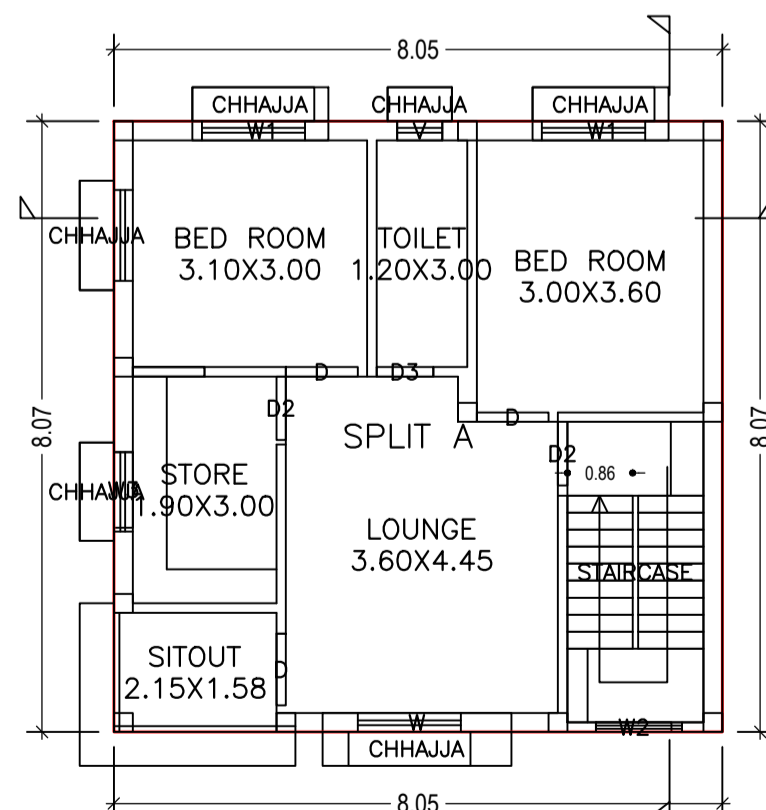

FIRST FLOOR PLAN  
(Proposed)  
(SCALE 1:100)

**AREA STATEMENT**

LOHARDAGA NAGAR  
PARISHAD

PROJECT DETAIL:  
Region: JHARKHAND URBAN LOCAL BODIES  
District: LOHARDAGA  
Authority: LOHARDAGA NAGAR PARISHAD  
Inward No: LNP/BP/0027/W15/2018

Plot Use: Residential  
Plot SubUse: Bungalow/ Dwelling / Non Apartment  
PlotNearby/Religious/Structure: NA  
Plot/SubPlot No: 832

Project Type: Building Permission  
Nature of Development: New  
Location of Development Area: Old Area

AREA DETAILS:	SQ.MT.
AREA OF PLOT (Minimum)	129.25
Surrender Free of Cost	14.85
Total	14.85
NET AREA OF PLOT (Gross Plot Area - Deduction from Gross Plot area)	114.40
Deduction for Balance Plot Area (from Gross Plot Area)	
Surrender Free of Cost	
Common Plot	16.61
Total	31.46
BALANCE AREA OF PLOT (Net Plot Area - Recreational/Amenity space)	97.79
PLOT AREA FOR COVERAGE (Net Plot Area)	114.40
Plot Area for FAR (Net Plot Area + Road/Widening Area)	129.25
COVERAGE CHECK	
Permissible Coverage area (70.00%)	80.08
Proposed Coverage Area (56.82%)	65.00
Total Prop. Coverage Area (56.82%)	65.00
Balance coverage area (13.18%)	15.08
FAR CHECK	
Perm. FAR Area (1.20)	155.10
Total Perm. FAR area	155.10
Residential FAR	130.01
Proposed FAR Area	130.01
Total Proposed FAR Area	130.01
Consumed FAR (Factor)	1.01
Balance FAR Area	25.09
BUILT UP AREA CHECK	
Total Proposed BuiltUp Area	130.00
ARCHITECT (Regd)	SUNIL KUMAR
ENGINEER (Regd)	
SUPERVISOR (Regd)	
OWNER (Regd)	SANJEET KUMAR SAHU
DEVELOPMENT AUTHORITY	LOCAL BODY

**SCHEDULE OF DOOR:**

BUILDING NAME	NAME	LENGTH	HEIGHT	NOS
A (SANJEET KUMAR SAHU)	D3	0.75	2.13	02
A (SANJEET KUMAR SAHU)	D2	0.84	2.13	04
A (SANJEET KUMAR SAHU)	D	0.95	2.13	06

**SCHEDULE OF WINDOW/VENTILATION:**

BUILDING NAME	NAME	LENGTH	HEIGHT	NOS
A (SANJEET KUMAR SAHU)	V	0.60	2.70	02
A (SANJEET KUMAR SAHU)	W3	1.00	2.70	02
A (SANJEET KUMAR SAHU)	W2	1.00	2.70	02
A (SANJEET KUMAR SAHU)	W1	1.80	2.70	04
A (SANJEET KUMAR SAHU)	W	2.50	2.70	02

Building :A (SANJEET KUMAR SAHU)

Floor Name	Total Built Up Area (Sq.mt.)	Proposed FAR Area (Sq.mt.) Resi.	Total FAR Area (Sq.mt.)	Total Consumed Additional FAR Area (Sq.mt.)	Tnmt (No.)
Ground Floor	65.00	65.00	65.00	65.00	01
First Floor	65.00	65.00	65.00	65.00	00
Terrace Floor	0.00	0.00	0.00	0.00	00
Total:	130.00	130.00	130.00	130.00	01
Total Number of Same Buildings	1				
Total:	130.00	130.00	130.00	130.00	01

LTP NAME AND SIGNATURE	STRUCTURAL ENG'S NAME AND SIGNATURE	BUILDER NAME AND SIGNATURE	DIGITAL SIGNATURE
SUNIL KUMAR LNP/ENG/0004/2017			