

SITE PLAN

FAR & Tenement Details (Table 4c-1)

Building	No. of Same Bldg	Total Built Up Area (Sq.mt.)	Proposed FAR Area (Sq.mt.) Resi.	Total FAR Area (Sq.mt.)	Total Consumed Additional FAR Area (Sq.mt.)	Tnmt (No.)
A (SMT SONY RESHMA DEVI)	1	109.06	109.06	109.06	109.06	01
Grand Total :	1	109.06	109.06	109.06	109.06	01

Proposal Basic Information	
Proposal File No.	LNP/BI/0029/W16/2019
Owner Name	SONY RESHMA DEVI
Khata No	313
Plot No	490/2321,916/3088
Village Name	Lohardaga
Use	Residential
SubUse	Bungalow/ Dwelling / Non Apartment

AREA STATEMENT		VERSION NO. : 1.0.50
LOHARDAGA NAGAR PARISHAD		VERSION DATE: 16/10/2020
PROJECT DETAIL:		
Region: JHARKHAND URBAN LOCAL BODIES	Plot Use: Residential	
District: LOHARDAGA	Plot SubUse: Bungalow/ Dwelling / Non Apartment	
Authority: LOHARDAGA NAGAR PARISHAD	PlotNearbyReligiousStructure: NA	
Inward No: LNP/BI/0029/W16/2019	Plot/SubPlot No: 490/2321,916/3088	
Application Type: General Proposal	North: Plot No. -912	
Project Type: Building Permission	South: Road Width - 2.44	
Nature of Development: New	East: Plot No. - 916/3088	
Location of Development Area: Old Area	West: Plot No. - 916/3088	
AREA DETAILS:		
AREA OF PLOT (Minimum)	(A)	SQ.MT. 119.31
Deduction for NetPlot Area		
Surrender Free of Cost		21.31
Total		21.31
NET AREA OF PLOT(Gross Plot Area - Deduction from Gross Plot area)		
(A-Deductions)		98.00
Deduction for Balance Plot Area(from Gross Plot Area)		
Surrender Free of Cost		21.31
Common Plot		15.55
Total		36.85
BALANCE AREA OF PLOT(Net Plot Area - Recreational/Amenity space)		
(A-Deductions)		62.45
PLOT AREA FOR COVERAGE(Net Plot Area)		
(A-Deductions)		98.00
Plot Area for FAR (Net Plot Area + RoadWidening Area)		
(A-Deductions)		119.31
COVERAGE CHECK		
Permissible Coverage area (70.00 %)		68.60
Proposed Coverage Area (55.64 %)		54.53
Total Prop. Coverage Area (55.64 %)		54.53
Balance coverage area (14.36 %)		14.07
FAR CHECK		
Perm. FAR Area (1.20)		143.17
Total Perm. FAR area		143.17
Residential FAR		109.06
Proposed FAR Area		109.06
Total Proposed FAR Area		109.06
Consumed FAR (Factor)		0.91
Balance FAR Area		34.11
BUILT UP AREA CHECK		
Total Proposed BuiltUp Area		109.06
ARCHITECT (Regd)	ASHWINI KUMAR SAHU	
ENGINEER (Regd)		
SUPERVISOR (Regd)		
OWNER (Regd)	SONY RESHMA DEVI	
DEVELOPMENT AUTHORITY		LOCAL BODY

COLOR INDEX	
PLOT BOUNDARY	Black
ABUTTING ROAD	Green
PROPOSED CONSTRUCTION	Red
COMMON PLOT	Yellow
ROAD WIDENING AREA	Orange
EXISTING (To be retained)	Blue
EXISTING (To be demolished)	Light Blue

Buildingwise Floor FAR Details

Floor Name	Building Name		Total	
	Proposed Built Up Area (Sq.mt.)	Proposed FAR Area (Sq.mt.)	Total Proposed Built Up Area (Sq.mt.)	Total FAR Area (Sq.mt.)
Ground Floor	54.53	54.53	54.53	54.53
First Floor	54.53	54.53	54.53	54.53
Terrace Floor	0.00	0.00	0.00	0.00
Total :	109.06	109.06	109.06	109.06

Building USE/SUBUSE Details

Building Name	Building Use	Building SubUse	Building Structure
A (SMT SONY RESHMA DEVI)	Residential	Bungalow/ Dwelling / Non Apartment	Non-Highrise

LTP NAME AND SIGNATURE	STRUCTURAL ENG'S NAME AND SIGNATURE	BUILDER NAME AND SIGNATURE	DIGITAL SIGNATURE
ASHWINI KUMAR SAHU LNP/ENG/0005/2017			

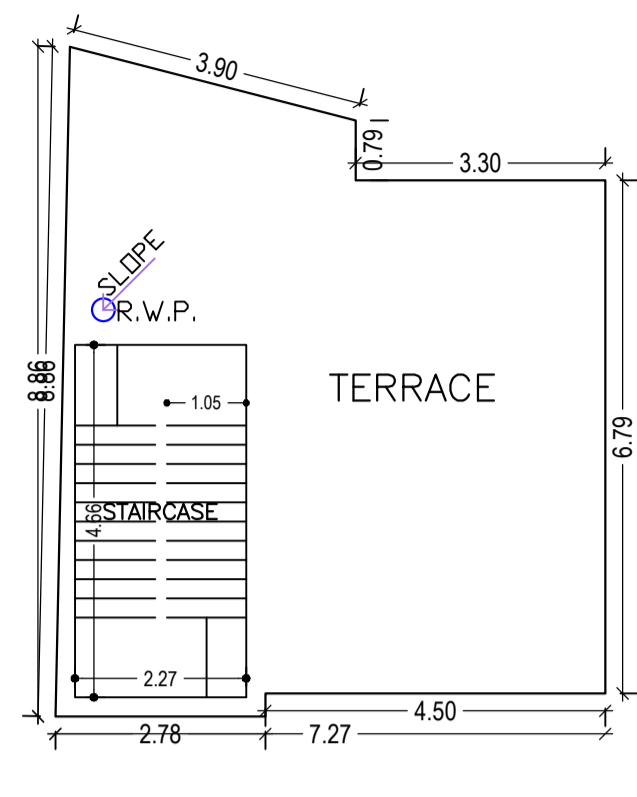
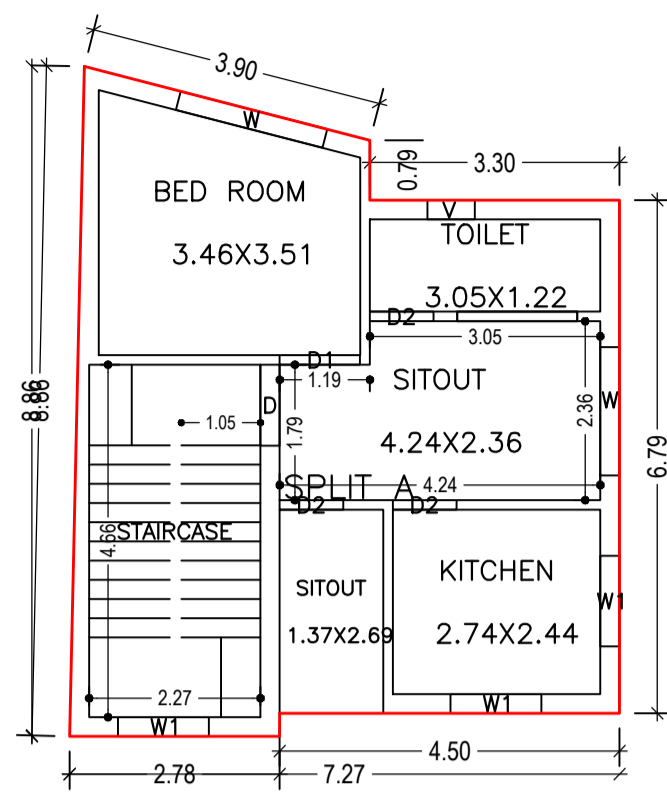

GROUND FLOOR PLAN (Proposed) (SCALE 1:100)

TERRACE FLOOR PLAN (SCALE 1:100)

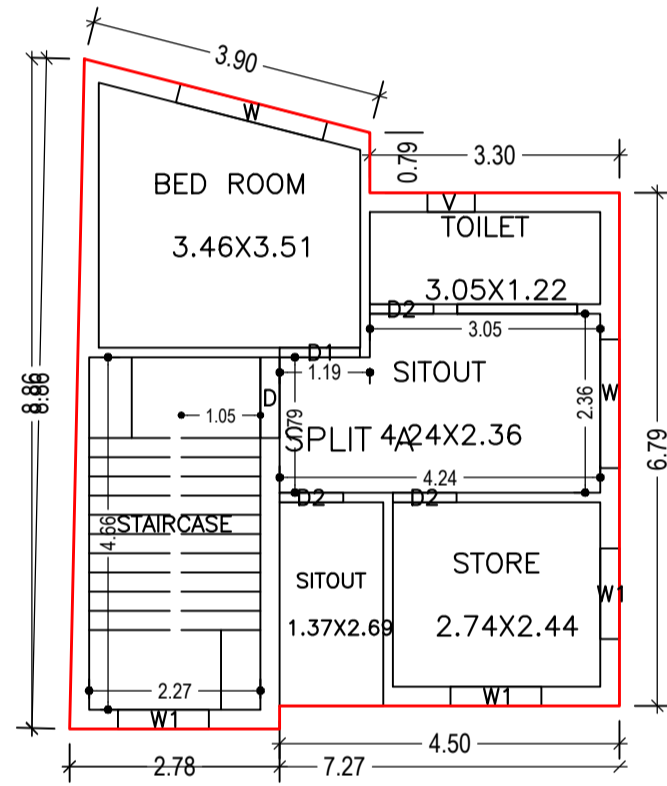

FIRST FLOOR PLAN (Proposed) (SCALE 1:100)

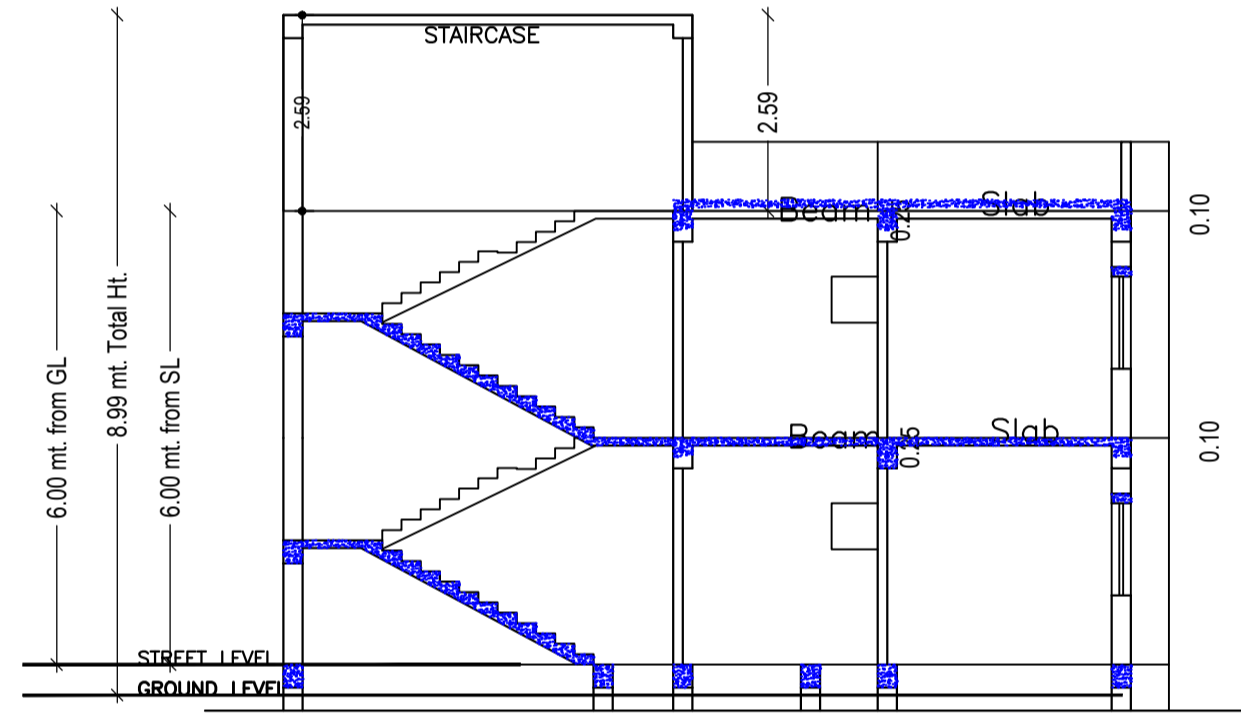

SECTION X-X Scale - 1:100

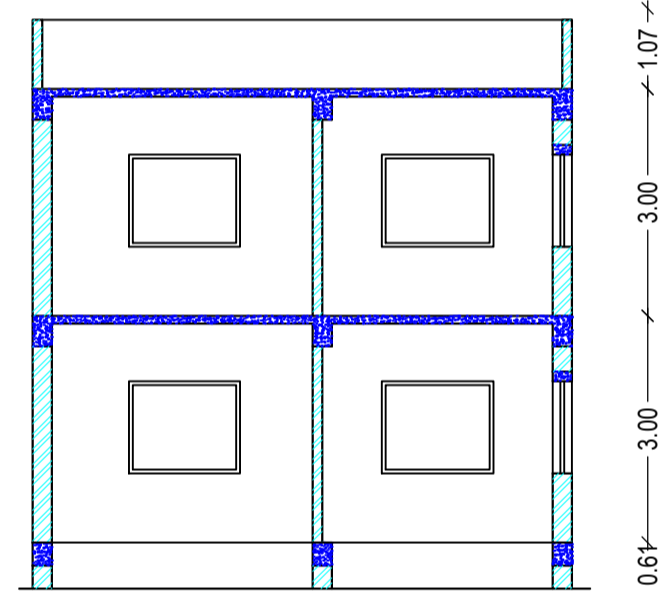

SECTION Y-Y Scale - 1:100

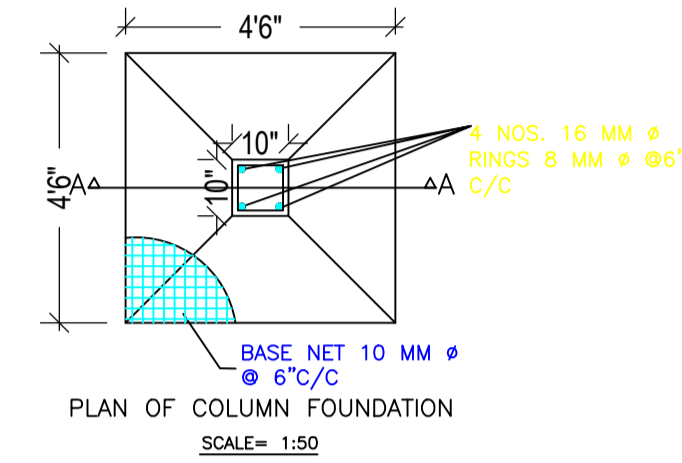

PLAN OF COLUMN FOUNDATION SCALE= 1:50

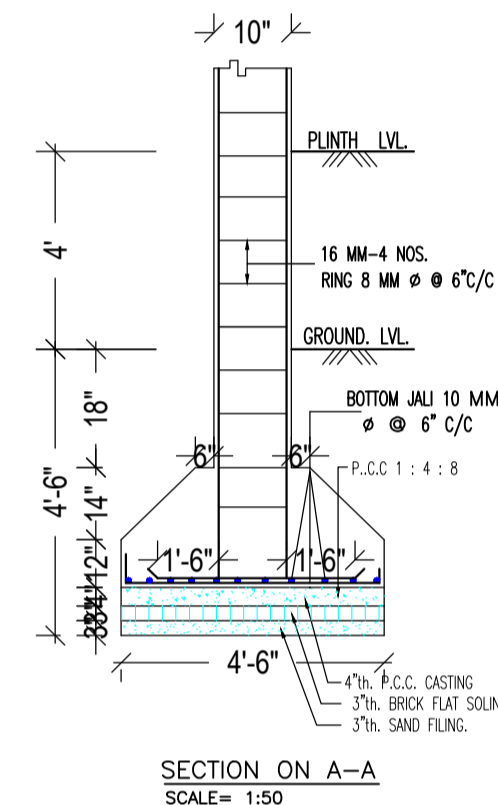

SECTION ON A-A SCALE= 1:50

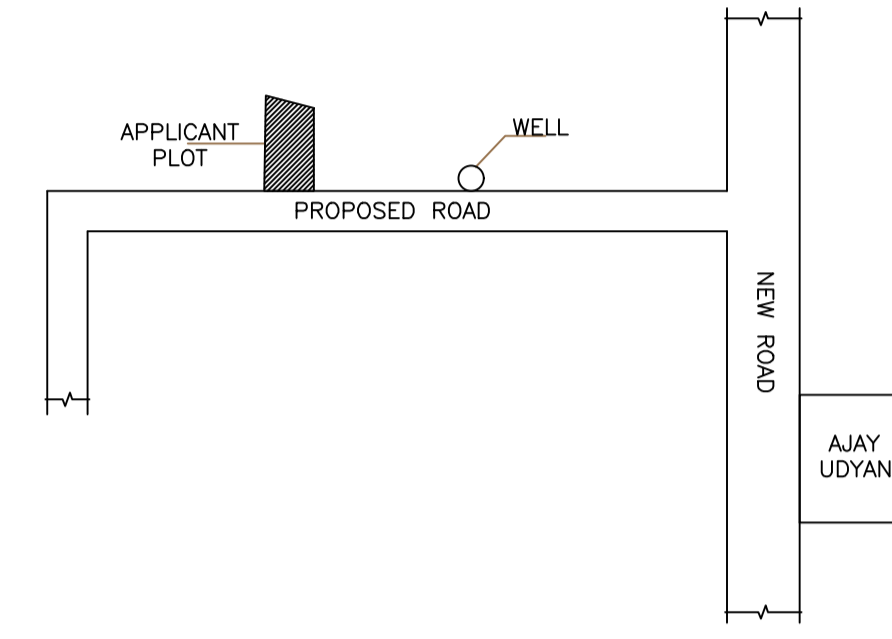

LOCATION PLAN Scale - N.T.S.

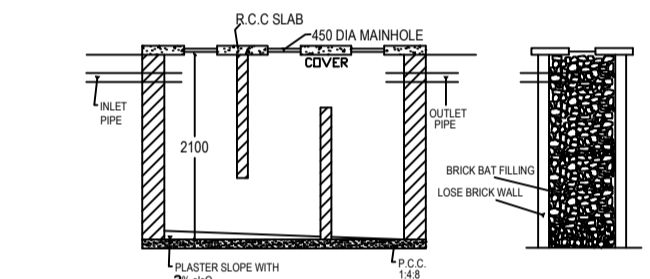

SECTION N-N

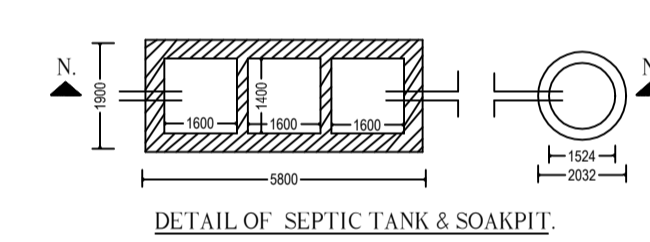

DETAIL OF SEPTIC TANK & SOAKPIT

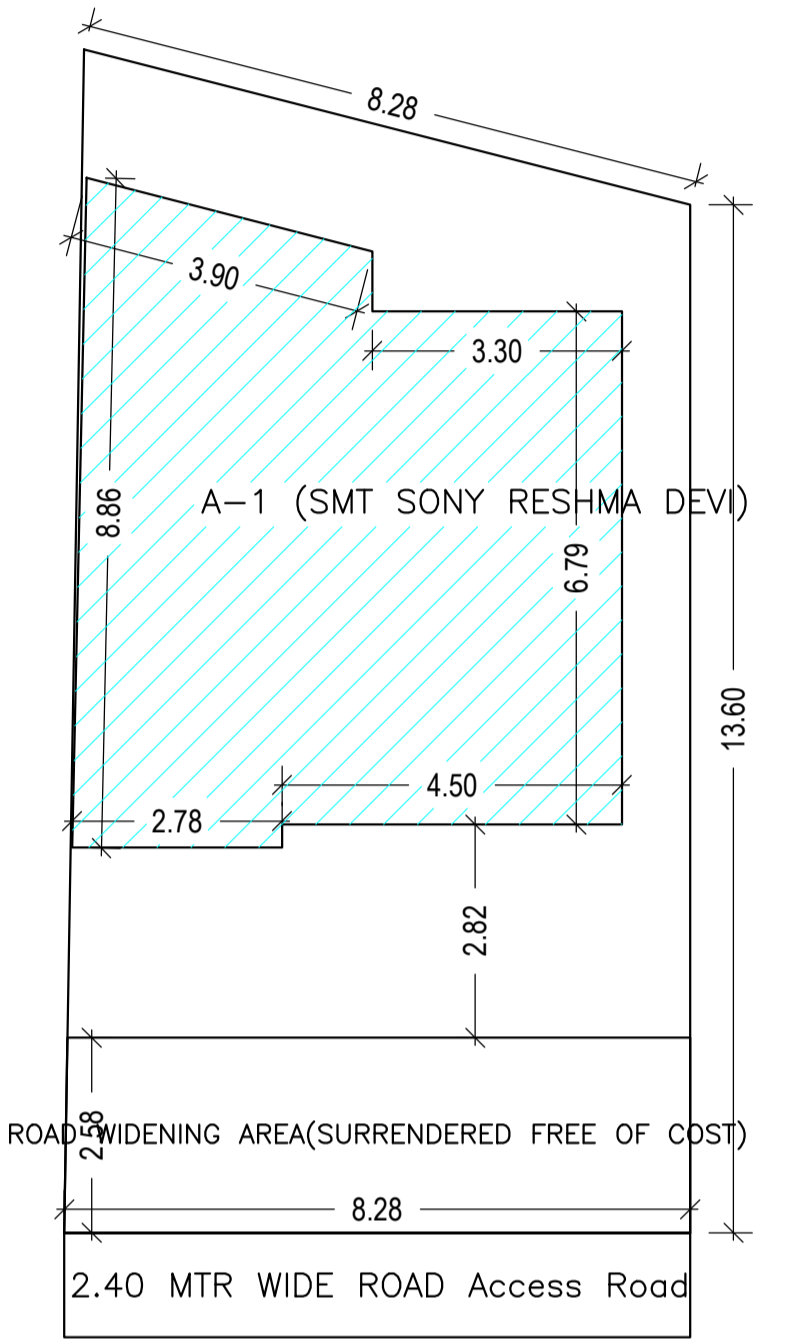

SITE PLAN Scale - 1:100

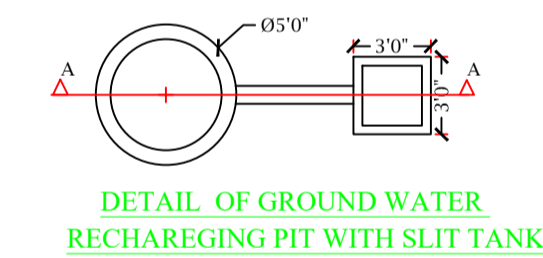

DETAIL OF GROUND WATER RECHARGING PIT WITH SLIT TANK

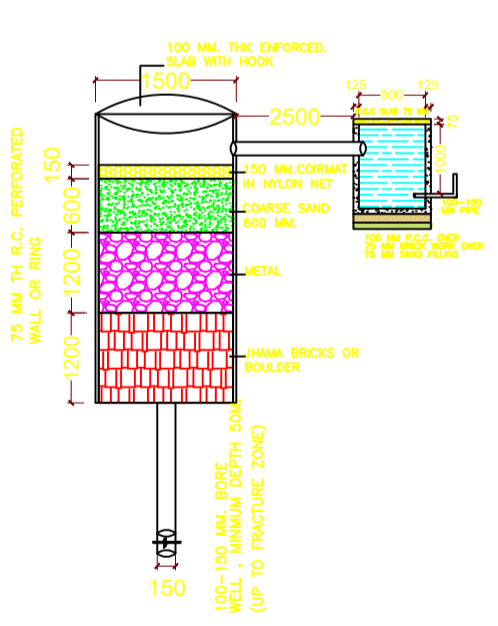

SECTION AT A-A (SCALE 1:50)

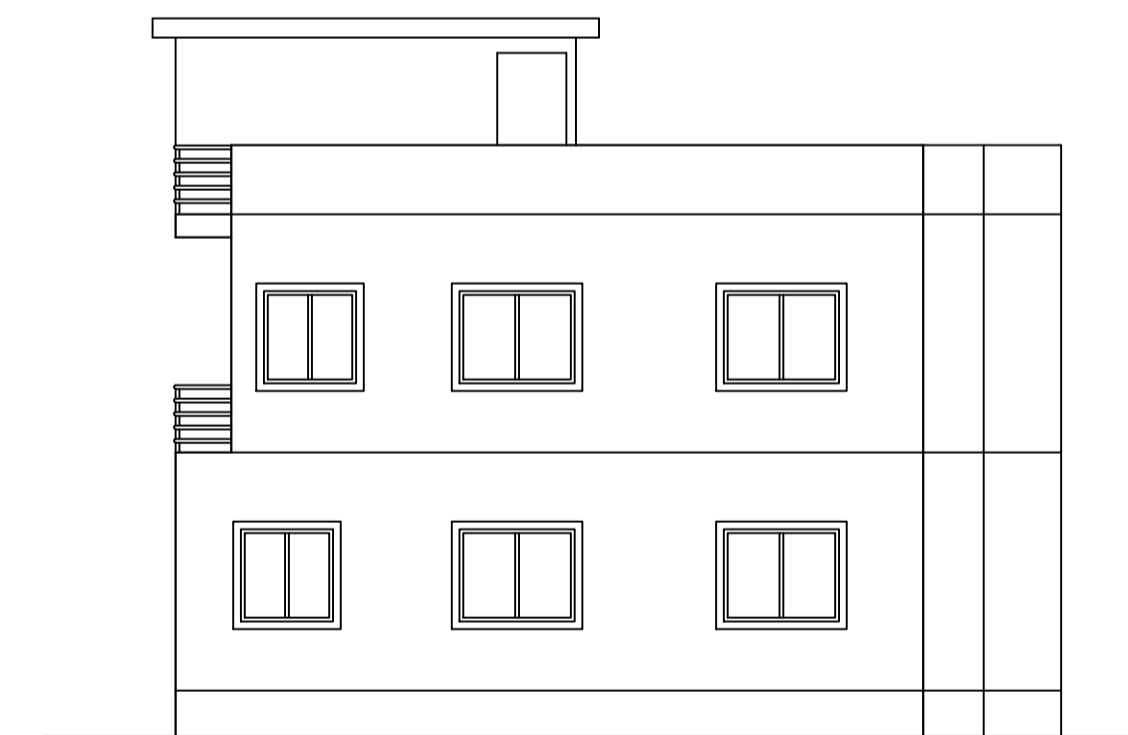

RIGHT SIDE ELEVATION Scale - 1:100

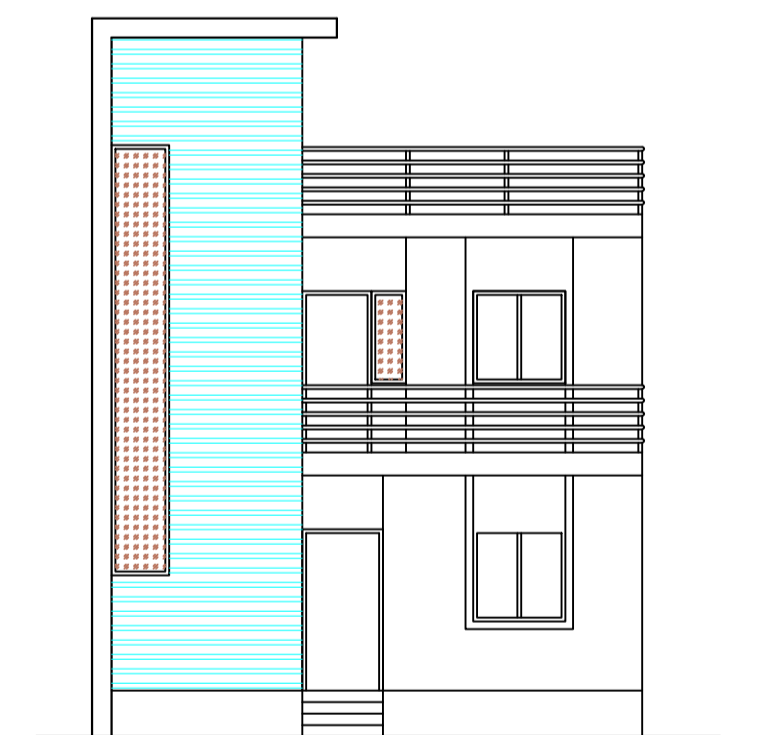

FRONT ELEVATION Scale - 1:100

SCHEDULE OF DOOR:

BUILDING NAME	NAME	LENGTH	HEIGHT	NOS
A (SMT SONY RESHMA DEVI)	D2	0.84	2.10	06
A (SMT SONY RESHMA DEVI)	D1	1.06	2.13	02
A (SMT SONY RESHMA DEVI)	D	1.07	2.13	02

SCHEDULE OF WINDOW/VENTILATION:

BUILDING NAME	NAME	LENGTH	HEIGHT	NOS
A (SMT SONY RESHMA DEVI)	V	0.62	2.70	02
A (SMT SONY RESHMA DEVI)	W1	1.20	2.70	06
A (SMT SONY RESHMA DEVI)	W	1.70	2.70	02
A (SMT SONY RESHMA DEVI)	W	2.00	2.70	02

UnitBUA Table for Building :A (SMT SONY RESHMA DEVI)

FLOOR	Name	UnitBUA Type	UnitBUA Area	Carpet Area	No. of Rooms	No. of Tenement
GROUND FLOOR PLAN	SPLIT A	FLAT	71.28	70.88	5	1
FIRST FLOOR PLAN	SPLIT A	FLAT	0.00	0.00	5	0
Total:	-	-	71.28	70.88	10	1

Building :A (SMT SONY RESHMA DEVI)

Floor Name	Total Built Up Area (Sq.mt.)	Proposed FAR Area (Sq.mt.)	Total FAR Area (Sq.mt.)	Total Consumed Additional FAR Area (Sq.mt.)	Tnmt (No.)
Ground Floor	54.53	54.53	54.53	54.53	01
First Floor	54.53	54.53	54.53	54.53	00
Terrace Floor	0.00	0.00	0.00	0.00	00
Total:	109.06	109.06	109.06	109.06	01
Total Number of Same Buildings	1				
Total:	109.06	109.06	109.06	109.06	01

LTP NAME AND SIGNATURE	STRUCTURAL ENG'S NAME AND SIGNATURE	BUILDER NAME AND SIGNATURE	DIGITAL SIGNATURE
ASHWINI KUMAR SAHU LNP/ENG/0005/2017			