

SCHEDULE OF DOOR:

BUILDING NAME	NAME	LENGTH	HEIGHT	NOS
A (SRI SHIV PRASAD ROY MRS NEELU DEVI)	D2	0.75	2.13	04
A (SRI SHIV PRASAD ROY MRS NEELU DEVI)	D1	0.90	2.13	10
A (SRI SHIV PRASAD ROY MRS NEELU DEVI)	D	0.95	2.13	04

SCHEDULE OF WINDOW/VENTILATION:

BUILDING NAME	NAME	LENGTH	HEIGHT	NOS
A (SRI SHIV PRASAD ROY MRS NEELU DEVI)	V	0.60	1.20	04
A (SRI SHIV PRASAD ROY MRS NEELU DEVI)	W1	1.00	2.70	02
A (SRI SHIV PRASAD ROY MRS NEELU DEVI)	W	1.20	2.70	22

FAR & Tenement Details (Table 4c-1)

Building	No. of Same Bldg	Total Built Up Area (Sq.mt.)	Proposed FAR Area (Sq.mt.) Resi.	Total FAR Area (Sq.mt.)	Total Consumed Additional FAR Area (Sq.mt.)	Tnmt (No.)
A (SRI SHIV PRASAD ROY MRS NEELU DEVI)	1	239.80	239.80	239.80	239.80	01
Grand Total :	1	239.80	239.80	239.80	239.80	01

Buildingwise Floor FAR Details

Floor Name	Building Name		Total	
	A (SRI SHIV PRASAD ROY MRS NEELU DEVI)	Proposed FAR Area (Sq.mt.)	Total Proposed Built Up Area (Sq.mt.)	Total FAR Area (Sq.mt.)
Ground Floor	119.90	119.90	119.90	119.90
First Floor	119.90	119.90	119.90	119.90
Terrace Floor	0.00	0.00	0.00	0.00
Total :	239.80	239.80	239.80	239.80

Building :A (SRI SHIV PRASAD ROY MRS NEELU DEVI)

Floor Name	Total Built Up Area (Sq.mt.)	Proposed FAR Area (Sq.mt.) Resi.	Total FAR Area (Sq.mt.)	Total Consumed Additional FAR Area (Sq.mt.)	Tnmt (No.)
Ground Floor	119.90	119.90	119.90	119.90	01
First Floor	119.90	119.90	119.90	119.90	00
Terrace Floor	0.00	0.00	0.00	0.00	00
Total :	239.80	239.80	239.80	239.80	01
Total Number of Same Buildings	1				
Total :	239.80	239.80	239.80	239.80	01

COLOR INDEX

PLOT BOUNDARY	Black
ABUTTING ROAD	Green
PROPOSED CONSTRUCTION	Red
COMMON PLOT	Yellow
ROAD WIDENING AREA	Blue
EXISTING (To be retained)	Orange
EXISTING (To be demolished)	Light Blue

Building USE/SUBUSE Details

Building Name	Building Use	Building SubUse	Building Structure
A (SRI SHIV PRASAD ROY MRS NEELU DEVI)	Residential	Bungalow/ Dwelling / Non Apartment	Non-Highrise

UnitBUA Table for Building :A (SRI SHIV PRASAD ROY MRS NEELU DEVI)

FLOOR	Name	UnitBUA Type	UnitBUA Area	Carpet Area	No. of Rooms	No. of Tenement
GROUND FLOOR PLAN	SPLIT A	FLAT	193.94	193.45	9	1
FIRST FLOOR PLAN	SPLIT A	FLAT	0.00	0.00	9	0
Total:	-	-	193.94	193.45	18	1

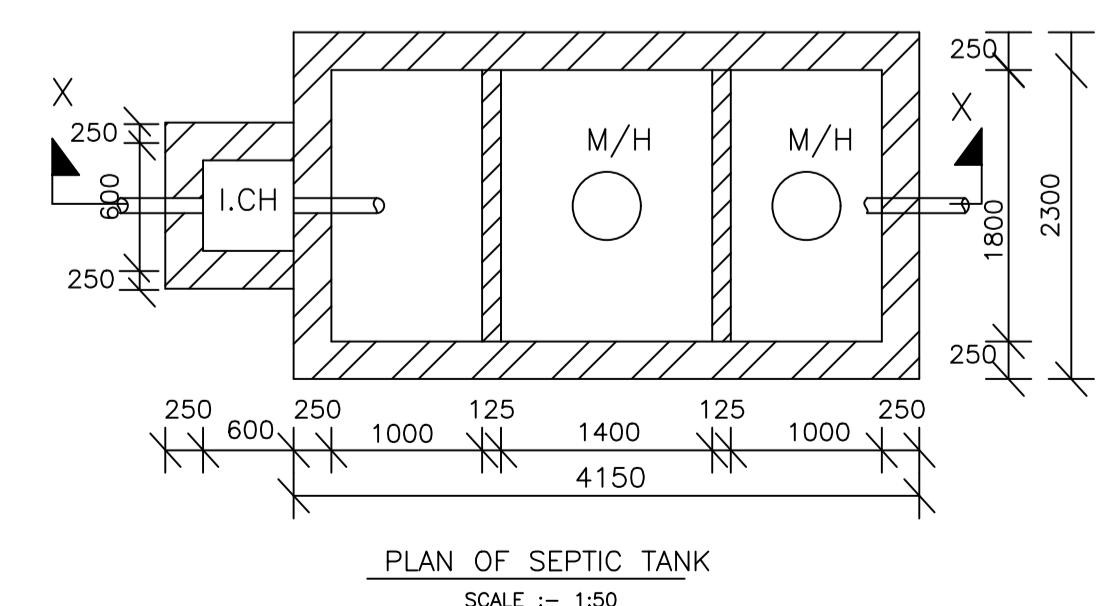
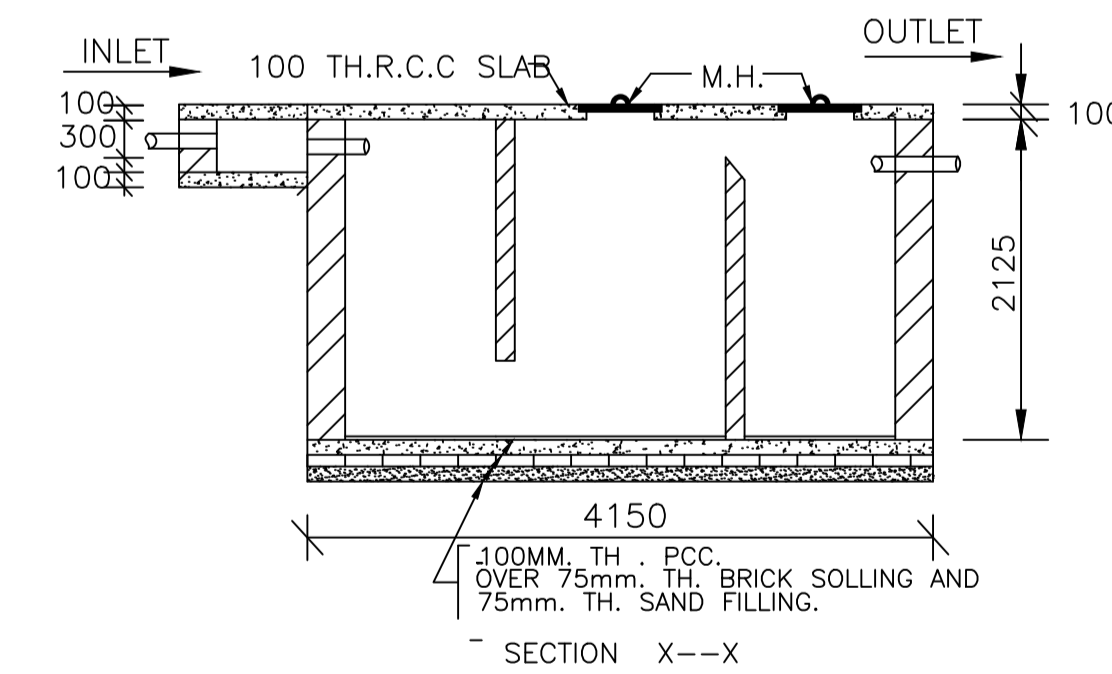
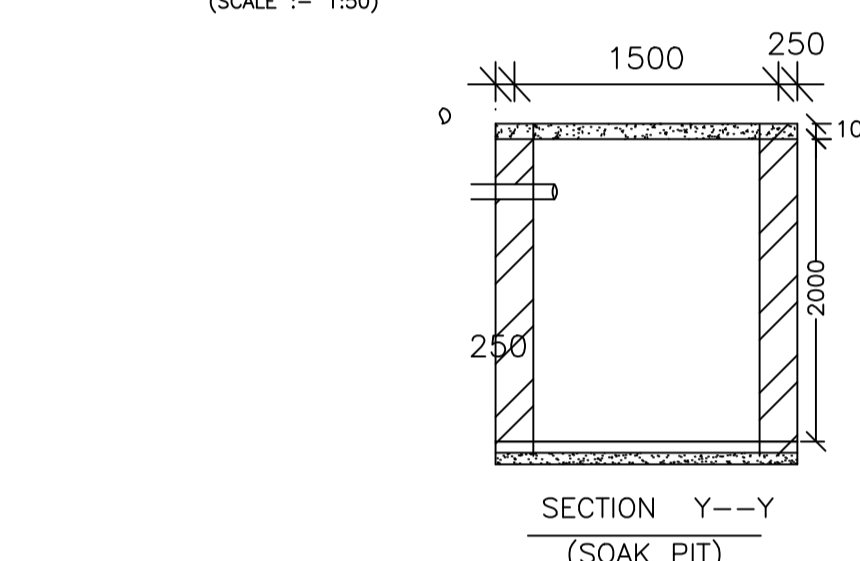
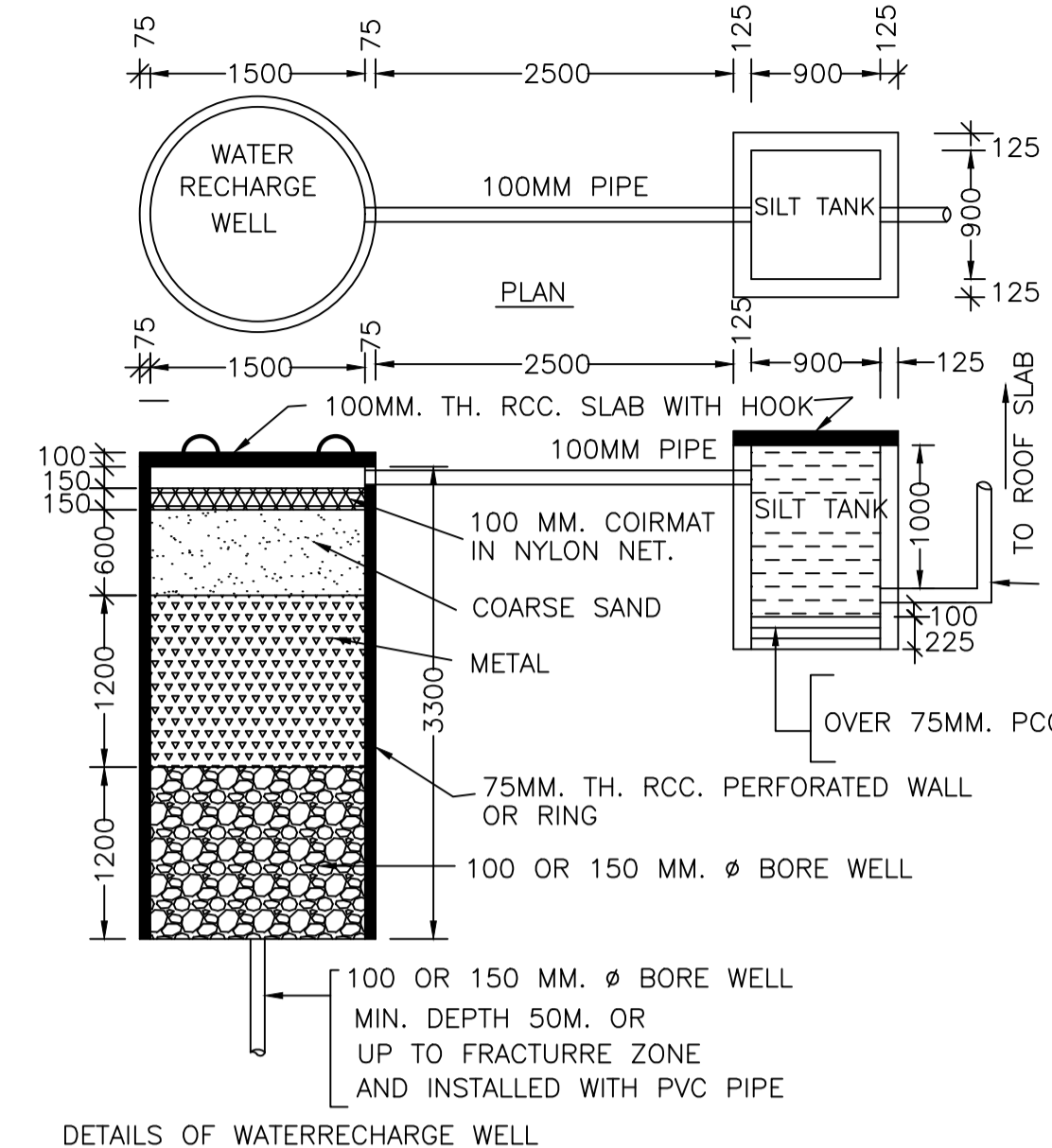

Proposal Basic Information

Proposal File No.	LNP/BP/0006/W22/2019
Owner Name	SRI SHIV PRASAD ROY & MRS NEELU DEVI
Khata No	85
Plot No	1148
Village Name	Lohardaga
Use	Residential
SubUse	Bungalow/ Dwelling / Non Apartment

AREA STATEMENT LOHARDAGA NAGAR PARISHAD

VERSION NO: 1.0.35  
VERSION DATE: 13/03/2019

PROJECT DETAIL:  
Region: JHARKHAND URBAN LOCAL BODIES  
District: LOHARDAGA  
Authority: LOHARDAGA NAGAR PARISHAD  
Inward No: LNP/BP/0006/W22/2019  
Application Type: General Proposal  
Project Type: Building Permission  
Nature of Development: New  
Location of Development Area: Old Area

Plot Use: Residential  
Plot/SubPlot No: 1148  
Plot/Nearby/Religious/Structure: NA  
North: -  
South: -  
East: -  
West: -

AREA DETAILS:	SQ.MT.
AREA OF PLOT (Minimum)	224.84
Deduction for NetPlot Area	
Surrender Free of Cost	21.90
Total	21.90
NET AREA OF PLOT(Gross Plot Area - Deduction from Gross Plot area)	202.94
Deduction for Balance Plot Area(from Gross Plot Area)	
Surrender Free of Cost	21.90
Common Plot	26.38
Total	48.28
BALANCE AREA OF PLOT(Net Plot Area - Recreational/Amenity space)	176.56
PLOT AREA FOR COVERAGE(Net Plot Area)	202.94
Plot Area for FAR (Net Plot Area + Road/Widening Area)	224.84
COVERAGE CHECK	
Permissible Coverage area ( 70.00 % )	142.06
Proposed Coverage Area ( 59.08 % )	119.90
Total Prop. Coverage Area ( 59.08 % )	119.90
Balance coverage area ( 10.92 % )	22.16
FAR CHECK	
Perm. FAR Area ( 1.50 )	337.26
Total Perm. FAR area	337.26
Residential FAR	239.80
Proposed FAR Area	239.80
Total Proposed FAR Area	239.80
Consumed FAR (Factor)	1.07
Balance FAR Area	97.46
BUILT UP AREA CHECK	
Total Proposed BuiltUp Area	239.80
ARCHITECT (Regd)	SUNIL KUMAR
ENGINEER (Regd)	
SUPERVISOR (Regd)	
OWNER (Regd)	SRI SHIV PRASAD ROY & MRS NEELU DEVI
DEVELOPMENT AUTHORITY	LOCAL BODY

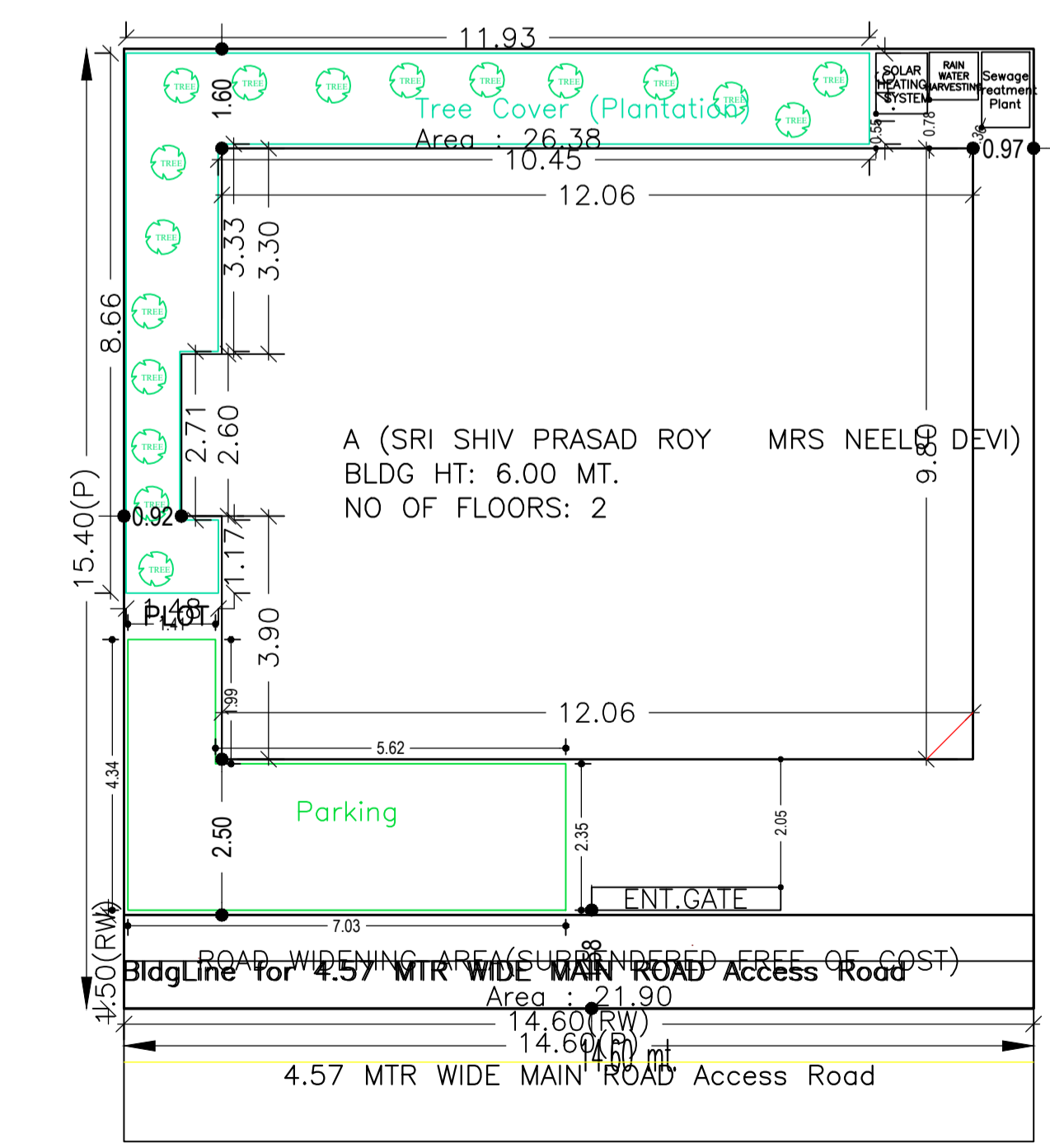
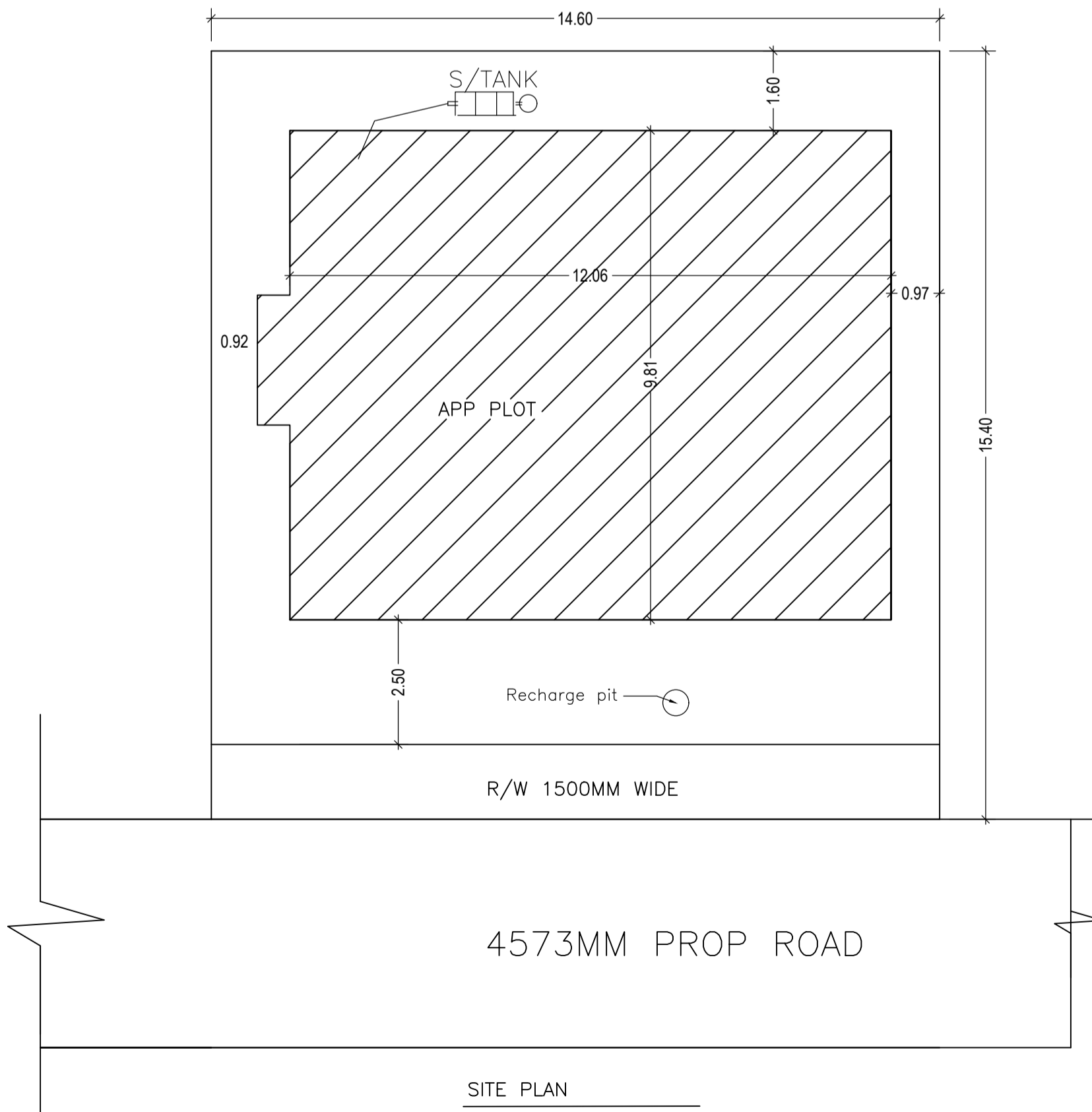

15.40 mt.

LTP NAME AND SIGNATURE	STRUCTURAL ENG'S NAME AND SIGNATURE	BUILDER NAME AND SIGNATURE	DIGITAL SIGNATURE
SUNIL KUMAR LNP/ENG/0004/2017			

Proposal Basic Information	
Proposal File No.	LNP/BP/0006/W22/2019
Owner Name	SRI SHIV PRASAD ROY & MRS NEELU DEVI
Khata No	85
Plot No	1148
Village Name	Lohardaga
Use	Residential
SubUse	Bungalow/ Dwelling / Non Apartment

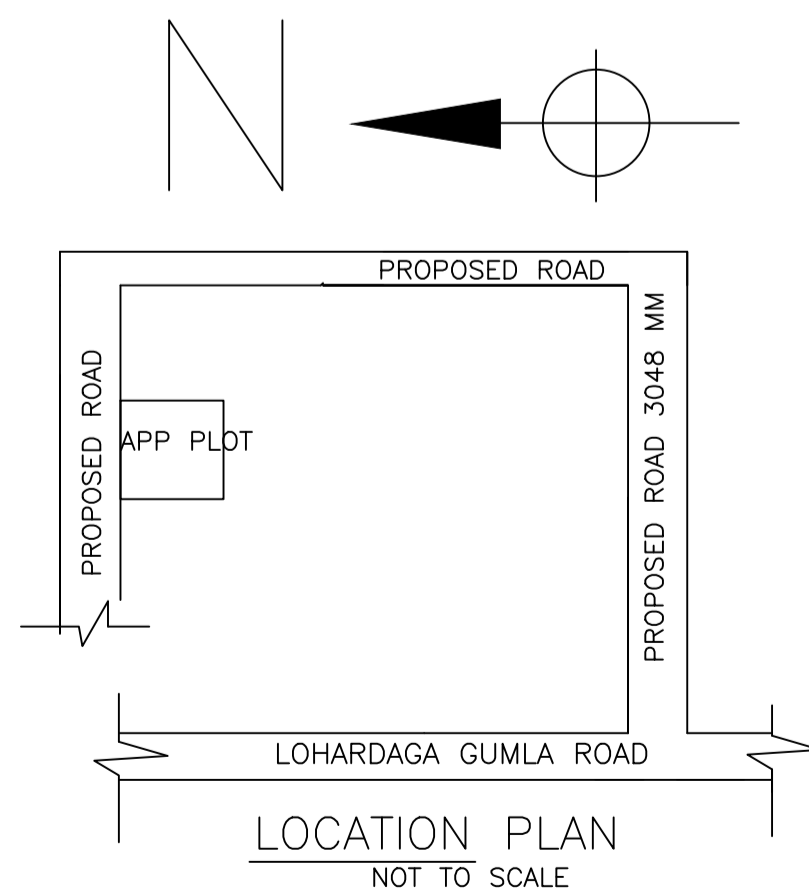
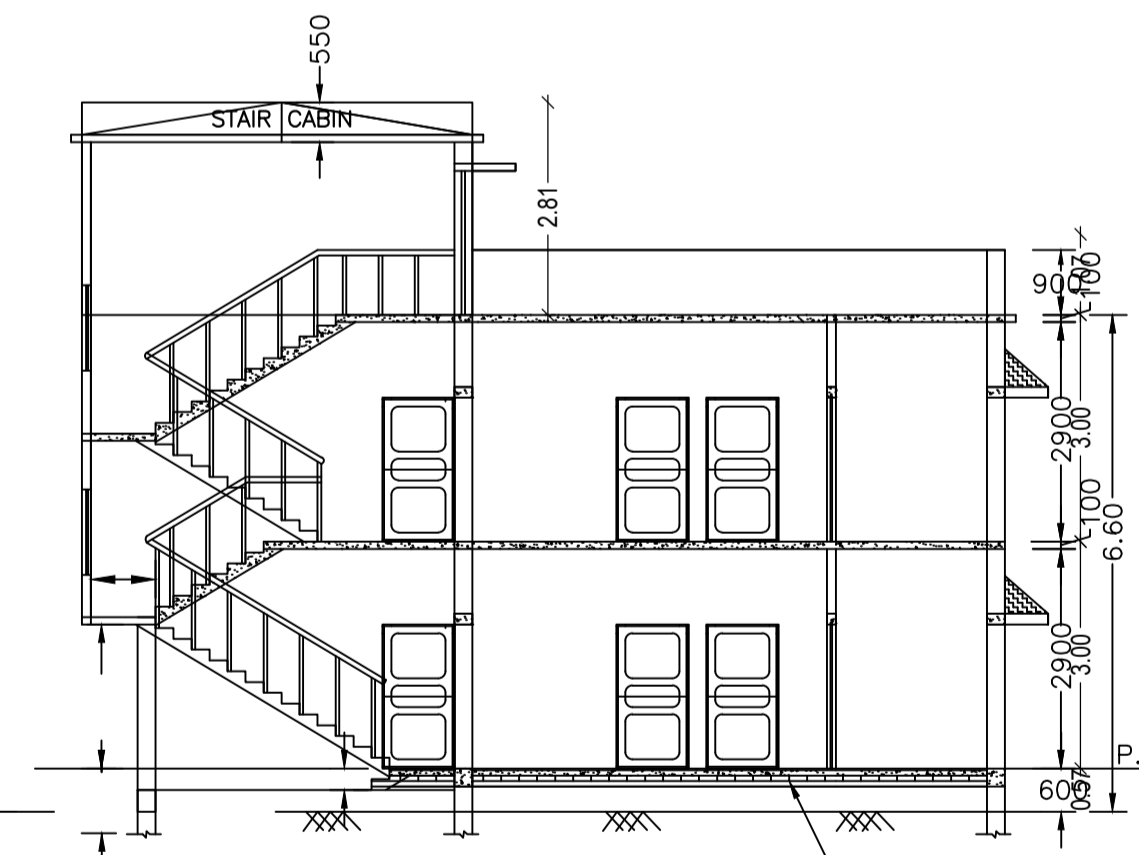
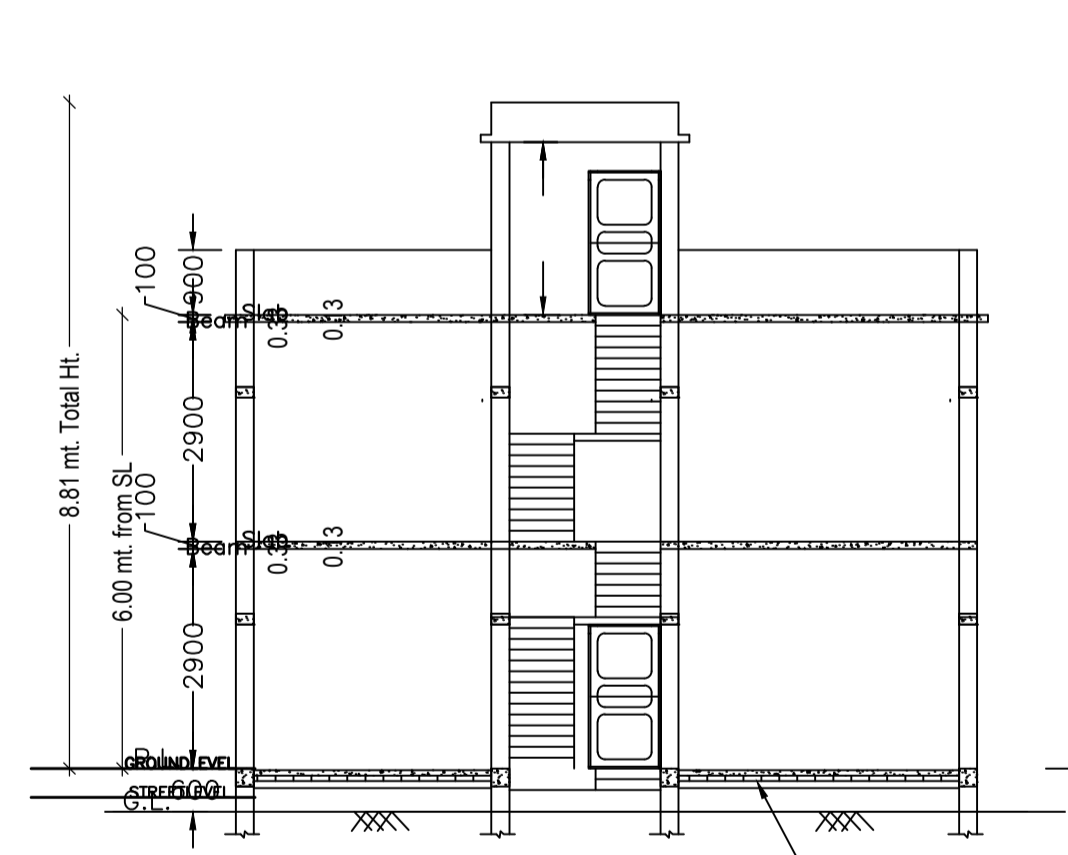
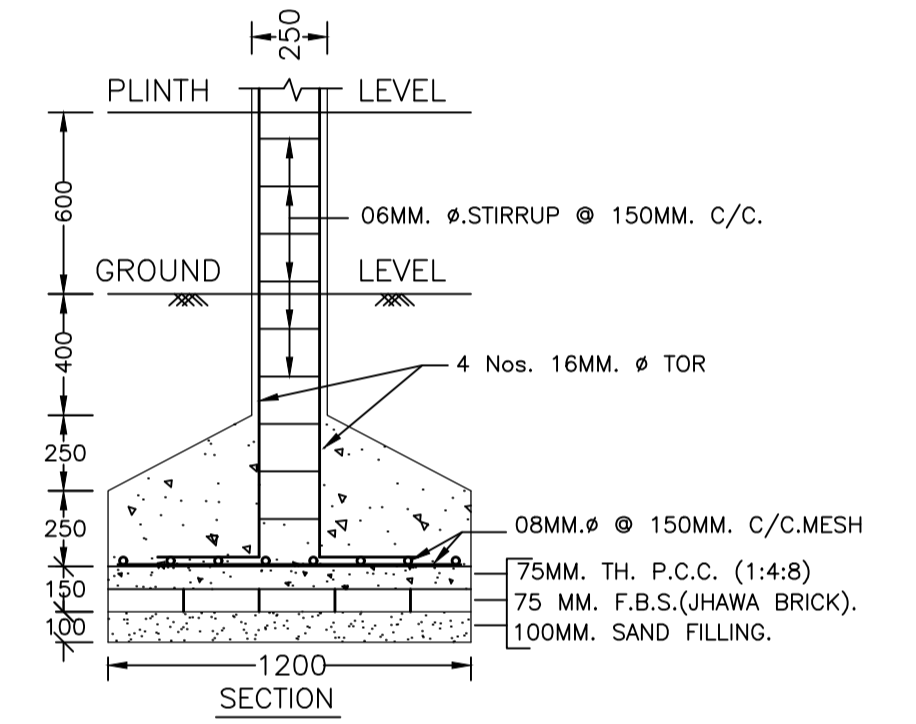
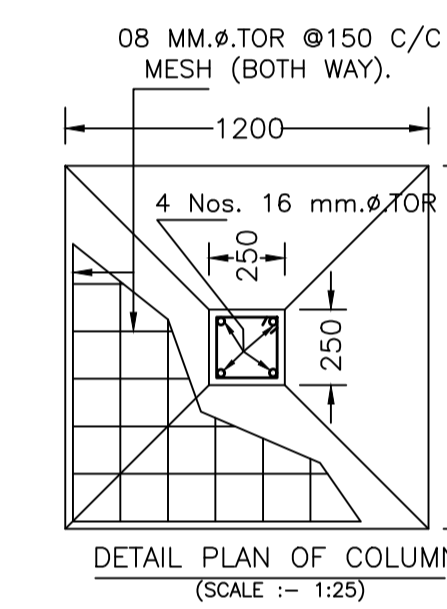
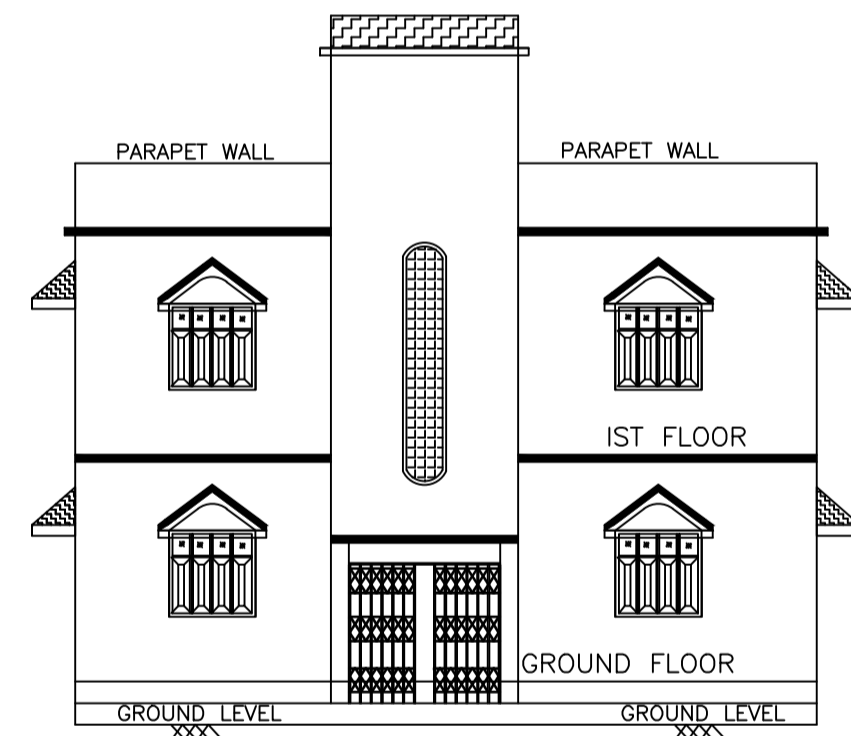
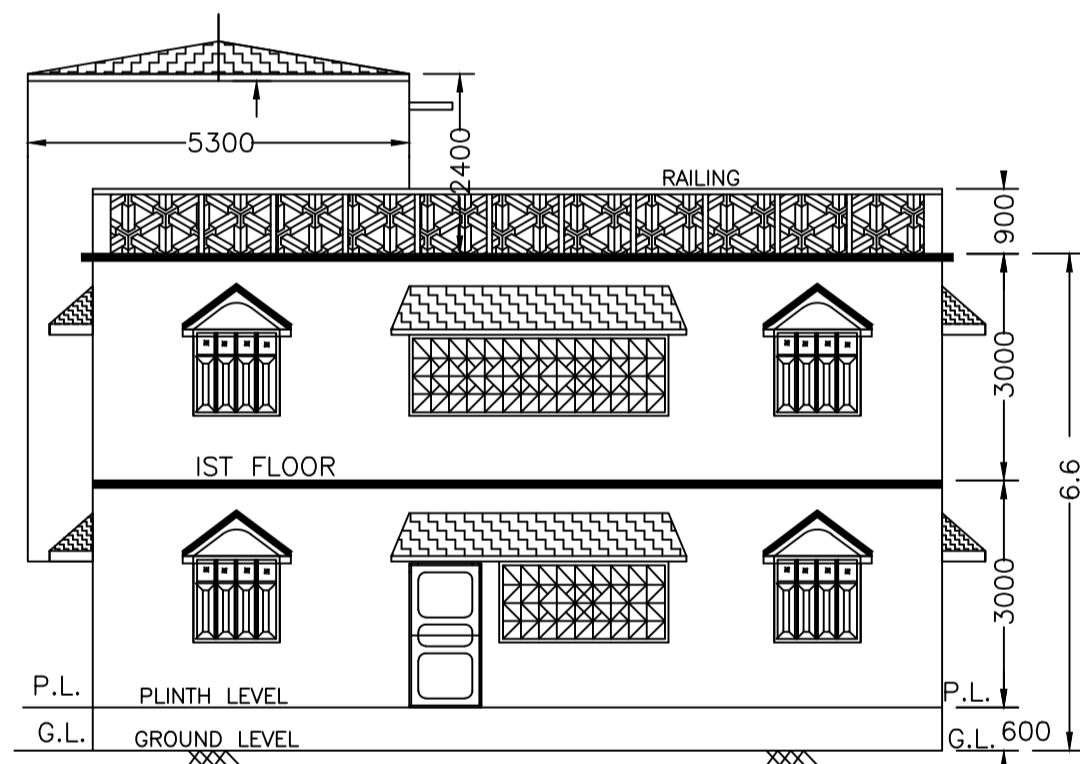
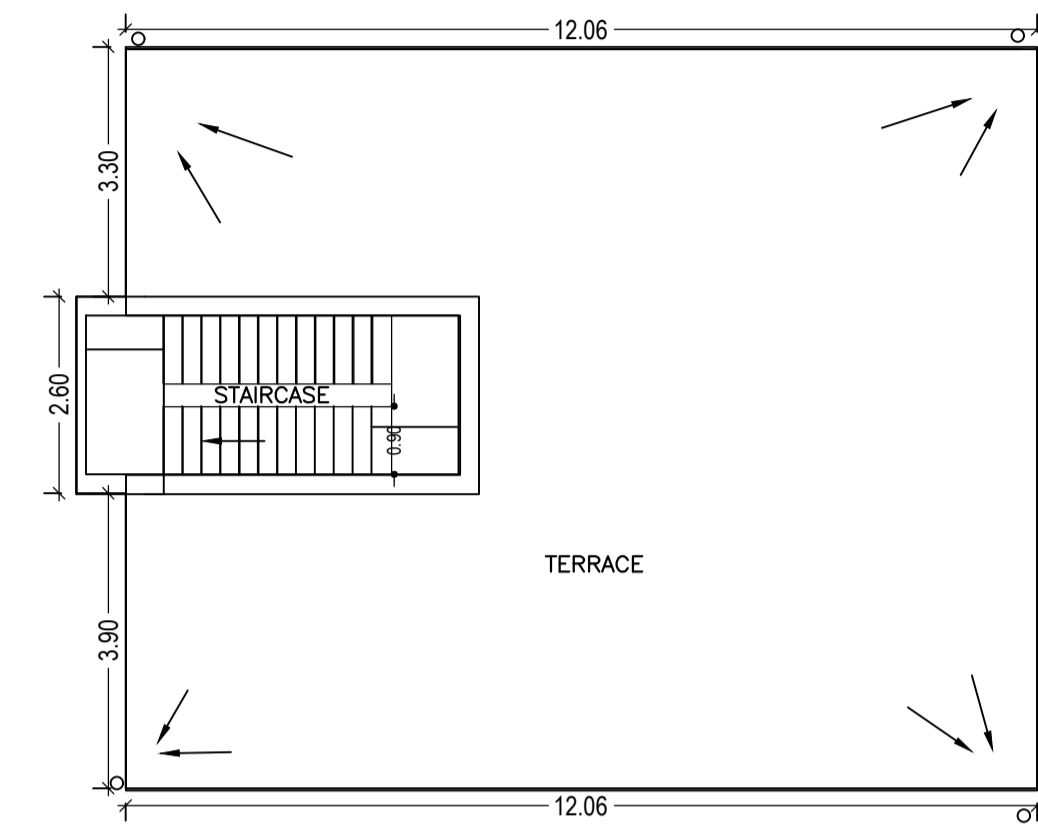
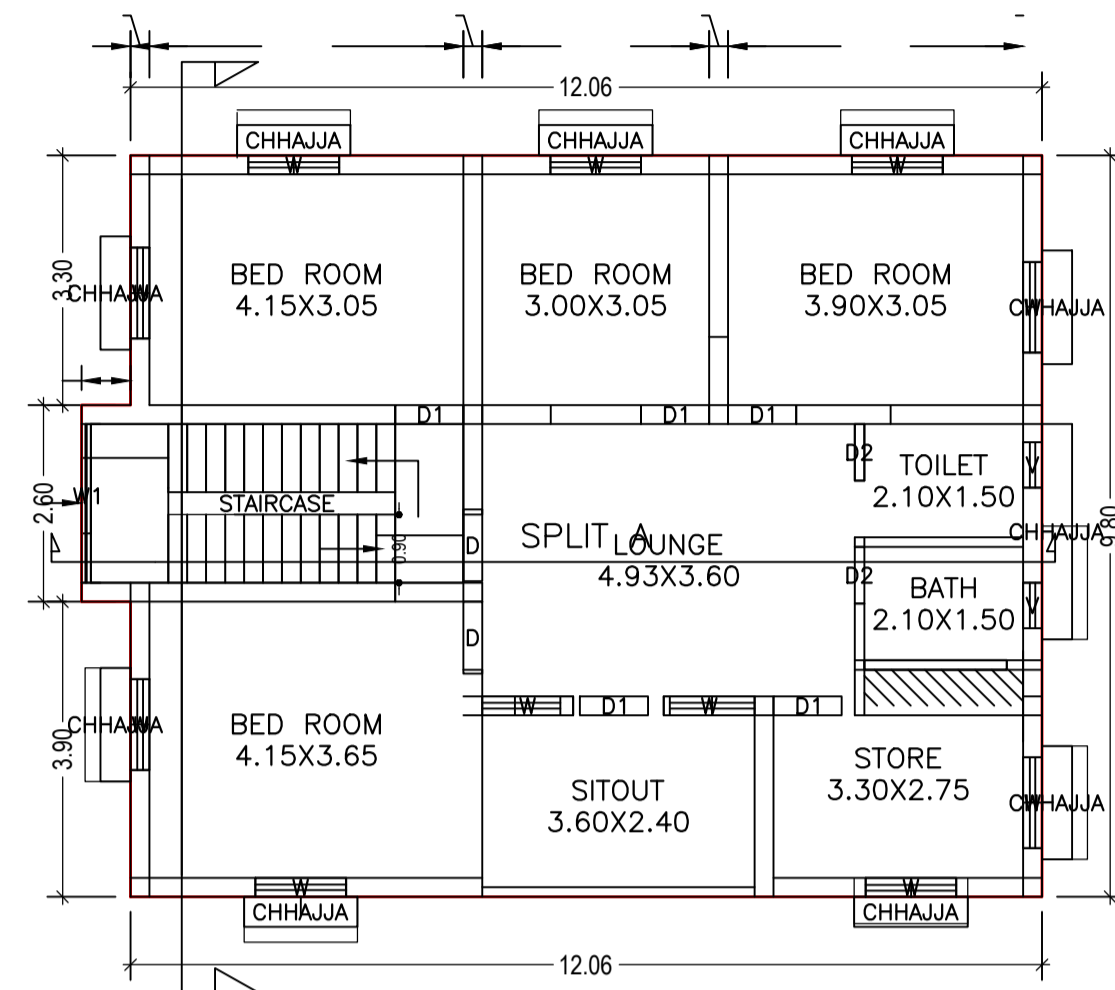
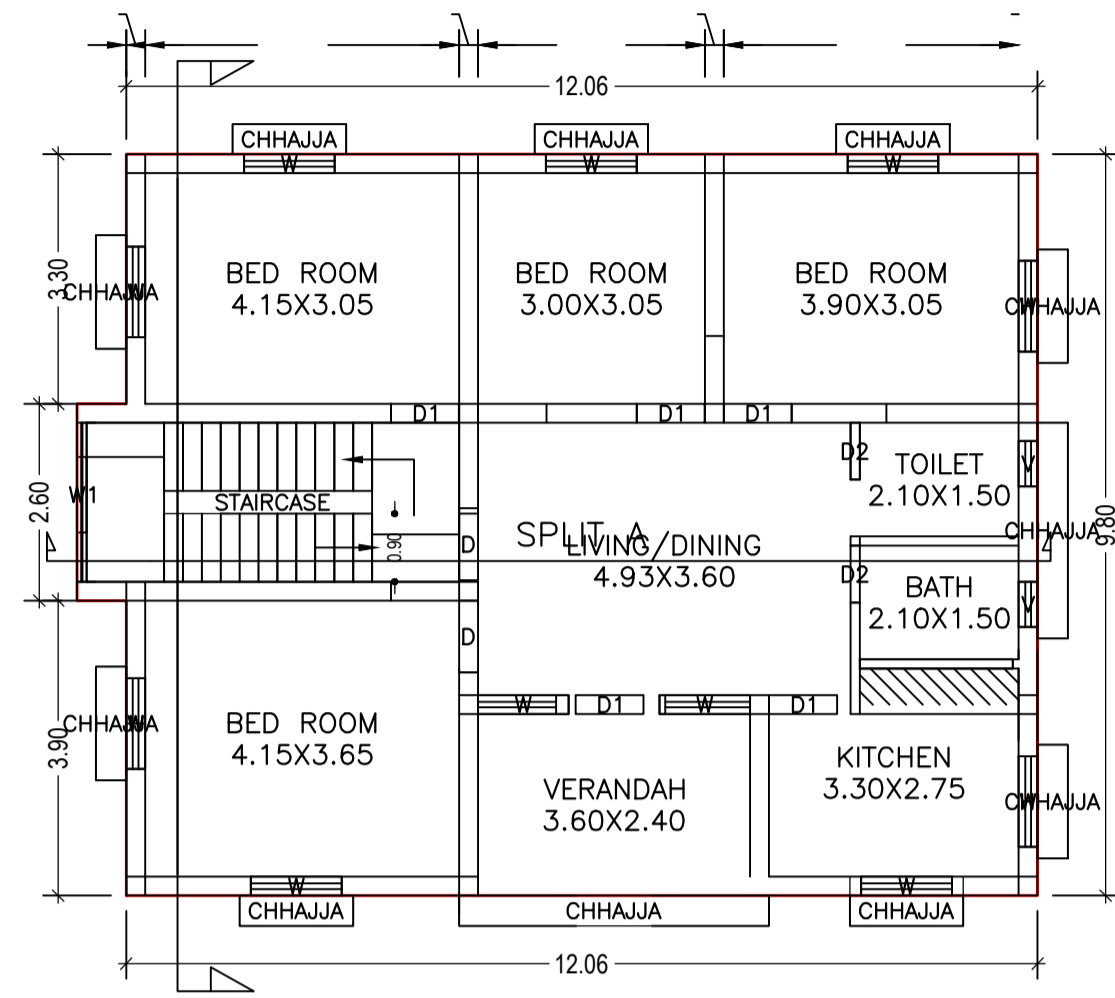

LTP NAME AND SIGNATURE	STRUCTURAL ENG'S NAME AND SIGNATURE	BUILDER NAME AND SIGNATURE	DIGITAL SIGNATURE
SUNIL KUMAR LNP/ENG/0004/2017			