

Project Title :SUMRAREN KERKETTA

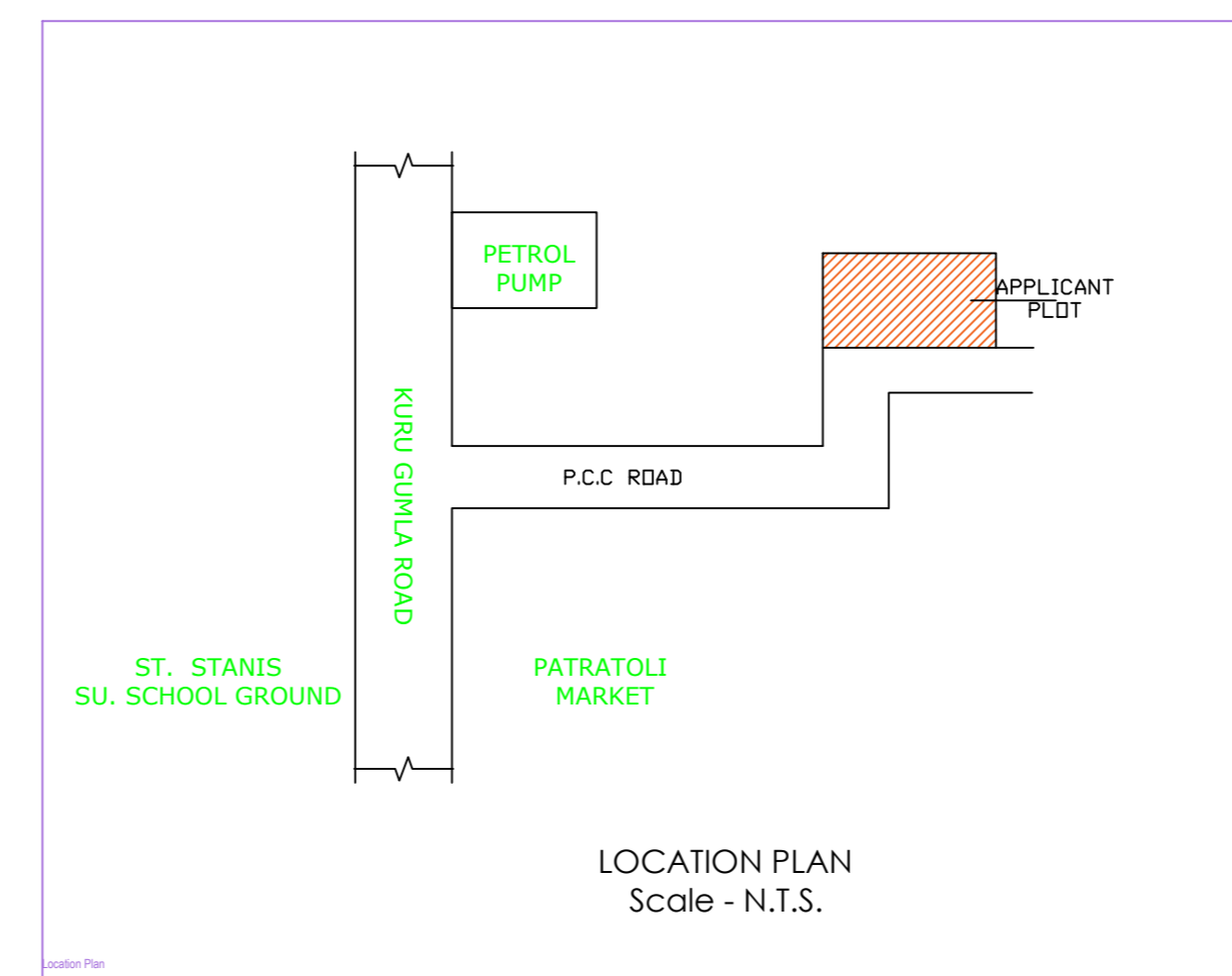
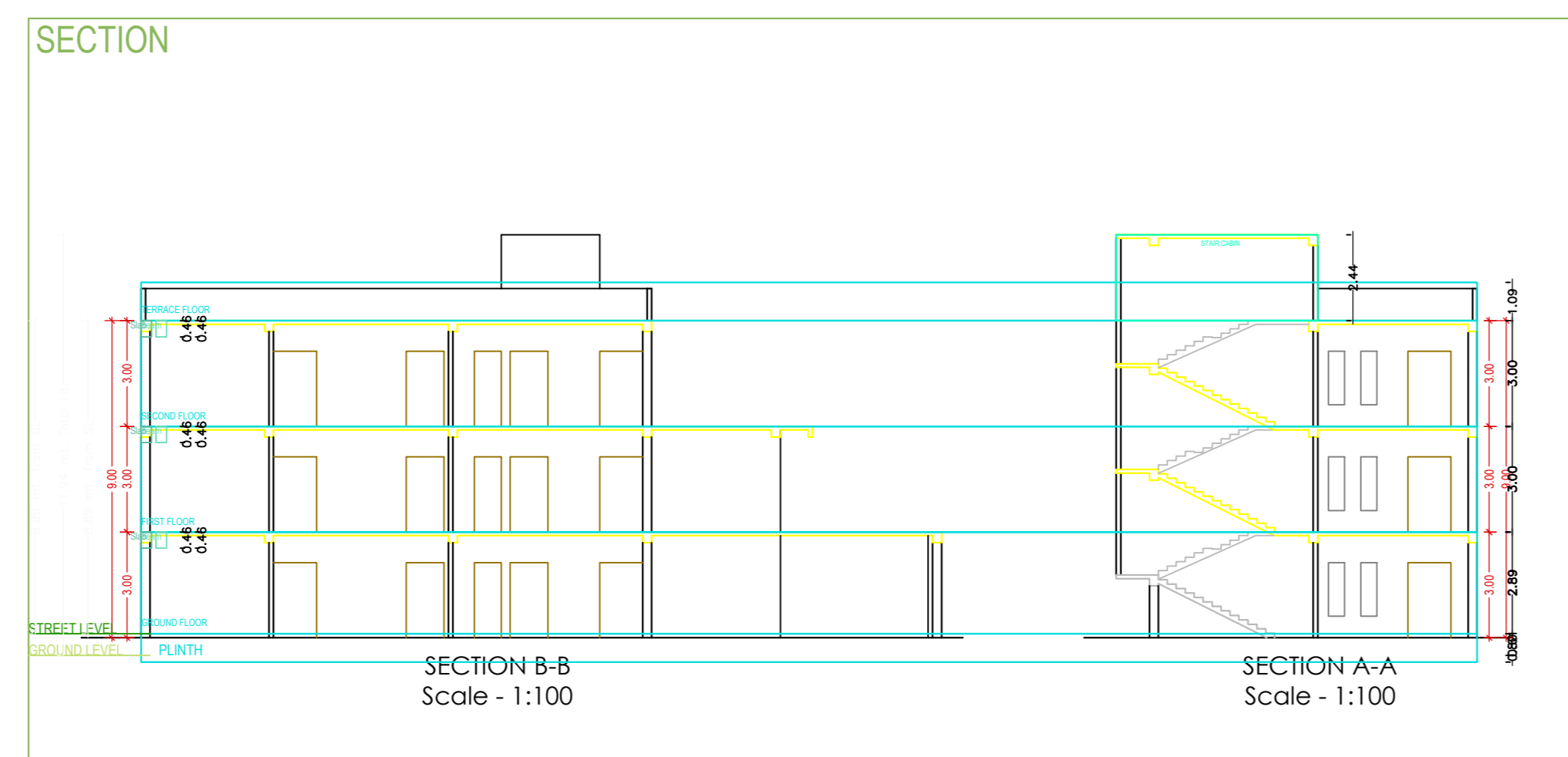
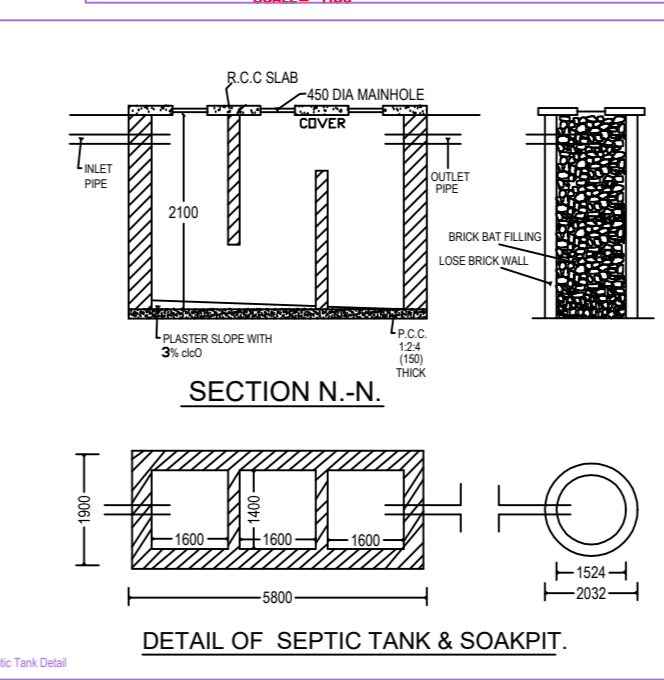
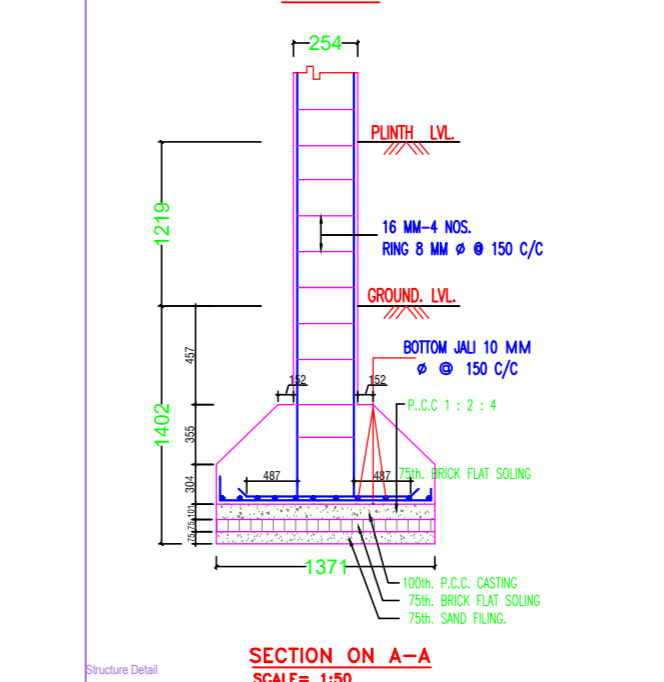
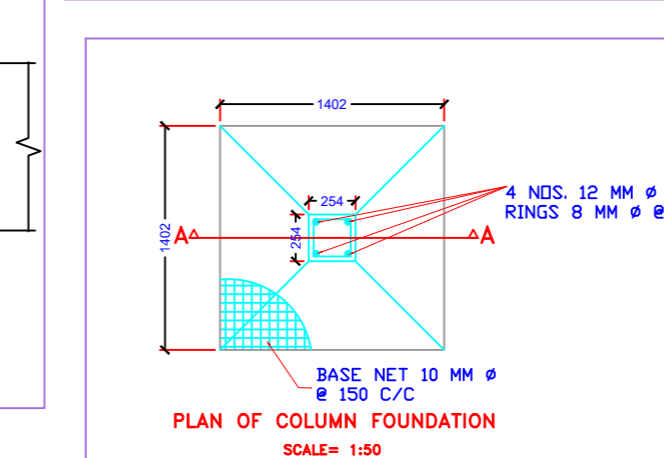
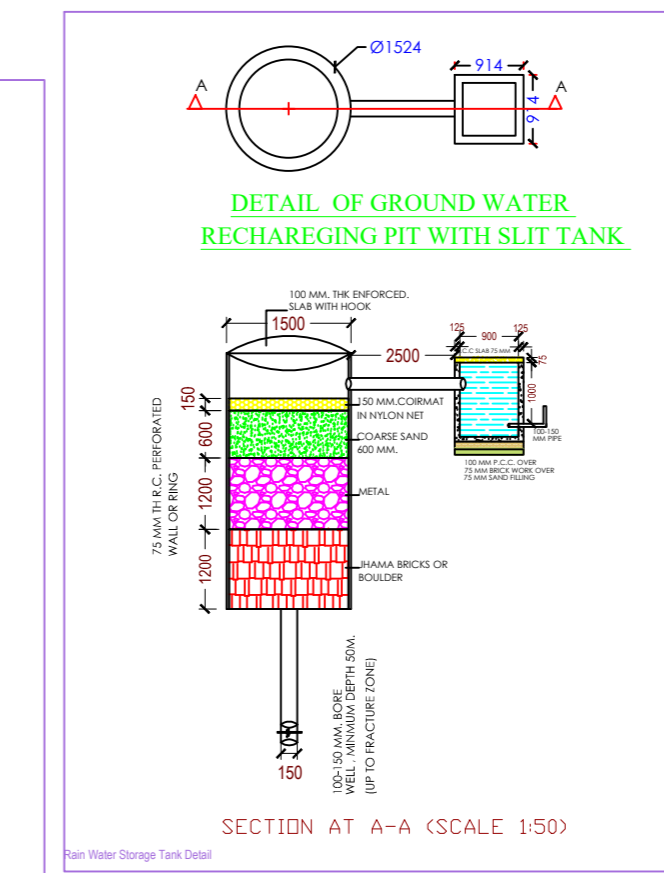
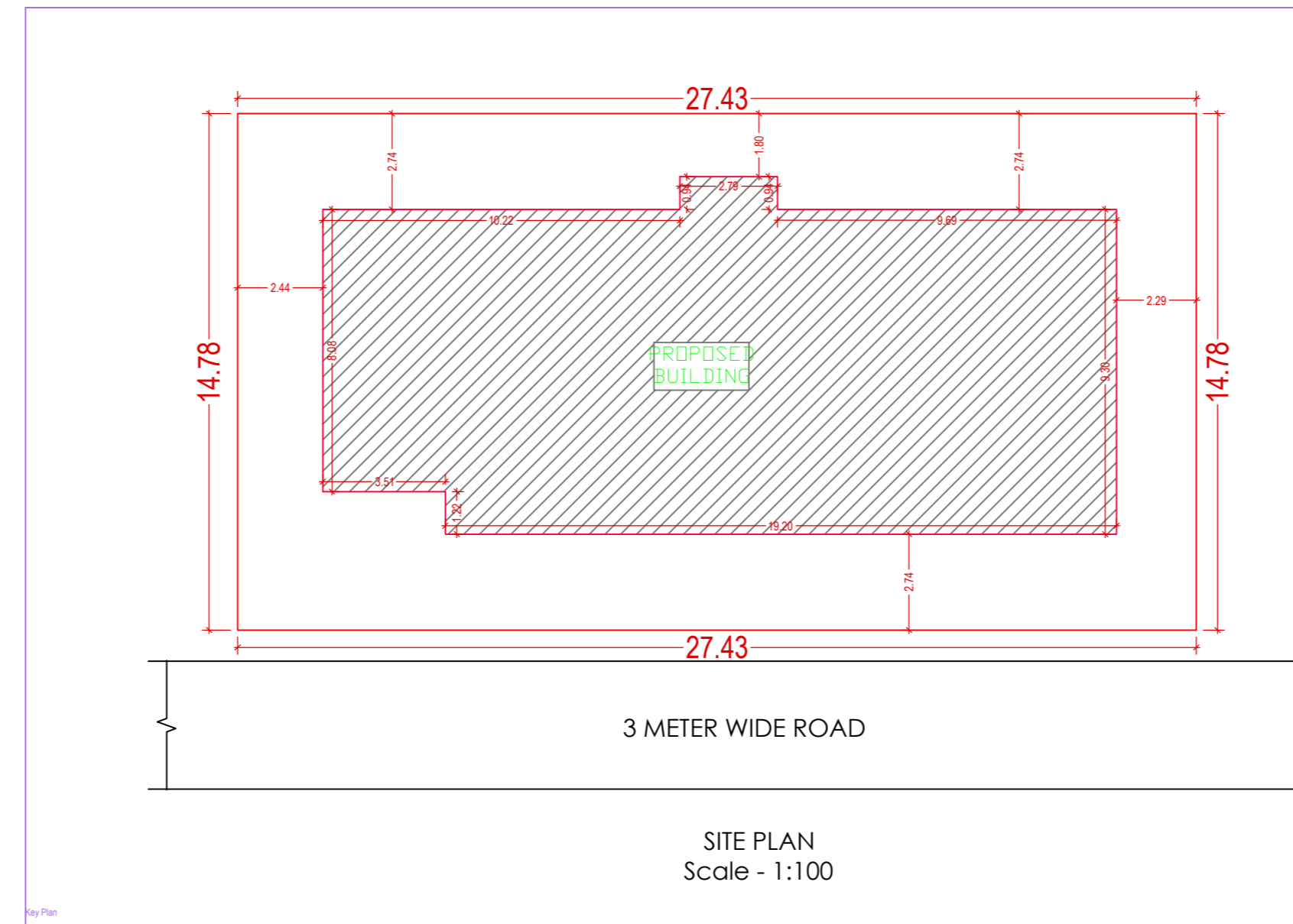

General notes

1. ALL DIMENSION ARE IN MILLIMETRES UNLESS OTHERWISE STATED.
2. NO DIMENSION IS TO BE SCALED OF THE DRAWING.
3. DRAWINGS TO BE READ IN CONJUNCTION WITH ALL RELEVANT DRAWINGS & SPECIFICATIONS.
4. REFER WRITTEN DIMENSIONS ONLY.
5. DOORS AND WINDOW FRAME NOT TO BE FIXED ALONG WITH BRICK WORK.
6. INTERNAL PLASTER SHOULD BE 12MM THICK AND EXTERNAL PLASTER IS 25MM THICK.
7. FOUNDATION DEPTH UPTO GOOD SOIL.
8. CEMENT MORTAR OF MIX (1:4) FOR ENTIRE STRUCTURE AND PLASTER WORK.
9. SEPTIC TANK WILL BE FLUSHING SYSTEM.
10. ALL REINFORCEMENT SHALL BE OF TOR STEEL OF GRADE FY 415.
11. GRADE OF CONCRETE SHALL BE M-20

TYPE	WIDTH	HEIGHT	SILL LVL	DISCRPTION
D	1050	2100	NILL	SINGLE SHUTTER FLUSH DOOR
D1	900	2100	NILL	**
W	1200	1200	900	4 LEAF GLAZED WIND
W1	900	1200	900	**
V	600	600	2400	VENTILATOR

Schedule of area

PLOT AREA AT DEED - 405.52 SQ.M.
 AREA OF GROUND FLOOR - 209.45 SQ.M.
 AREA OF FIRST FLOOR - 180.78 SQ.M.
 AREA OF SECOND FLOOR - 155.37 SQ.M.
 TOTAL COVERED AREA - 545.06 SQ.M.
 % OF COVERED AREA - 51.64%
 TOTAL F.A.R. ACHIEVED - 1.34

owner
 PROPS RESIDENTIAL BUILDING PLAN OF SUMRAREN KERKETTA W/O LATE JAGDISH KERKETTA
 R/S, PLOT NO. - 1605/1541, KHATA NO. -13
 THANA NO. -212, WARD NO. -05,
 AREA -10 DECIMALS,
 VILLAGE - KAIMO - LOHARDAGA
 DIST - LOHARDAGA - 835302,
 STATE - JHARKHAND

ISSUE ONLY FOR CLIENT

SCALE: 1 : 100 DATE: SHEET NO. 01 OF 01

CLIENT: ENGINEER / ARCHITECT

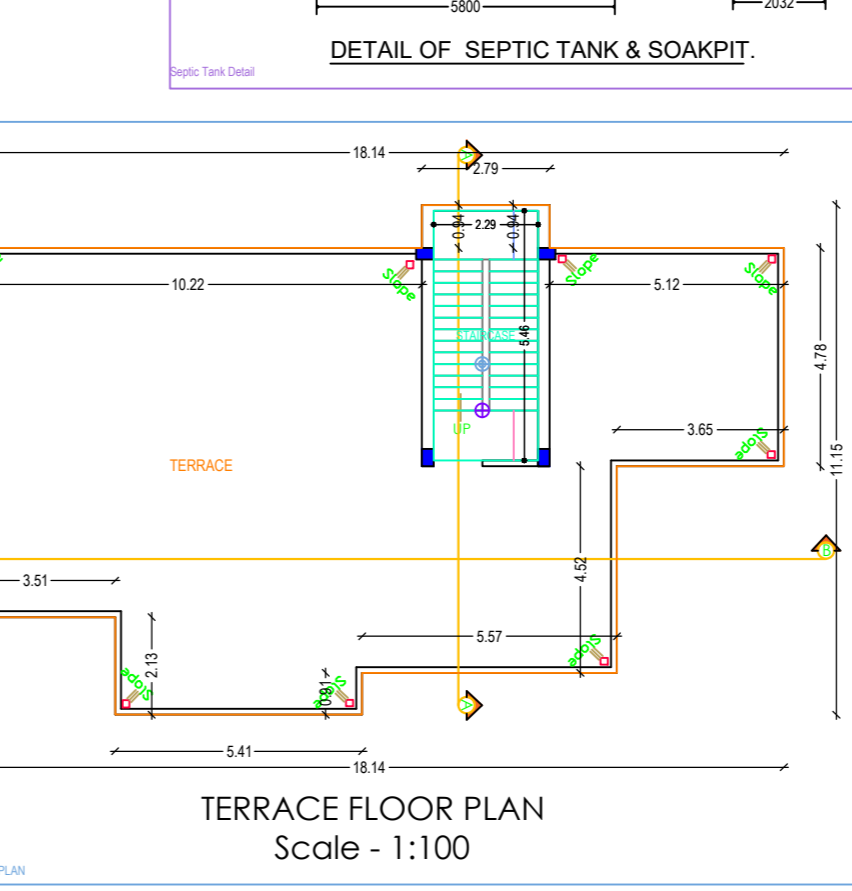
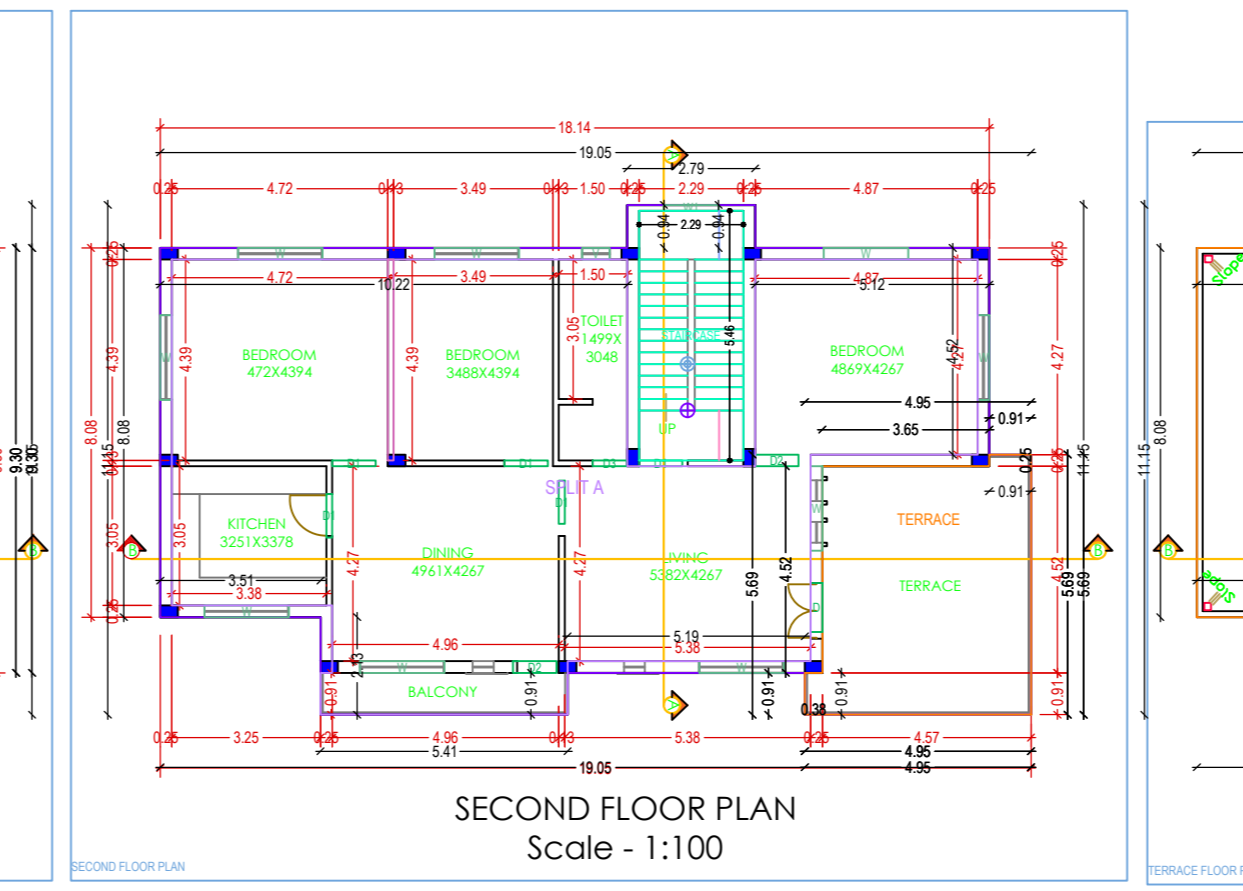
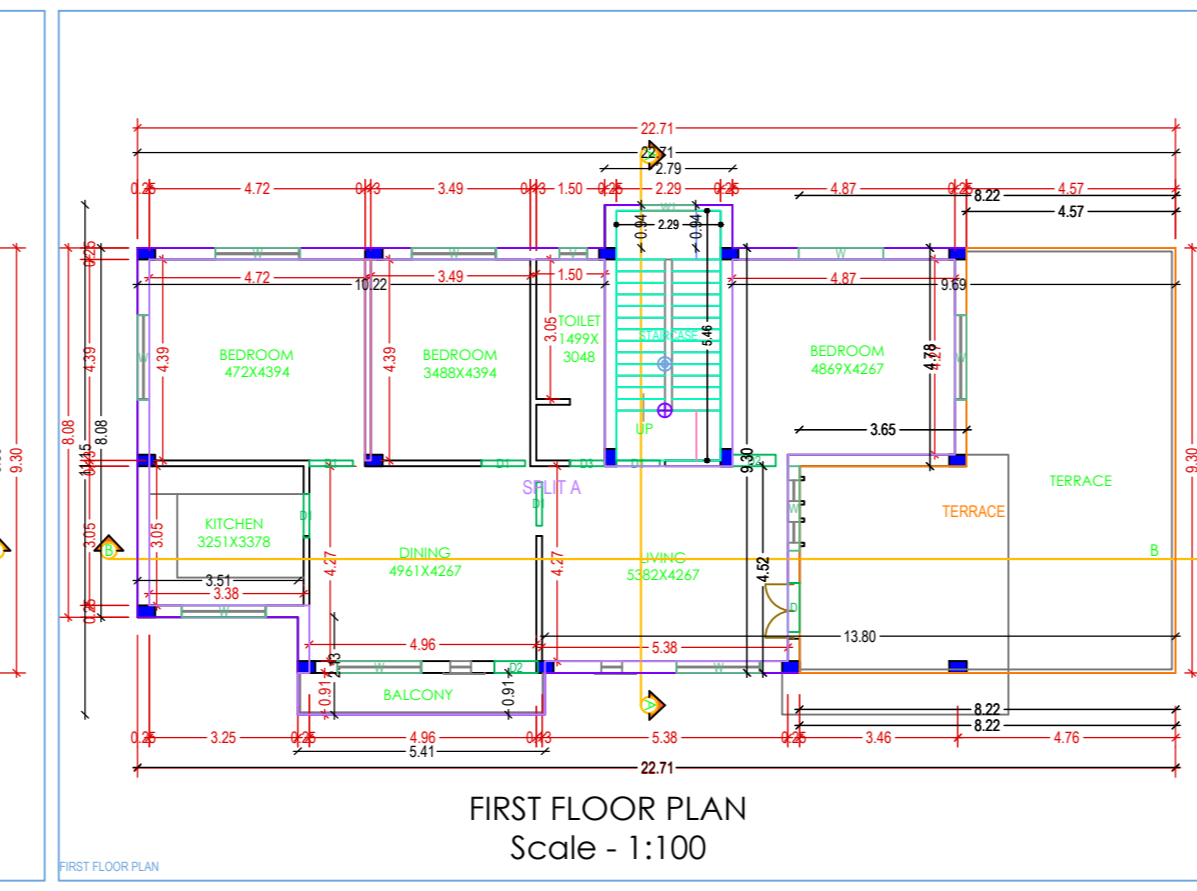
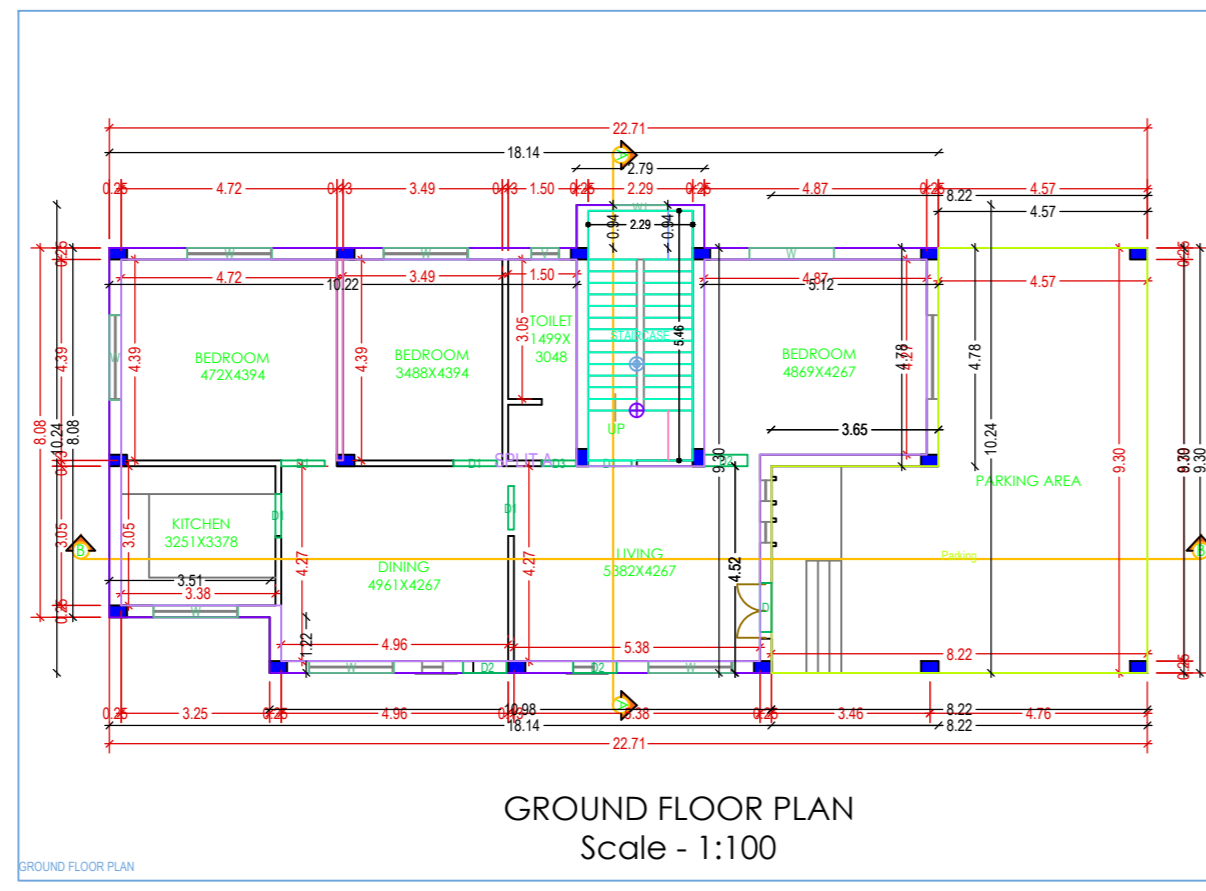
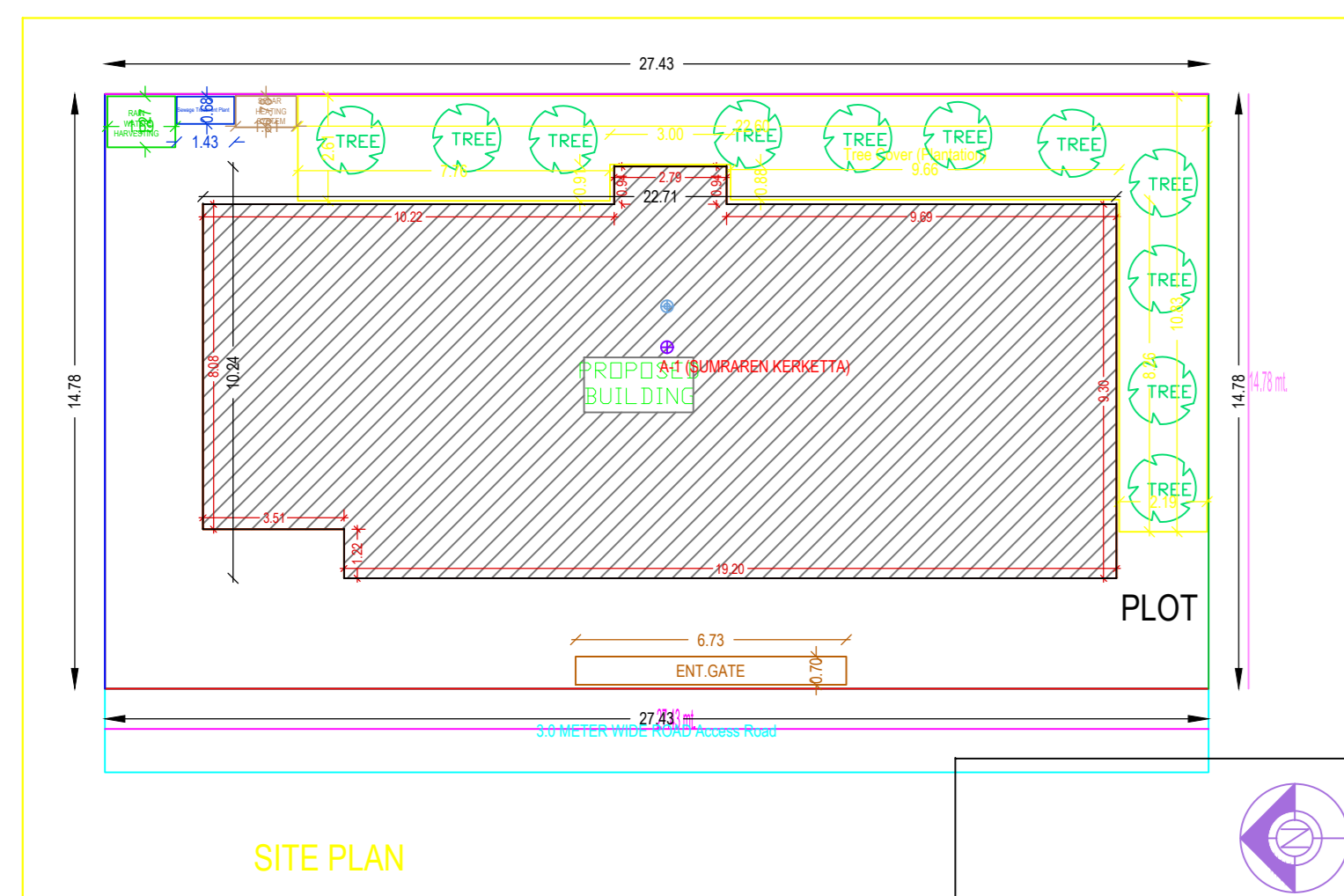

Building A (SUMRAREN KERKETTA)

Room Name	Floor	Area (Sq. Ft.)	Volume (Cu. Ft.)	Permitted Area (Sq. Ft.)	Permitted Volume (Cu. Ft.)	Permitted Height (Feet)	Permitted No. of Floors
Ground Floor	01	209.45	1807.8	209.45	1807.8	8.65	01
First Floor	02	180.78	1553.7	180.78	1553.7	8.65	02
Second Floor	03	155.37	1338.1	155.37	1338.1	8.65	03
Terrace	04	155.37	1338.1	155.37	1338.1	8.65	04
Total		545.06	4637.7	545.06	4637.7	8.65	04

SCHEDULE OF JOINERY:

Room Name	Material	Quantity	Unit
Ground Floor	WOOD	10000	SQ.FT.
First Floor	WOOD	10000	SQ.FT.
Second Floor	WOOD	10000	SQ.FT.
Terrace	WOOD	10000	SQ.FT.

Unlabeled Table for Building A (SUMRAREN KERKETTA)

Room Name	Material	Quantity	Unit
Ground Floor	WOOD	10000	SQ.FT.
First Floor	WOOD	10000	SQ.FT.
Second Floor	WOOD	10000	SQ.FT.
Terrace	WOOD	10000	SQ.FT.

Room Name	Material	Quantity	Unit
Ground Floor	WOOD	10000	SQ.FT.
First Floor	WOOD	10000	SQ.FT.
Second Floor	WOOD	10000	SQ.FT.
Terrace	WOOD	10000	SQ.FT.

Color Index

Color	Description
Green	Grass Area
Yellow	Open Area
Red	Water Body

Parking Calculation

Room Name	Area (Sq. Ft.)	Parking No.
Ground Floor	209.45	10
First Floor	180.78	9
Second Floor	155.37	8
Terrace	155.37	8

Scale

Room Name	Scale
Ground Floor	1:100
First Floor	1:100
Second Floor	1:100
Terrace	1:100