

Project Title :SMT PRAMILA NARESH

NO.	DESCRIPTION	UNIT	QUANTITY	REMARKS
1	CEMENT	TONNES	10.00	
2	IRON RINGS	KGS	1000.00	
3	BRICKS	NO.	100000.00	
4	AGGREGATE	CUM	100.00	
5	PLASTER	SQ. M	1000.00	
6	PAINT	LITRES	100.00	
7	REINFORCEMENT	KGS	1000.00	
8	FORMWORK	SQ. M	1000.00	
9	CONCRETE	CUM	1000.00	
10	FOUNDATION	SQ. M	1000.00	
11	ROOFING	SQ. M	1000.00	
12	GLAZING	SQ. M	1000.00	
13	DOORS	NO.	1000.00	
14	WINDOWS	NO.	1000.00	
15	STAIRS	SQ. M	1000.00	
16	ELECTRICAL	SQ. M	1000.00	
17	MECHANICAL	SQ. M	1000.00	
18	PLUMBING	SQ. M	1000.00	
19	PAVING	SQ. M	1000.00	
20	LANDSCAPING	SQ. M	1000.00	
21	WATER SUPPLY	SQ. M	1000.00	
22	SEWERAGE	SQ. M	1000.00	
23	VENTILATION	SQ. M	1000.00	
24	INSULATION	SQ. M	1000.00	
25	AC	SQ. M	1000.00	
26	TELEVISION	SQ. M	1000.00	
27	INTERNET	SQ. M	1000.00	
28	SECURITY	SQ. M	1000.00	
29	LANDSCAPING	SQ. M	1000.00	
30	WATER SUPPLY	SQ. M	1000.00	
31	SEWERAGE	SQ. M	1000.00	
32	VENTILATION	SQ. M	1000.00	
33	INSULATION	SQ. M	1000.00	
34	AC	SQ. M	1000.00	
35	TELEVISION	SQ. M	1000.00	
36	INTERNET	SQ. M	1000.00	
37	SECURITY	SQ. M	1000.00	
38	LANDSCAPING	SQ. M	1000.00	
39	WATER SUPPLY	SQ. M	1000.00	
40	SEWERAGE	SQ. M	1000.00	
41	VENTILATION	SQ. M	1000.00	
42	INSULATION	SQ. M	1000.00	
43	AC	SQ. M	1000.00	
44	TELEVISION	SQ. M	1000.00	
45	INTERNET	SQ. M	1000.00	
46	SECURITY	SQ. M	1000.00	
47	LANDSCAPING	SQ. M	1000.00	
48	WATER SUPPLY	SQ. M	1000.00	
49	SEWERAGE	SQ. M	1000.00	
50	VENTILATION	SQ. M	1000.00	
51	INSULATION	SQ. M	1000.00	
52	AC	SQ. M	1000.00	
53	TELEVISION	SQ. M	1000.00	
54	INTERNET	SQ. M	1000.00	
55	SECURITY	SQ. M	1000.00	
56	LANDSCAPING	SQ. M	1000.00	
57	WATER SUPPLY	SQ. M	1000.00	
58	SEWERAGE	SQ. M	1000.00	
59	VENTILATION	SQ. M	1000.00	
60	INSULATION	SQ. M	1000.00	
61	AC	SQ. M	1000.00	
62	TELEVISION	SQ. M	1000.00	
63	INTERNET	SQ. M	1000.00	
64	SECURITY	SQ. M	1000.00	
65	LANDSCAPING	SQ. M	1000.00	
66	WATER SUPPLY	SQ. M	1000.00	
67	SEWERAGE	SQ. M	1000.00	
68	VENTILATION	SQ. M	1000.00	
69	INSULATION	SQ. M	1000.00	
70	AC	SQ. M	1000.00	
71	TELEVISION	SQ. M	1000.00	
72	INTERNET	SQ. M	1000.00	
73	SECURITY	SQ. M	1000.00	
74	LANDSCAPING	SQ. M	1000.00	
75	WATER SUPPLY	SQ. M	1000.00	
76	SEWERAGE	SQ. M	1000.00	
77	VENTILATION	SQ. M	1000.00	
78	INSULATION	SQ. M	1000.00	
79	AC	SQ. M	1000.00	
80	TELEVISION	SQ. M	1000.00	

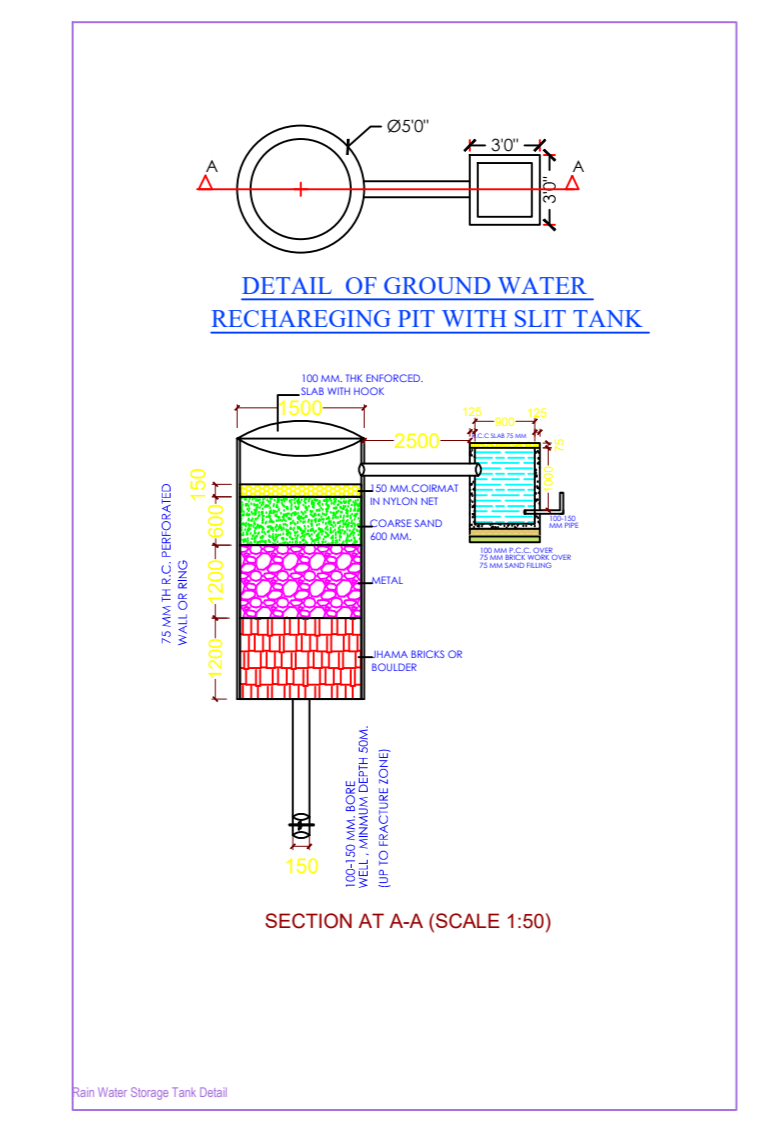
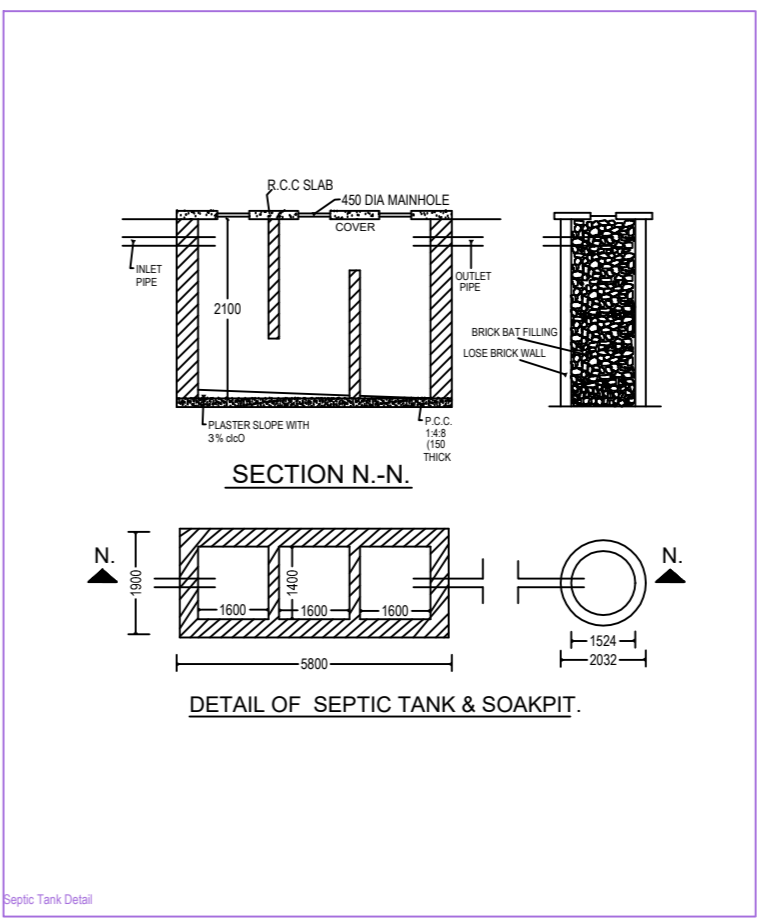
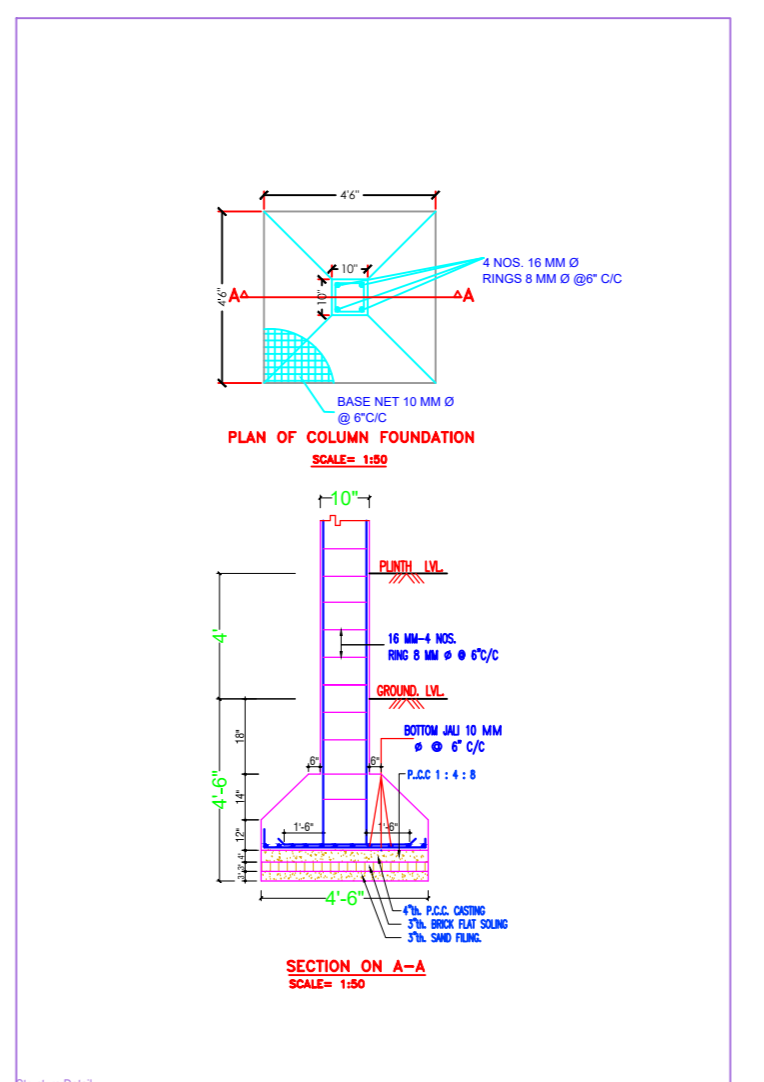
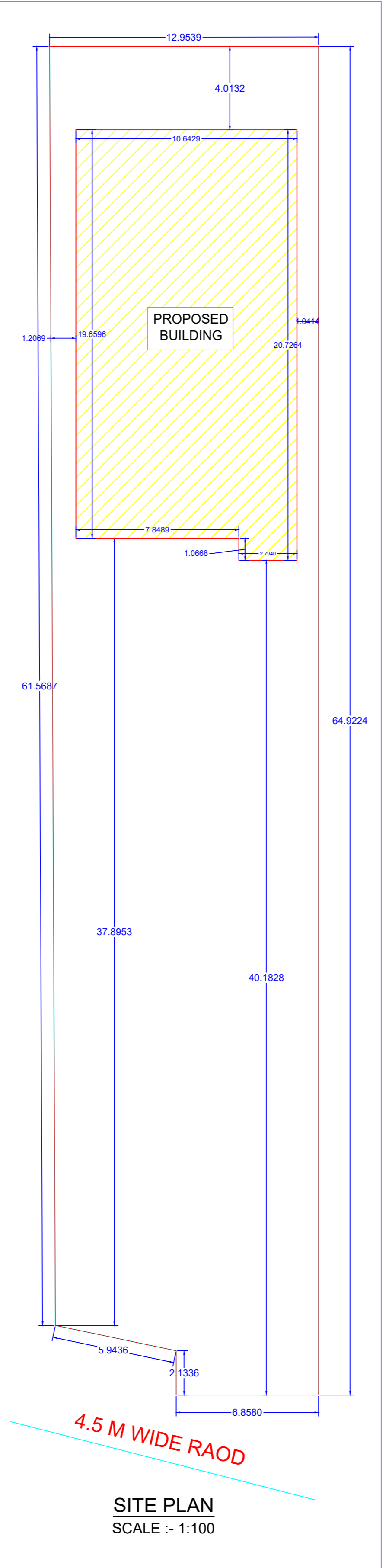
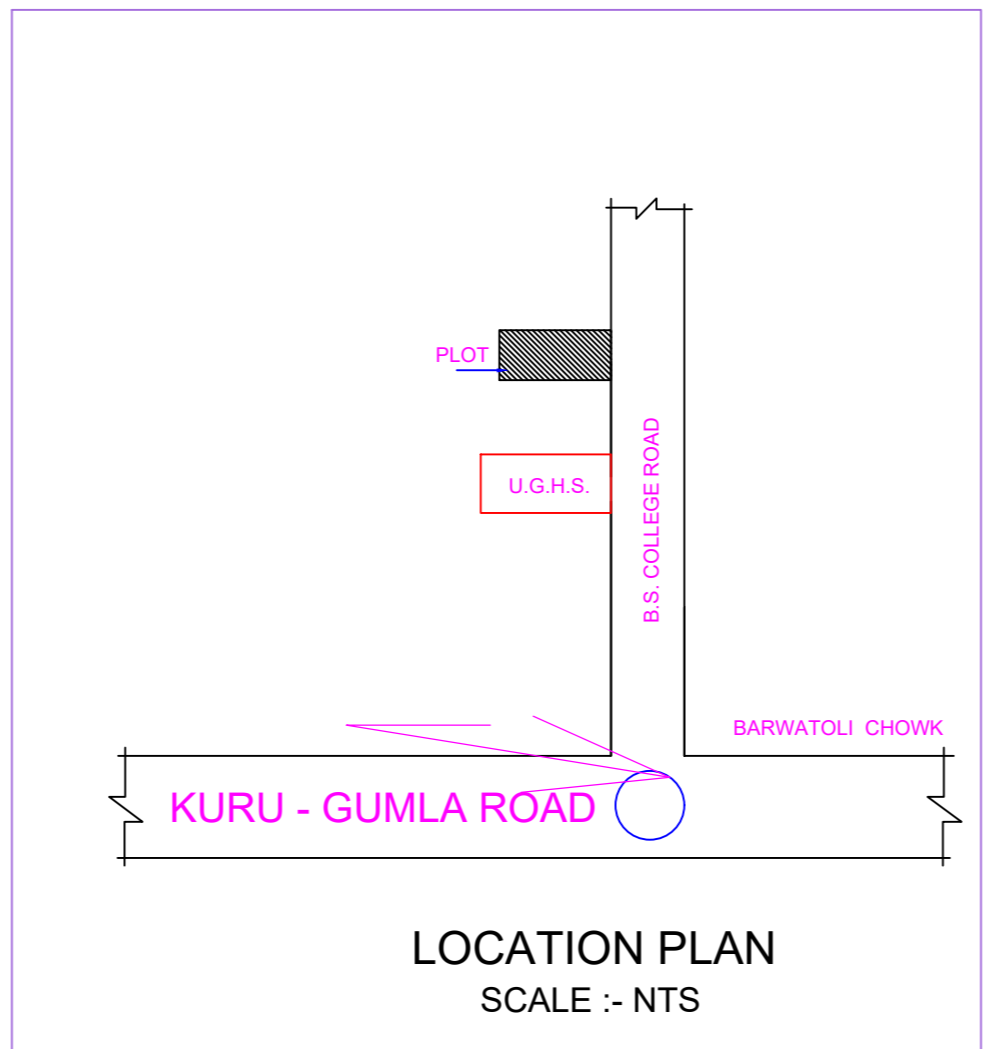
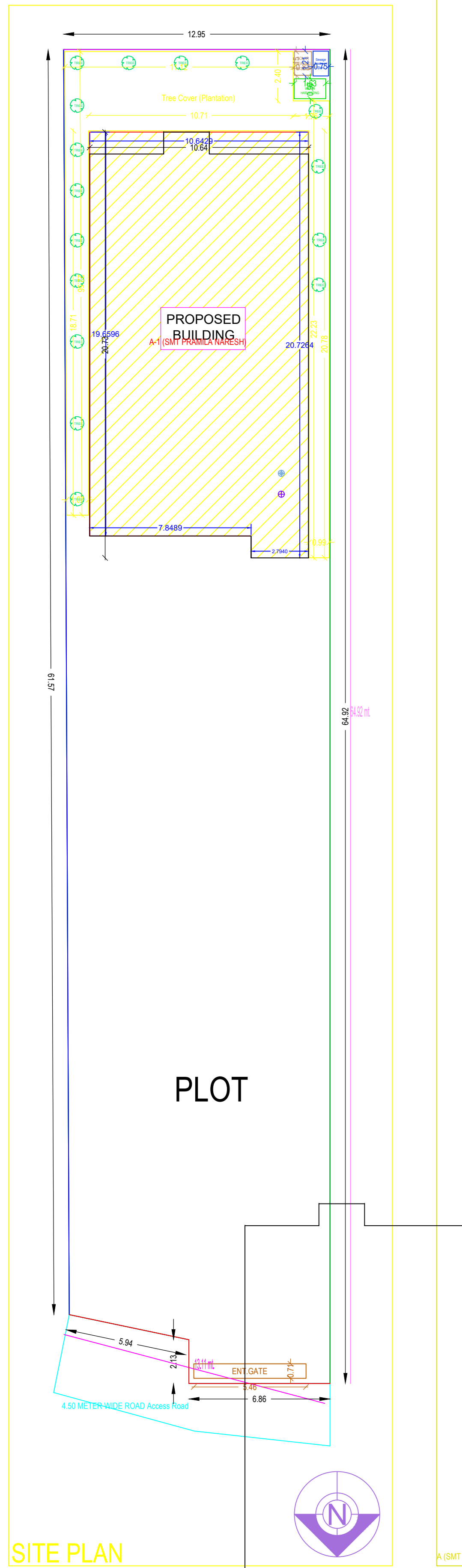

General notes

1. ALL DIMENSION ARE IN MILLIMETRES UNLESS OTHERWISE STATED.
2. NO DIMENSION IS TO BE SCALED OFF THE DRAWING.
3. DRAWINGS TO BE READ IN CONJUNCTION WITH ALL RELEVANT DRAWINGS & SPECIFICATIONS.
4. REFER WRITTEN DIMENSIONS ONLY.
5. DOORS AND WINDOW FRAME NOT TO BE FIXED ALONG WITH BRICK WORK.
6. INTERNAL PLASTER SHOULD BE 12MM THICK AND EXTERNAL PLASTER IS 25MM THICK.
7. FOUNDATION DEPTH UPTO GOOD SOIL.
8. CEMENT MORTAR OF MIX (1:4) FOR ENTIRE STRUCTURE AND PLASTER WORK.
9. SEPTIC TANK WILL BE FLUSHING SYSTEM.
10. ALL REINFORCEMENT SHALL BE OF FOR STEEL OF GRADE FY-415.
11. GRADE OF CONCRETE SHALL BE M-20

TYPE	WIDTH	HEIGHT	SILL LVL	DISCRIPTION
D	3'6"	7'0"	NILL	SINGLE SHUTTER FLUSH DOOR
D1	3'3"	7'0"	NILL	**
D2	3'0"	7'0"	NILL	**
D3	2'6"	7'0"	NILL	**
CG	5'0"	7'0"	NILL	STEEL CHANNEL GATE
W	5'0"	4'0"	3'0"	4 LEAF GLAZED WIND
W2	4'0"	4'0"	3'0"	**
W3	3'0"	4'0"	3'0"	**
V	2'0"	1'0"	8'0"	VENTILATOR

Schedule of area

AREA OF PLOT	815.51 SQM
AREA OF GROUND FLOOR	212.21 SQM
TOTAL BUILT UP AREA	424.42 SQM
% OF AREA COVERED	26.02
TOTAL F.A.R. ACHIEVED	0.52

PROPOSED RESIDENTIAL BUILDING PLAN OF SMT PRAMILA NARESH, W/O. NARESH KUMAR SAHU, PLOT NO. - 832, KHATA NO. 385 THANA NO. - 194, WARD NO. - 15, AREA - 20.25 DECIMAL, VILLAGE - SOBARN TOLL, THANA - LOHARDAGA, DIST. - LOHARDAGA, 835302, STATE - JHARKHAND

ISSUE ONLY FOR CLIENT

SCALE	DATE	SHEET NO.
1 : 100	01 OF 01	

CLIENT: ENGINEER / ARCHITECT

Building A (SMT PRAMILA NARESH)

Item Name	Unit	Quantity	Rate	Amount
CEMENT	TONNES	10.00	1000.00	10000.00
IRON RINGS	KGS	1000.00	10.00	10000.00
BRICKS	NO.	100000.00	10.00	1000000.00
AGGREGATE	CUM	100.00	100.00	10000.00
PLASTER	SQ. M	1000.00	10.00	10000.00
PAINT	LITRES	100.00	10.00	1000.00
REINFORCEMENT	KGS	1000.00	10.00	10000.00
FORMWORK	SQ. M	1000.00	10.00	10000.00
CONCRETE	CUM	1000.00	10.00	10000.00
FOUNDATION	SQ. M	1000.00	10.00	10000.00
ROOFING	SQ. M	1000.00	10.00	10000.00
GLAZING	SQ. M	1000.00	10.00	10000.00
DOORS	NO.	1000.00	10.00	10000.00
WINDOWS	NO.	1000.00	10.00	10000.00
STAIRS	SQ. M	1000.00	10.00	10000.00
ELECTRICAL	SQ. M	1000.00	10.00	10000.00
MECHANICAL	SQ. M	1000.00	10.00	10000.00
PLUMBING	SQ. M	1000.00	10.00	10000.00
PAVING	SQ. M	1000.00	10.00	10000.00
LANDSCAPING	SQ. M	1000.00	10.00	10000.00
WATER SUPPLY	SQ. M	1000.00	10.00	10000.00
SEWERAGE	SQ. M	1000.00	10.00	10000.00
VENTILATION	SQ. M	1000.00	10.00	10000.00
INSULATION	SQ. M	1000.00	10.00	10000.00
AC	SQ. M	1000.00	10.00	10000.00
TELEVISION	SQ. M	1000.00	10.00	10000.00
INTERNET	SQ. M	1000.00	10.00	10000.00
SECURITY	SQ. M	1000.00	10.00	10000.00