

# Project Title :SMT KOMAL KUMARI & SMT. RITA DEVI

AREA STATEMENT (LOHARDAGA NAGAR PARRISHAD)		VERSION NO. 1.0.11
Project No.	102/02	317.71
Project Name	PROPOSED RESIDENTIAL BUILDING PLAN	317.71
Client Name	SMT KOMAL KUMARI & SMT RITA DEVI	317.71
Plot Area	622.42	317.71
Proposed Floor Area	599.91	317.71
% of Covered Area	62.94%	317.71
Total F.A.R. Achieved	1.88	317.71
Plot Area	622.42	317.71
Proposed Floor Area	599.91	317.71
% of Covered Area	62.94%	317.71
Total F.A.R. Achieved	1.88	317.71
Plot Area	622.42	317.71
Proposed Floor Area	599.91	317.71
% of Covered Area	62.94%	317.71
Total F.A.R. Achieved	1.88	317.71

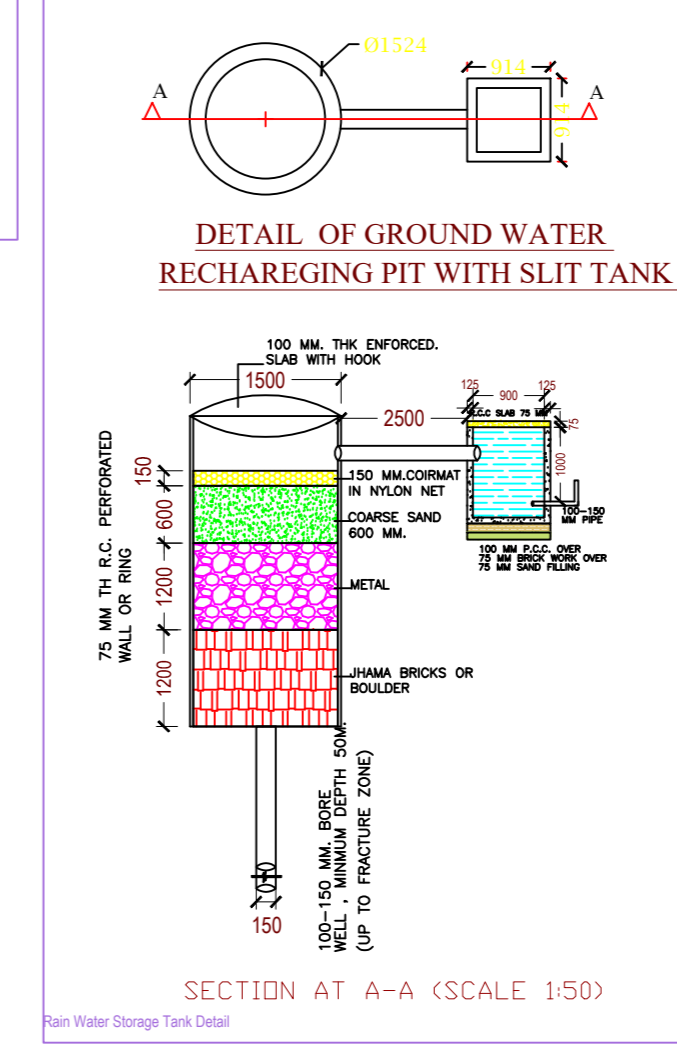
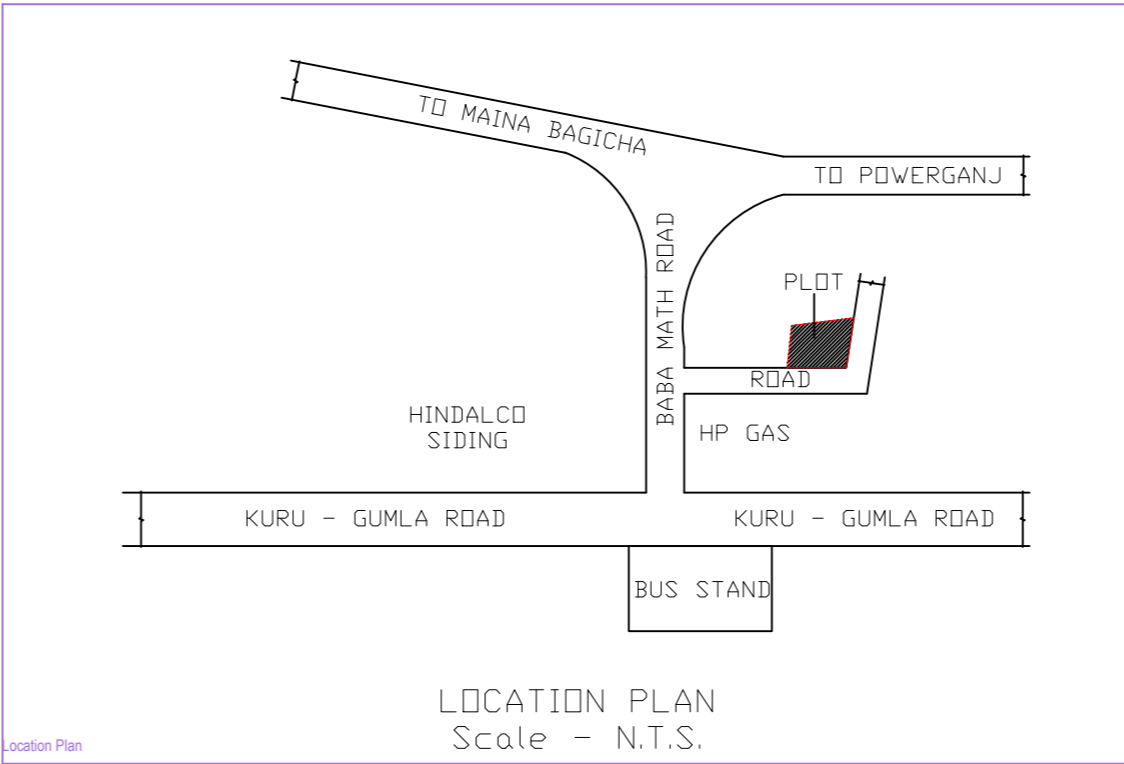
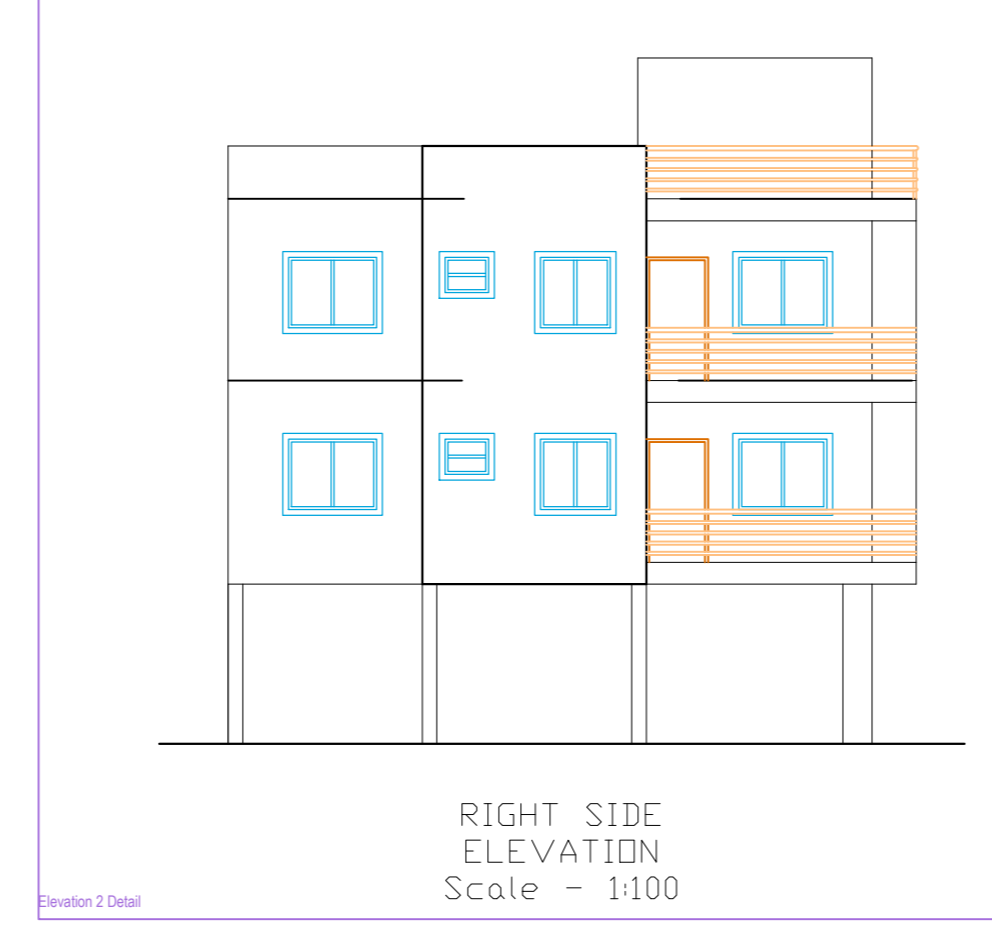
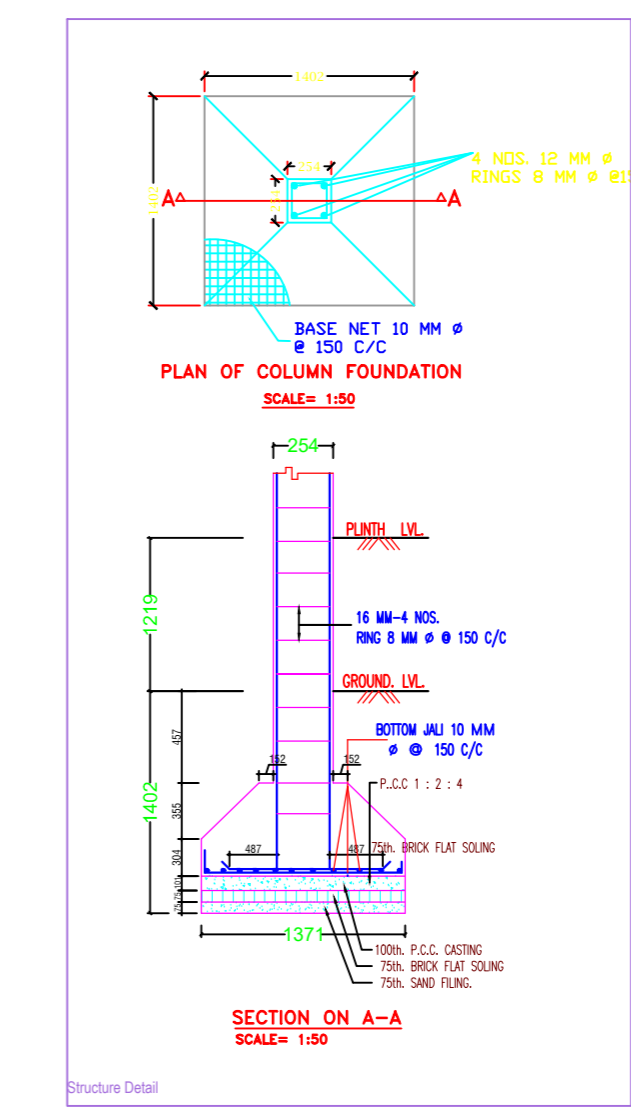
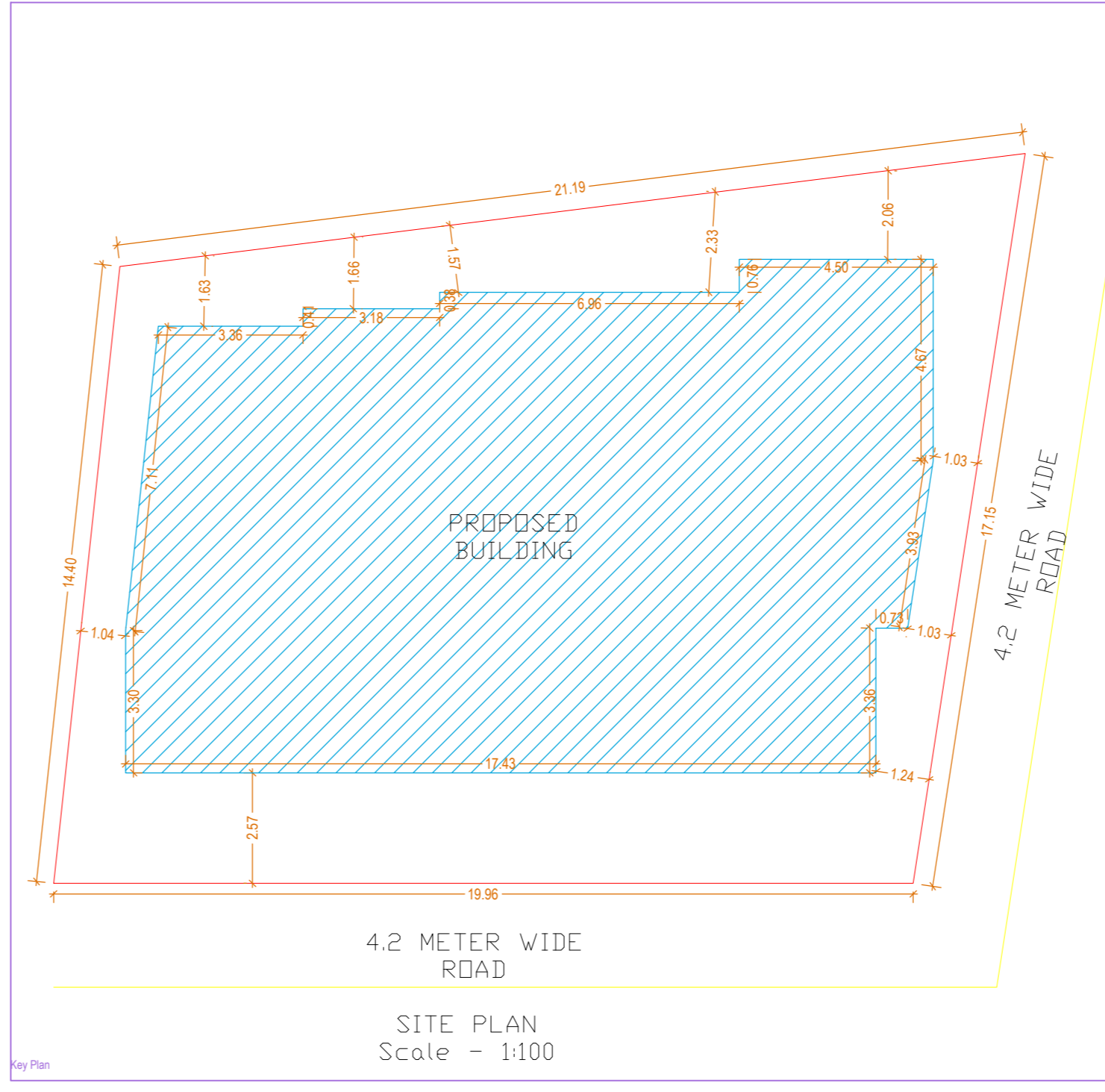
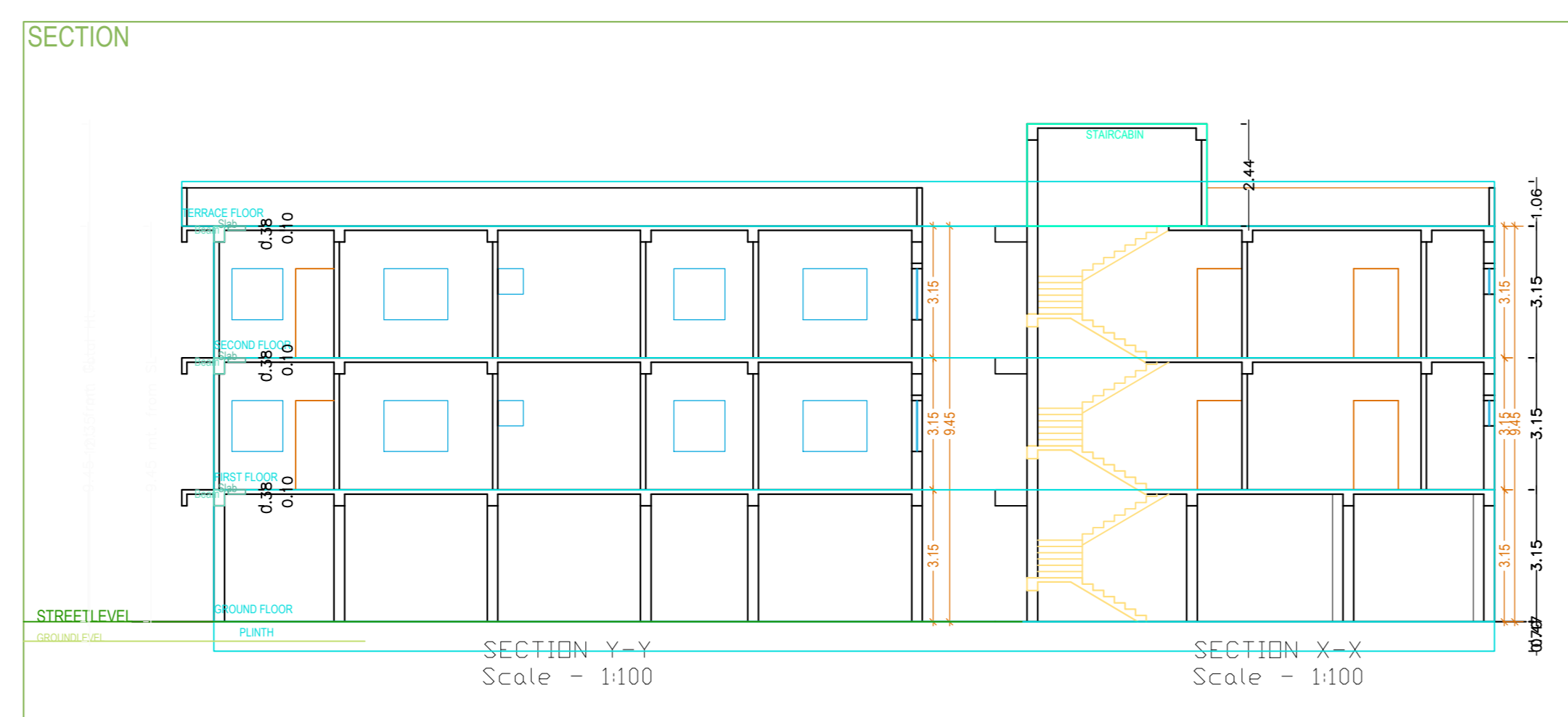

General notes	
1	ALL DIMENSION ARE IN MILLIMETRES UNLESS OTHERWISE STATED.
2	N/D DIMENSION IS TO BE SCALED OFF THE DRAWING.
3	DRAWINGS TO BE READ IN CONJUNCTION WITH ALL RELEVANT DRAWINGS & SPECIFICATIONS.
4	REFER WRITTEN DIMENSIONS ONLY.
5	DOORS AND WINDOW FRAME NOT TO BE FIXED ALONG WITH BRICK WORK.
6	INTERNAL PLASTER SHOULD BE 12MM THICK AND EXTERNAL PLASTER IS 25MM THICK.
7	FOUNDATION DEPTH UP TO GOOD SOIL.
8	CEMENT MORTAR OF MIX (1:4) FOR ENTIRE STRUCTURE AND PLASTER WORK.
9	SEPTIC TANK WILL BE FLUSHING SYSTEM.
10	ALL REINFORCEMENT SHALL BE OF FOR STEEL OF GRADE FY-415.
11	GRADE OF CONCRETE SHALL BE M-20

TYPE	WIDTH	HEIGHT	SILL LVL	DISCRPTION
D	1050	2100	NILL	SINGLE SHUTTER FULL SHOOK
DI	900	2100	NILL	---
W	1200	1200	900	4 LEAF GLAZED WIND
WI	900	1200	900	---
V	600	600	2400	VENTILATOR

PLOT AREA AT DEED	
PLOT AREA AT DEED	317.71 SQ.M.
AREA OF GROUND FLOOR	199.97 SQ.M.
AREA OF FIRST FLOOR	199.97 SQ.M.
AREA OF SECOND FLOOR	199.97 SQ.M.
TOTAL BUILD UP AREA	599.91 SQ.M.
% OF COVERED AREA	62.94%
TOTAL F.A.R. ACHIEVED	1.88

PROPOSED RESIDENTIAL BUILDING PLAN OF SMT KOMAL KUMARI W/O ASHISH KUMAR 2.SMT. RITA DEVI W/O LATE RAVINDRA PRASAD @ BHOLA PRASAD, R.S. PLOT NO. - 27/1072, KHATA NO. - 102, THANA NO. - 195, WARD NO. - 08/02, AREA-7.98 DECIMALS, VILLAGE - NADIA,THANA - LOHARDAGA, DIST - LOHARDAGA - 835302, STATE - JHARKHAND

ISSUE ONLY FOR CLIENT

SCALE	DATE	SHEET NO.
1 : 100		01 OF 01

CLIENT: \_\_\_\_\_ ENGINEER / ARCHITECT: \_\_\_\_\_

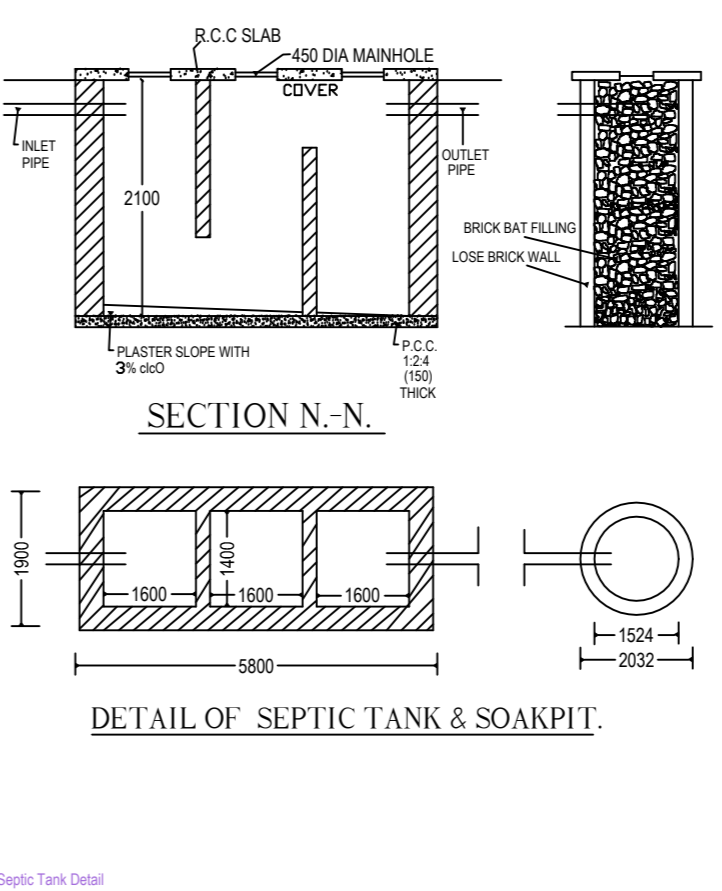
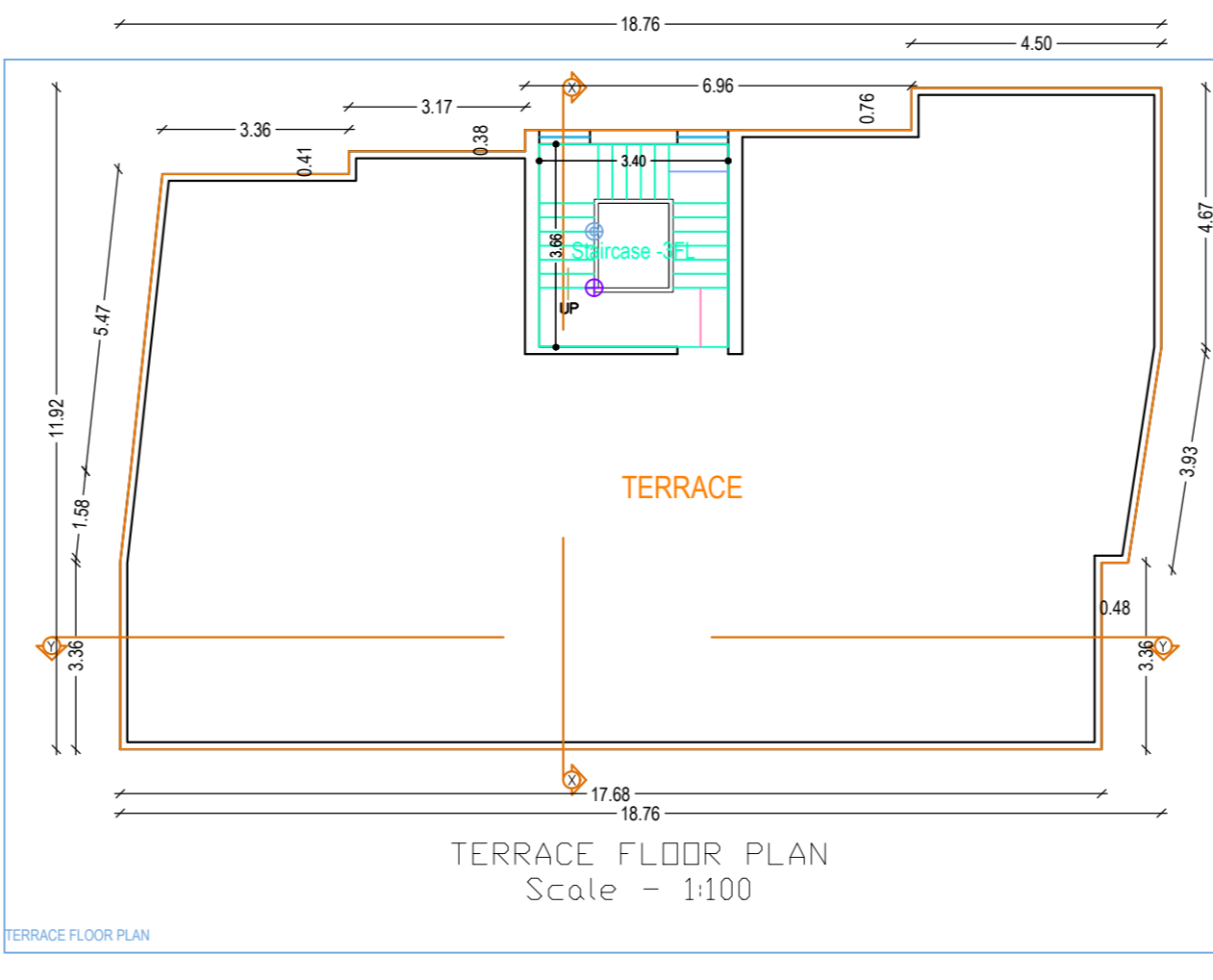
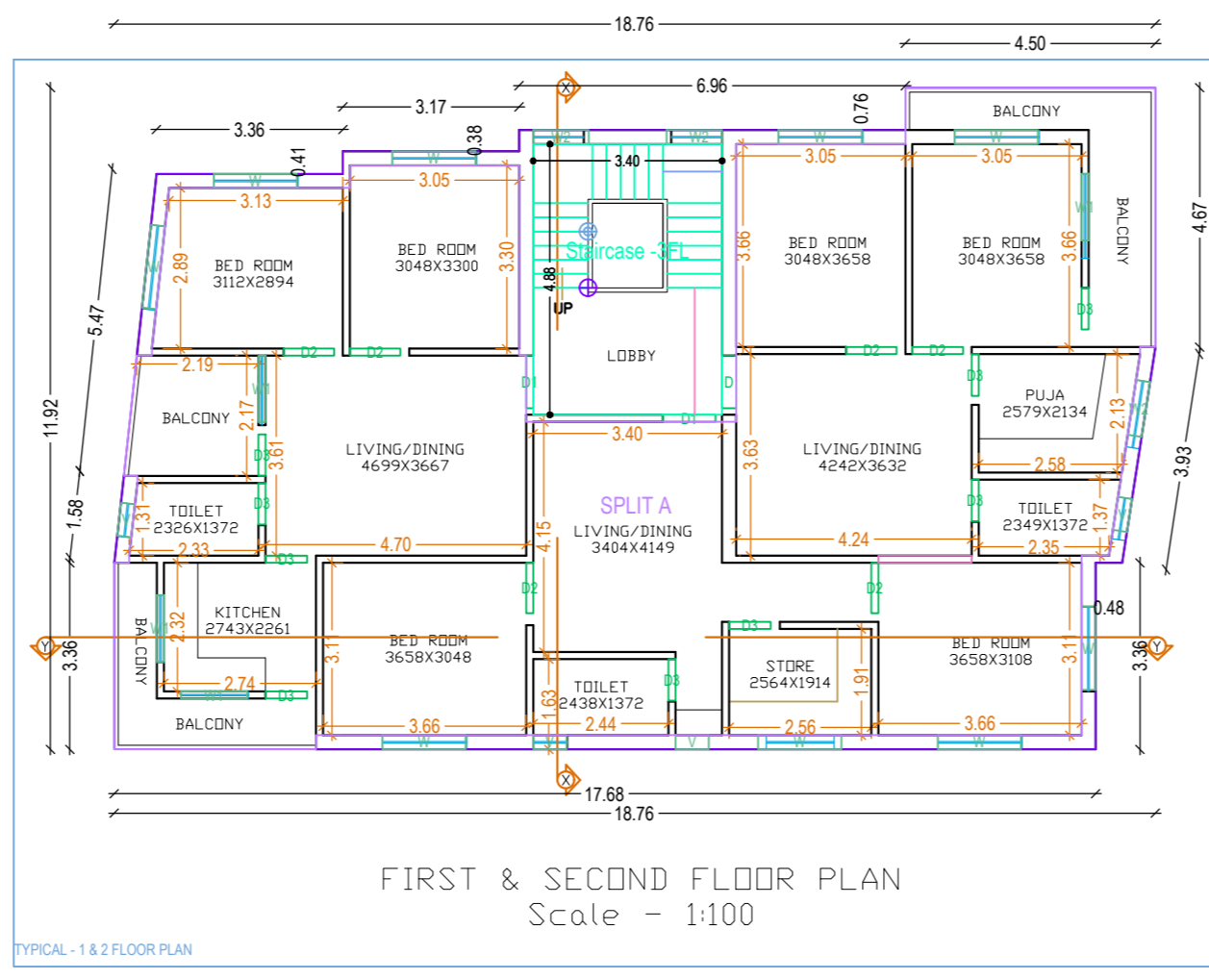
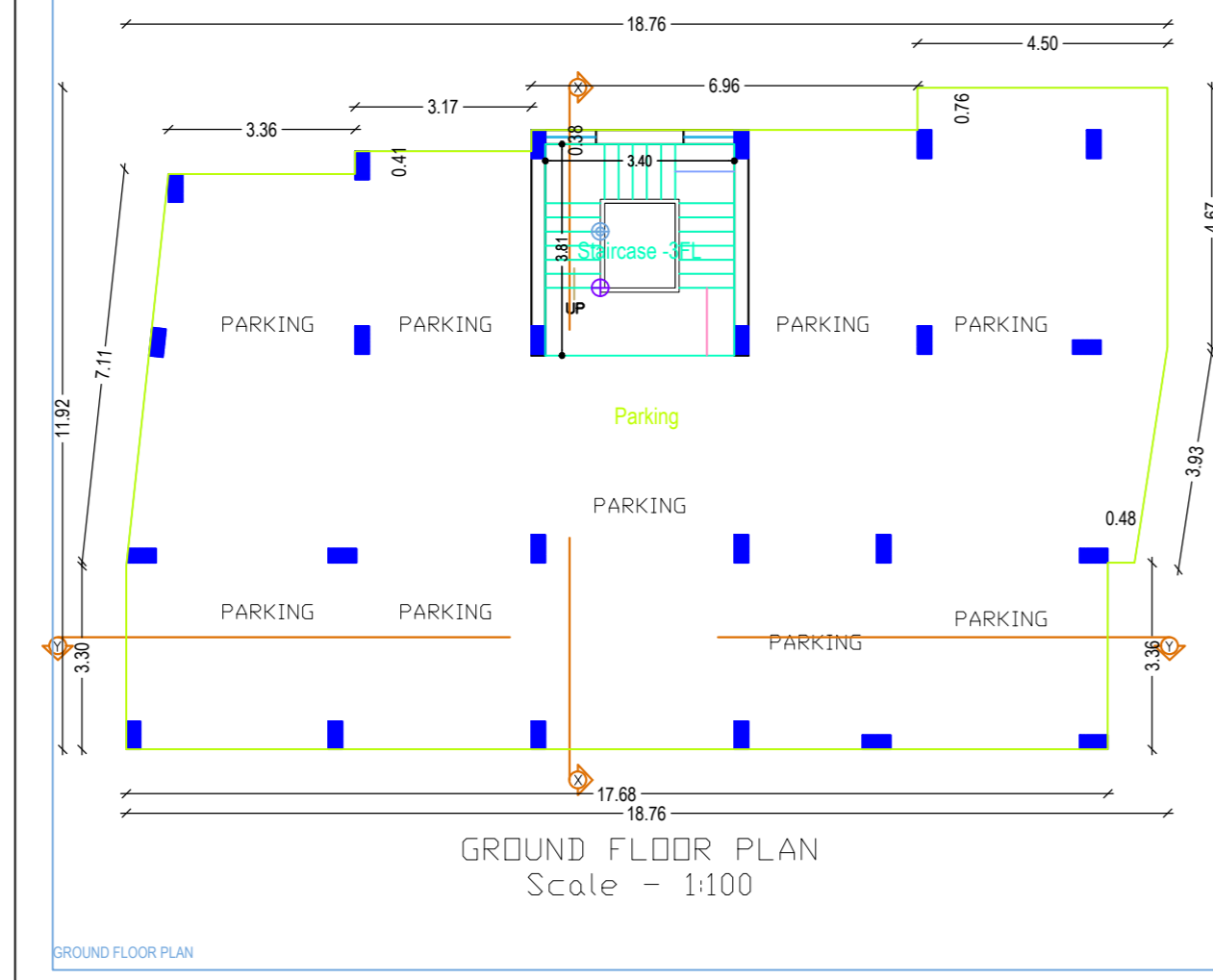
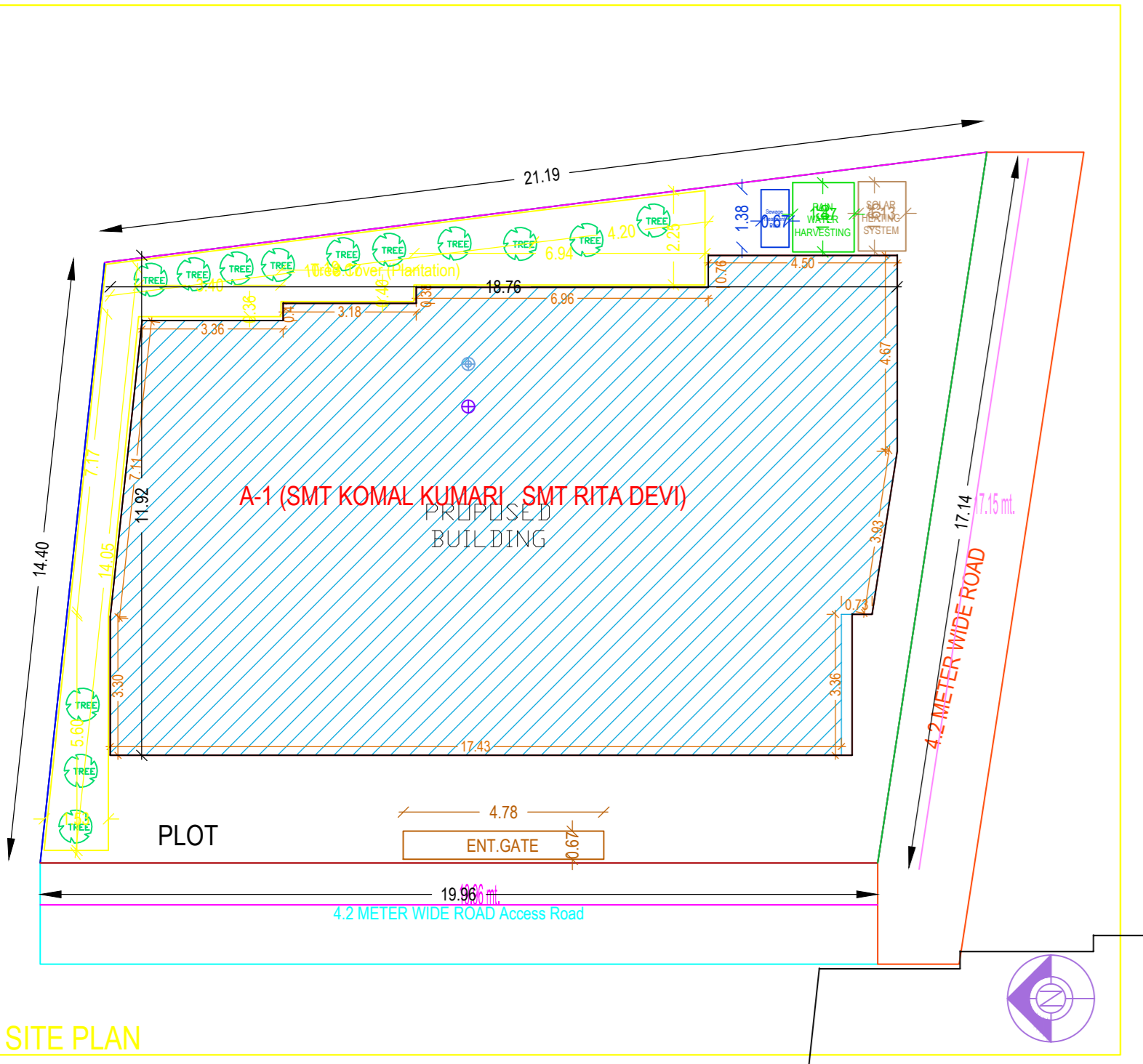

Floor Name	Total Built Up Area (Sq. Ft.)	Deductions Area (Sq. Ft.)	Proposed FAR Area (Sq. Ft.)	Add Area In FAR (Sq. Ft.)	Total FAR Area (Sq. Ft.)	Tent (No.)
Ground Floor	200.00	10.00	190.00	10.00	200.00	00
First Floor	200.00	10.00	190.00	10.00	200.00	01
Second Floor	200.00	10.00	190.00	10.00	200.00	01
Terrace Floor	200.00	10.00	190.00	10.00	200.00	00
Total	800.00	40.00	760.00	40.00	800.00	02

BEVELING NAME	NAME	LENGTH	HEIGHT	NO.	
A	SMT KOMAL KUMARI SMT RITA DEVI	03	0.75	213	18
B	SMT KOMAL KUMARI SMT RITA DEVI	02	0.91	213	12
C	SMT KOMAL KUMARI SMT RITA DEVI	01	0.95	213	04
D	SMT KOMAL KUMARI SMT RITA DEVI	0	0.95	213	02
TOP					36

BEVELING NAME	NAME	LENGTH	HEIGHT	NO.
V	SMT KOMAL KUMARI SMT RITA DEVI	0.00	1.00	08
W	SMT KOMAL KUMARI SMT RITA DEVI	1.00	2.70	06
WI	SMT KOMAL KUMARI SMT RITA DEVI	1.00	2.70	06
W	SMT KOMAL KUMARI SMT RITA DEVI	1.50	2.70	18
TOP				40

FLOOR	Name	Structure Type	Structure Area	Ground Area	No. of Rooms	No. of Tenement
TYPICAL	SPLIT A	FLAT	171.54	171.54	18	2
TOTAL			343.07	343.07	36	2