

SITE PLAN

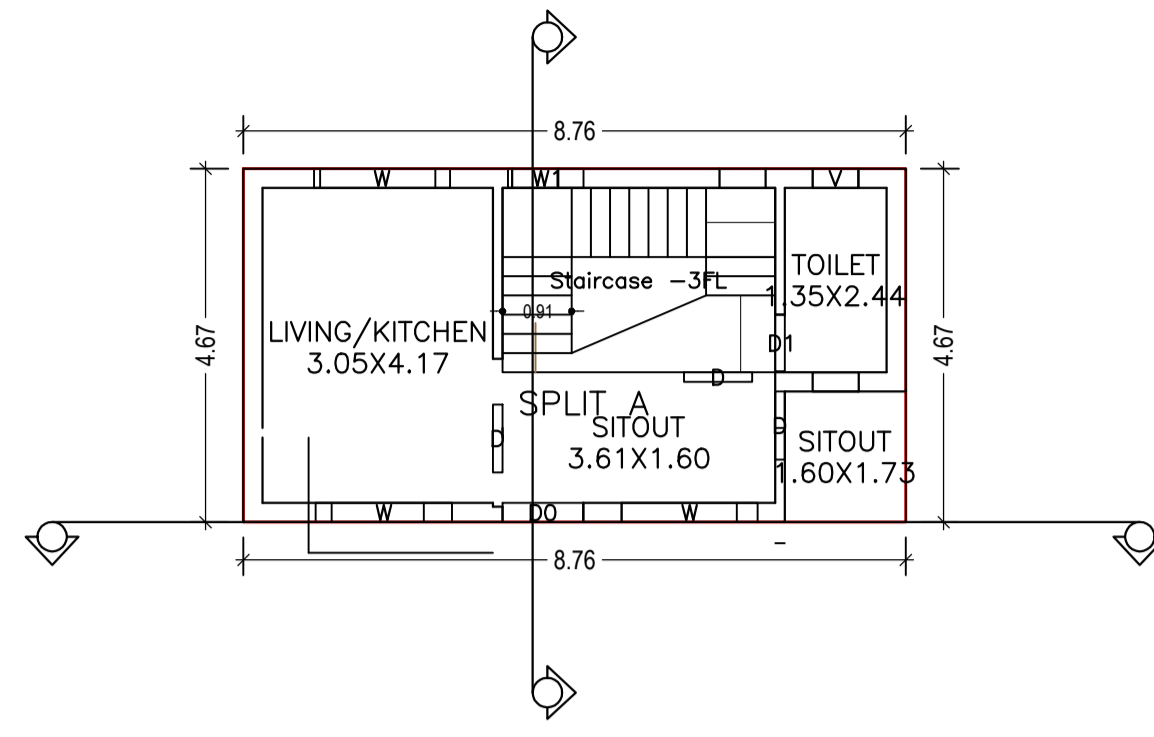

GROUND FLOOR PLAN (Proposed) (SCALE 1:100)

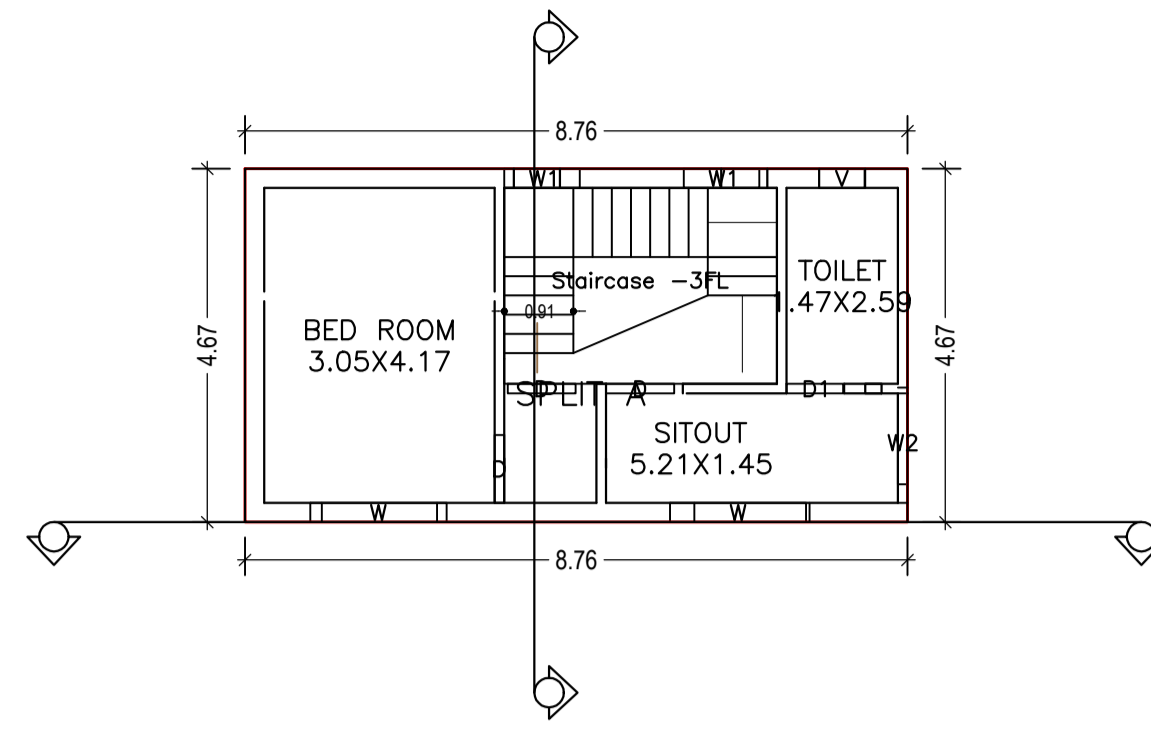

FIRST FLOOR PLAN (Proposed) (SCALE 1:100)

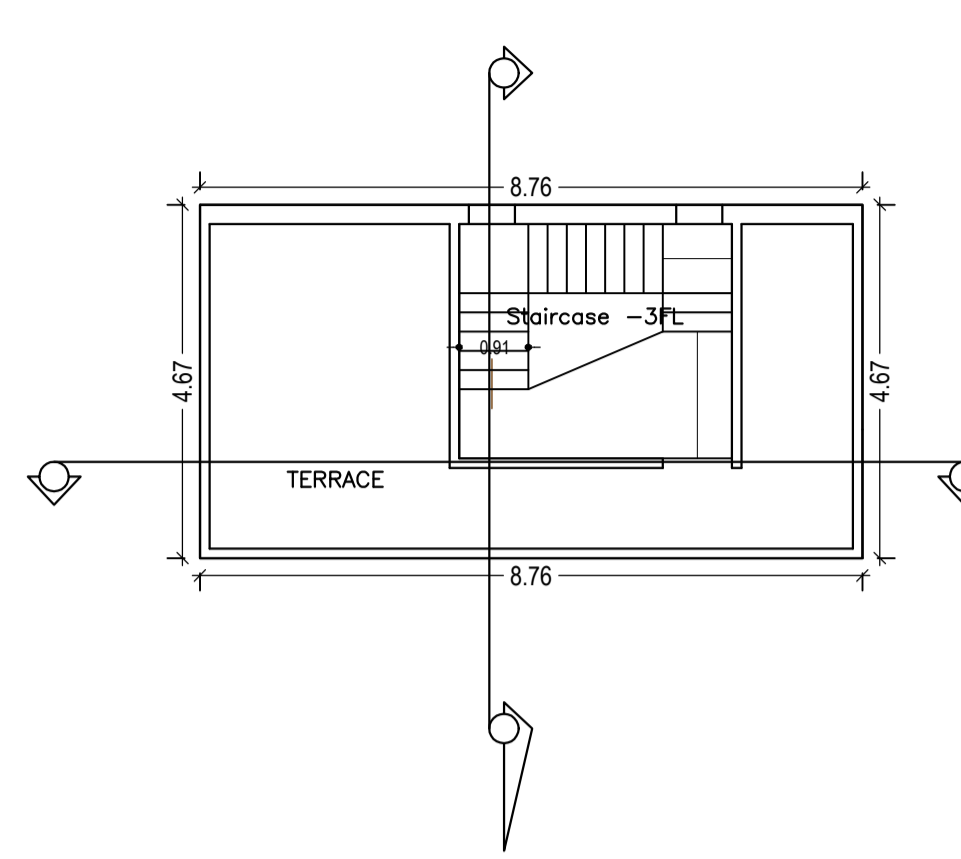

TERRACE FLOOR PLAN (SCALE 1:100)

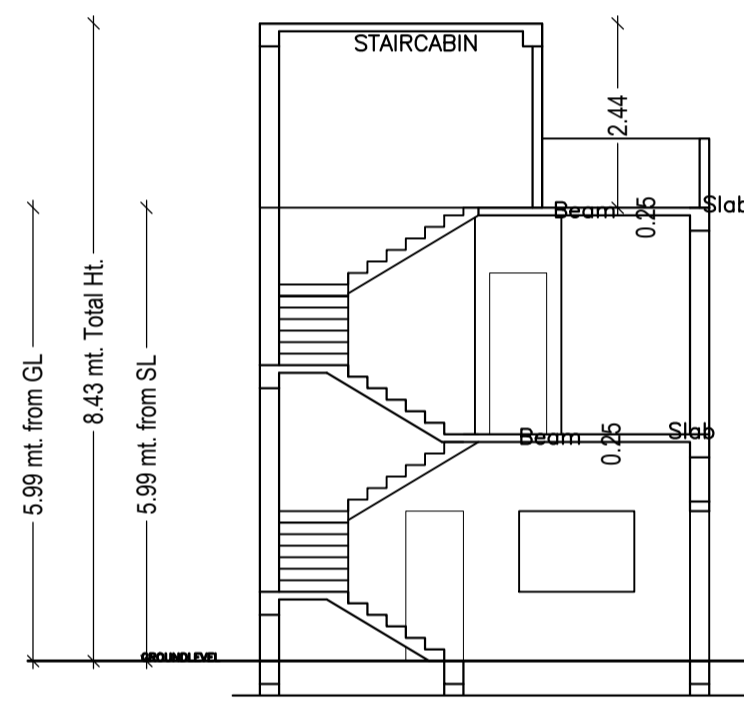

SECTION X-X Scale - 1:100

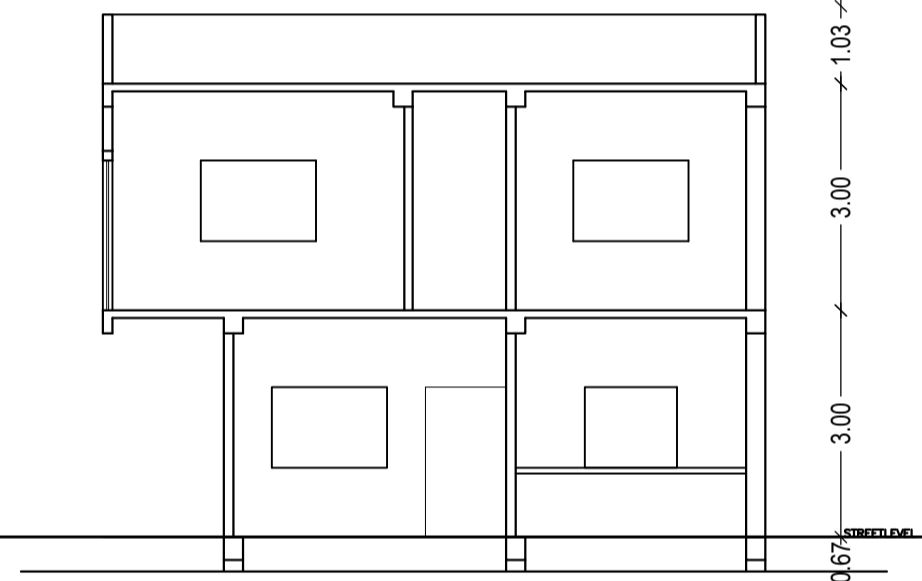

SECTION Y-Y Scale - 1:100

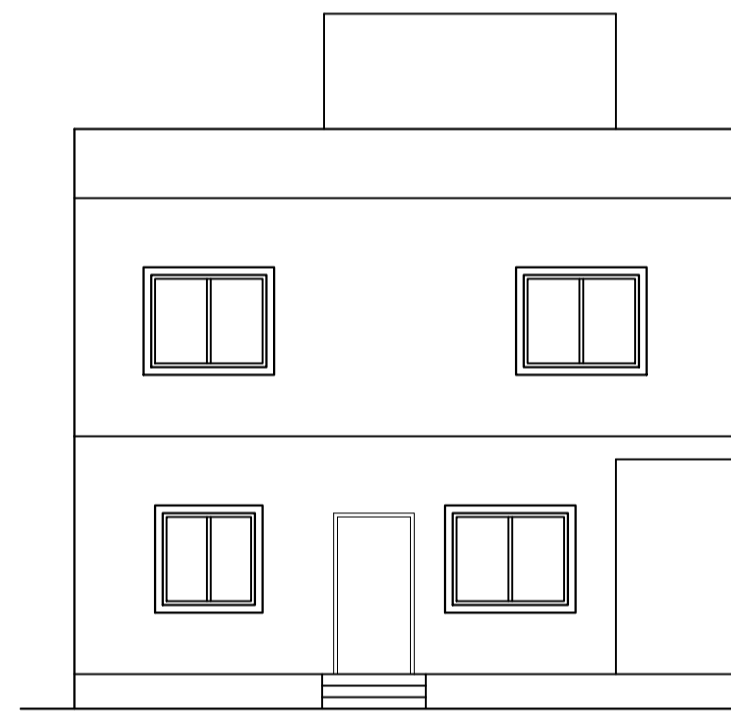

FRONT ELEVATION Scale - 1:100

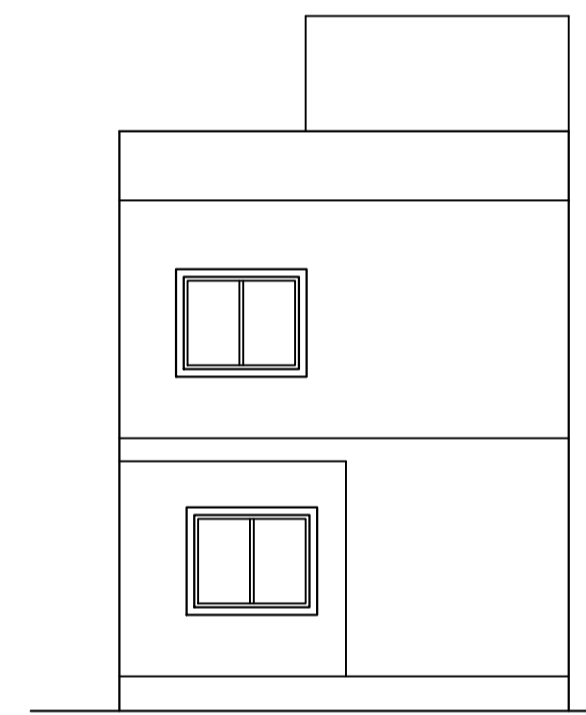

RIGHT SIDE ELEVATION Scale - 1:100

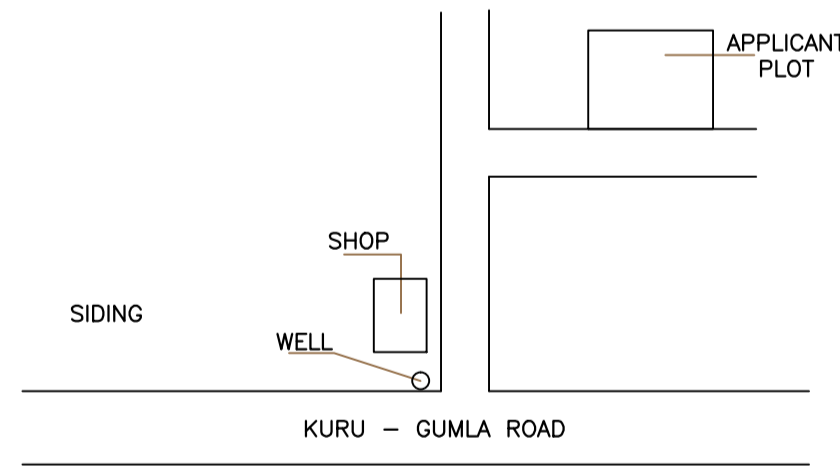

LOCATION PLAN Scale - 1:100

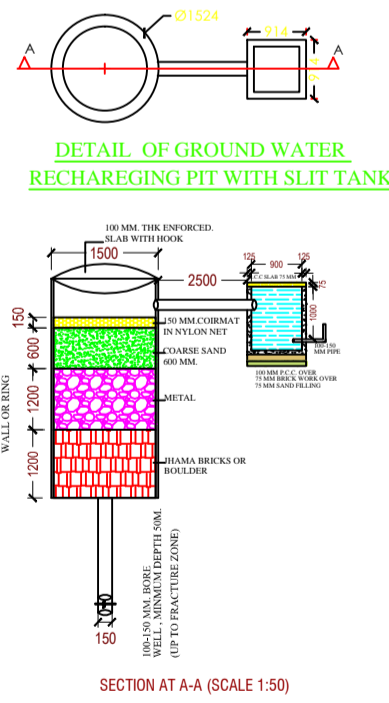

SECTION AT AA (SCALE 1:50)

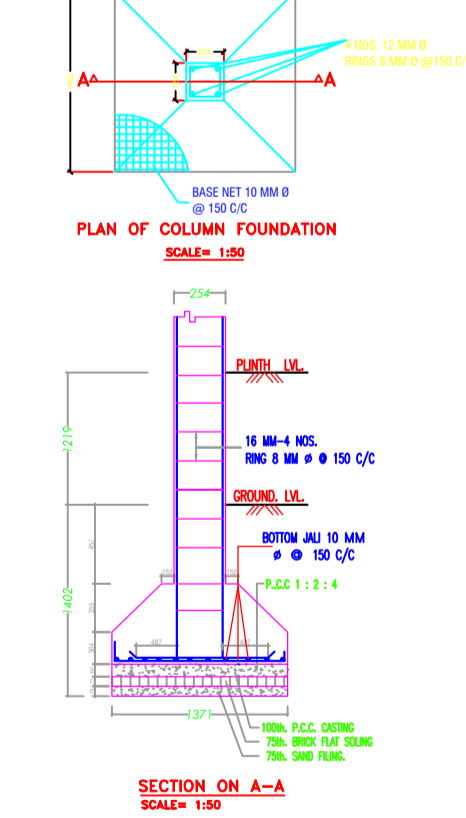

SECTION ON A-A SCALE 1:50

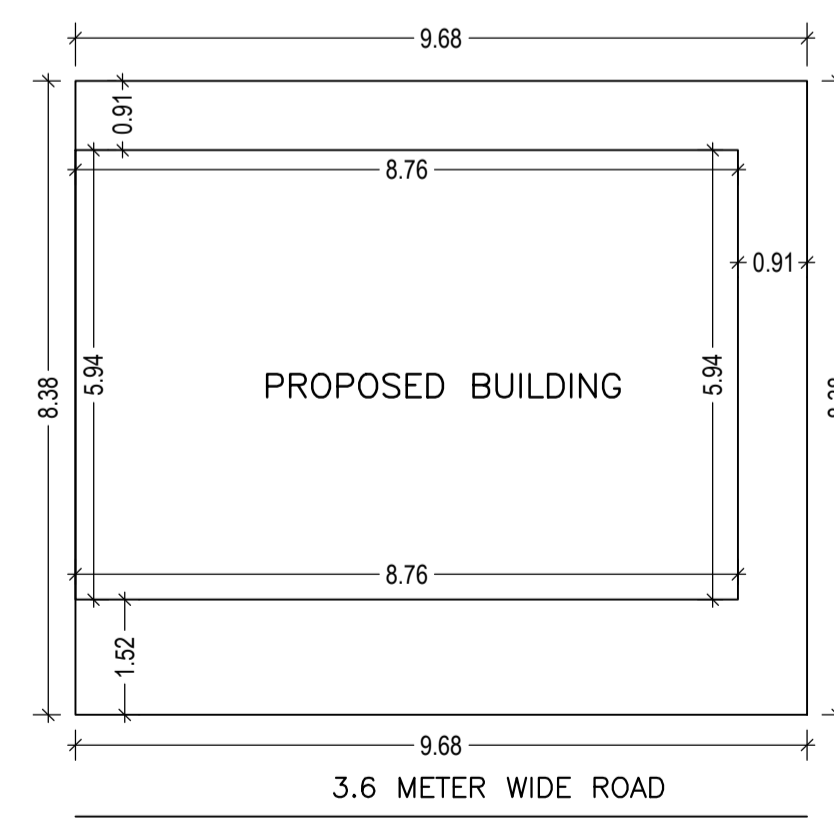

SITE PLAN Scale - 1:100

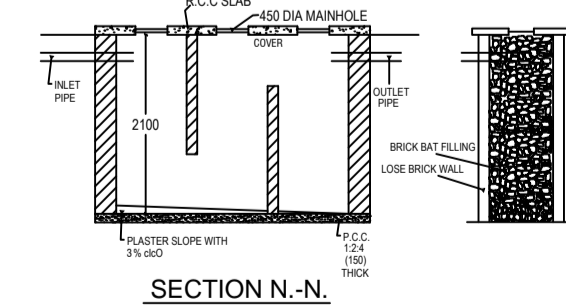

SECTION N-N

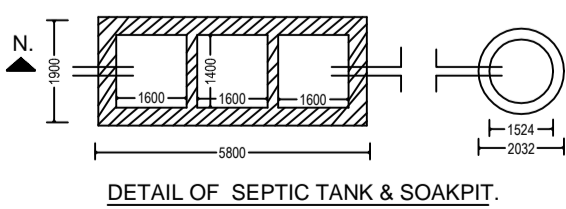

DETAIL OF SEPTIC TANK & SOAKPIT.

Building :A (SMT PRATIMA KUMARI)

Floor Name	Total Built Up Area (Sq.mt.)	Proposed FAR Area (Sq.mt.) Resi.	Total FAR Area (Sq.mt.)	Total Consumed Additional FAR Area (Sq.mt.)	Tnmt (No.)
Ground Floor	40.95	40.95	40.95	40.95	01
First Floor	40.95	40.95	40.95	40.95	00
Terrace Floor	0.00	0.00	0.00	0.00	00
Total:	81.90	81.90	81.90	81.90	01
Total Number of Same Buildings	1				
Total:	81.90	81.90	81.90	81.90	01

SCHEDULE OF DOOR:

BUILDING NAME	NAME	LENGTH	HEIGHT	NOS
A (SMT PRATIMA KUMARI)	D1	0.75	2.13	02
A (SMT PRATIMA KUMARI)	D	0.90	2.13	06
A (SMT PRATIMA KUMARI)	D0	1.07	2.13	01

SCHEDULE OF WINDOW/VENTILATION:

BUILDING NAME	NAME	LENGTH	HEIGHT	NOS
A (SMT PRATIMA KUMARI)	V	0.60	2.70	02
A (SMT PRATIMA KUMARI)	W1	1.00	2.70	03
A (SMT PRATIMA KUMARI)	W2	1.20	2.70	01
A (SMT PRATIMA KUMARI)	W	1.80	2.70	05

UnitBUA Table for Building :A (SMT PRATIMA KUMARI)

FLOOR	Name	UnitBUA Type	UnitBUA Area	Carpet Area	No. of Rooms	No. of Tenement
FIRST FLOOR PLAN	SPLIT A	FLAT	0.00	0.00	3	0
GROUND FLOOR PLAN	SPLIT A	FLAT	49.69	49.50	4	1
Total:	-	-	49.69	49.50	7	1

Proposal Basic Information	
Proposal File No.	LNP/BI/0034/W05/2019
Owner Name	PRATIMA KUMARI
Khata No	174
Plot No	140
Village Name	Nadia
Use	Residential
SubUse	Bungalow/ Dwelling / Non Apartment

AREA STATEMENT		VERSION NO. : 1.0.41
LOHARDAGA NAGAR PARISHAD		VERSION DATE: 29/04/2019
PROJECT DETAIL:		
Region: JHARKHAND URBAN LOCAL BODIES	Plot Use: Residential	
District: LOHARDAGA	Plot SubUse: Bungalow/ Dwelling / Non Apartment	
Authority: LOHARDAGA NAGAR PARISHAD	PlotNearby/ReligiousStructure: NA	
Inward No: LNP/BI/0034/W05/2019	Plot/SubPlot No: 140	
Application Type: General Proposal	North: Plot No. - 140	
Project Type: Building Permission	South: Plot No. - 140	
Nature of Development: New	East: Road Width - 3.6	
Location of Development Area: Old Area	West: Plot No. - 140	

AREA DETAILS:	SQ.MT.
AREA OF PLOT (Minimum)	(A) 81.12
Deduction for NetPlot Area	
Surrender Free of Cost	12.29
Total	12.29
NET AREA OF PLOT(Gross Plot Area - Deduction from Gross Plot area)	(A-Deductions) 68.83
Deduction for Balance Plot Area(from Gross Plot Area)	
Surrender Free of Cost	12.29
Common Plot	9.09
Total	21.38
BALANCE AREA OF PLOT(Net Plot Area - Recreational/Amenity space)	(A-Deductions) 59.73
PLOT AREA FOR COVERAGE(Net Plot Area)	(A-Deductions) 68.83
Plot Area for FAR (Net Plot Area + RoadWidening Area)	(A-Deductions) 81.12

COVERAGE CHECK	
Permissible Coverage area ( 70.00 % )	48.18
Proposed Coverage Area ( 59.50 % )	40.95
Total Prop. Coverage Area ( 59.5 % )	40.95
Balance coverage area ( 10.50 % )	7.23

FAR CHECK	
Perm. FAR Area ( 1.50 )	121.68
Total Perm. FAR area	121.68
Residential FAR	81.91
Proposed FAR Area	81.91
Total Proposed FAR Area	81.91
Consumed FAR (Factor)	1.01
Balance FAR Area	39.77

BUILT UP AREA CHECK	
Total Proposed BuiltUp Area	81.90
ARCHITECT (Regd)	ASHWINI KUMAR SAHU
ENGINEER (Regd)	
SUPERVISOR (Regd)	
OWNER (Regd)	PRATIMA KUMARI
DEVELOPMENT AUTHORITY	LOCAL BODY

COLOR INDEX	
PLOT BOUNDARY	Black
ABUTTING ROAD	Green
PROPOSED CONSTRUCTION	Red
COMMON PLOT	Yellow
ROAD WIDENING AREA	Blue
EXISTING (To be retained)	Orange
EXISTING (To be demolished)	Purple

Floor Name	Building Name		Total	
	Proposed Built Up Area (Sq.mt.)	Proposed FAR Area (Sq.mt.)	Total Proposed Built Up Area (Sq.mt.)	Total FAR Area (Sq.mt.)
Ground Floor	40.95	40.95	40.95	40.95
First Floor	40.95	40.95	40.95	40.95
Terrace Floor	0.00	0.00	0.00	0.00
Total:	81.90	81.90	81.90	81.90

Building Use/SUBUSE Details			
Building Name	Building Use	Building SubUse	Building Structure
A (SMT PRATIMA KUMARI)	Residential	Bungalow/ Dwelling / Non Apartment	Non-Highrise

FAR & Tenement Details (Table 4c-1)						
Building	No. of Same Bldg	Total Built Up Area (Sq.mt.)	Proposed FAR Area (Sq.mt.) Resi.	Total FAR Area (Sq.mt.)	Total Consumed Additional FAR Area (Sq.mt.)	Tnmt (No.)
A (SMT PRATIMA KUMARI)	1	81.90	81.90	81.90	81.90	01
Grand Total:	1	81.90	81.90	81.90	81.90	01

LTP NAME AND SIGNATURE	STRUCTURAL ENG'S NAME AND SIGNATURE	BUILDER NAME AND SIGNATURE	DIGITAL SIGNATURE
ASHWINI KUMAR SAHU LNP/ENG/0005/2017			