

Project Title :SRI GAUTAM KUMAR DEV

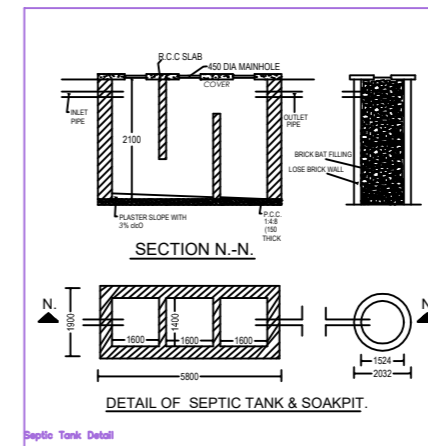
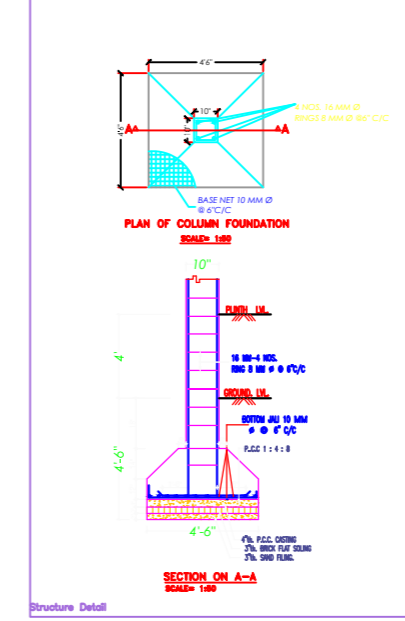
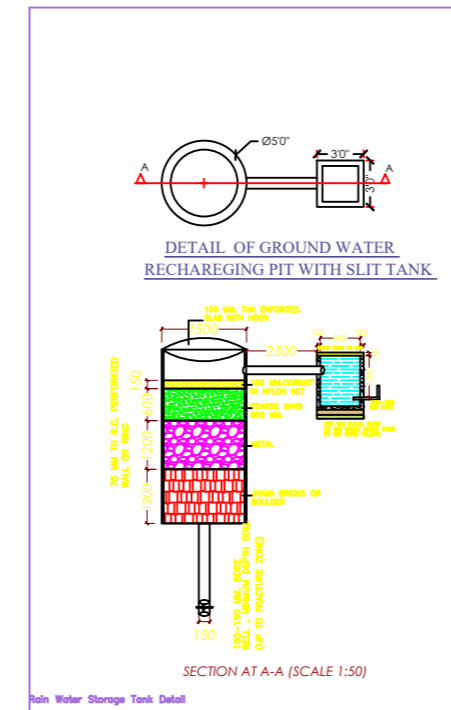
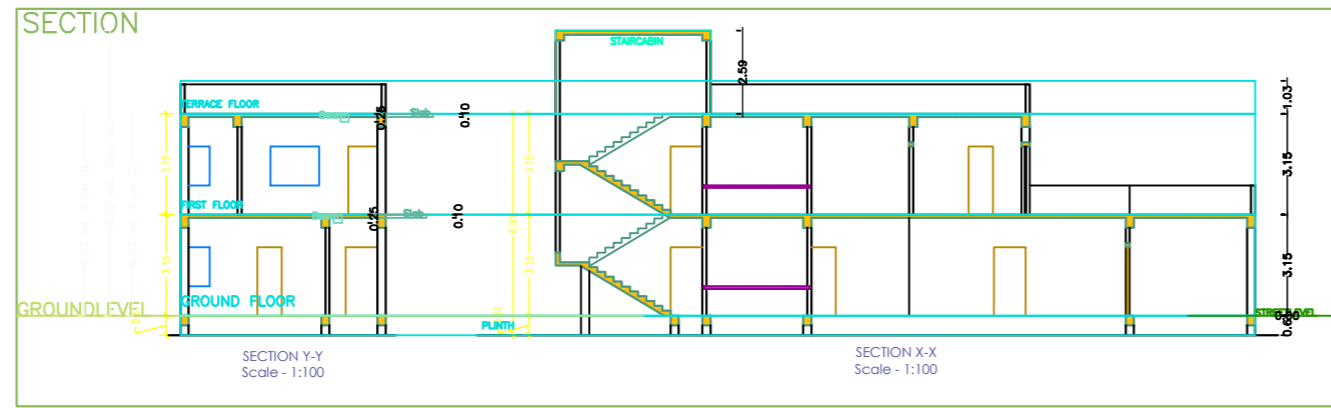
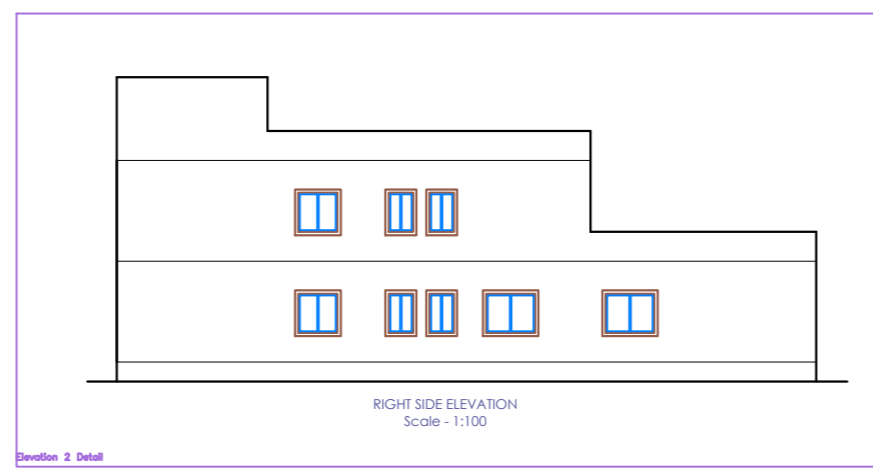
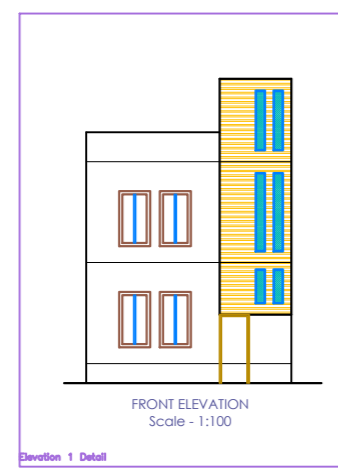

AREA STATEMENT - LOHARDAGA NAGAR PARISHAD		SESSION NO. 15.20
PROJECT DETAIL		SESSION DATE: 04/03/2018
Project No.	15/20/2018	Plot Size - Residential
Project Name	SRI GAUTAM KUMAR DEV	Plot Boundary - Residential (Dwelling / Non-Apartment)
Location	LOHARDAGA	Land Use Zone - R1B
Proposed Type	General Purpose	Building Foot Width
Project Type	Building Permission	Plot No.
Nature of Development	New	Reference Survey No/Survey No.
Location	LOHARDAGA	Thana No.
Plot Location	NA	Plotting No.
Project Name	SRI GAUTAM KUMAR DEV	Thana No.
Plot No.	15/20/2018	North
Plotting No.	15/20/2018	South
Plotting No.	15/20/2018	East
Plotting No.	15/20/2018	West

AREA STATEMENT		UNIT	AMT
Area of Plot (Minimum)		sq.m	258.47
Area of Plot (Maximum)		sq.m	258.47
Area of Plot (Average)		sq.m	258.47
Area of Plot (Minimum)		sq.m	258.47
Area of Plot (Maximum)		sq.m	258.47
Area of Plot (Average)		sq.m	258.47

COLOR INDEX	
Plot Boundary	Red
Proposed Work (Coverage Area)	Green
Existing (To be retained)	Blue
Existing (To be demolished)	Yellow

PARKING CALCULATION	
Plot Area	258.47
Proposed Area	15.38
Remaining Area	243.09

Building Wing	Road Name	Front Margin	Rear Margin	Side Margin	Setback Margin
A (SRI GAUTAM KUMAR DEV)	GUJALA - LOHARDAGA ROAD	4.23	7.84	0.00	0.01

Building	No. of Same Wing	Gross Built Up Area (Sq.m)	Deductions From Gross Built Up Area (Sq.m)	Total Built Up Area (Sq.m)	Proposed FAR Area (Sq.m)	Total FAR Area (Sq.m)	Tonn (No.)
A (SRI GAUTAM KUMAR DEV)	1	223.30	0.00	223.30	216.41	216.41	01
Total	1	223.30	0.00	223.30	216.41	216.41	01

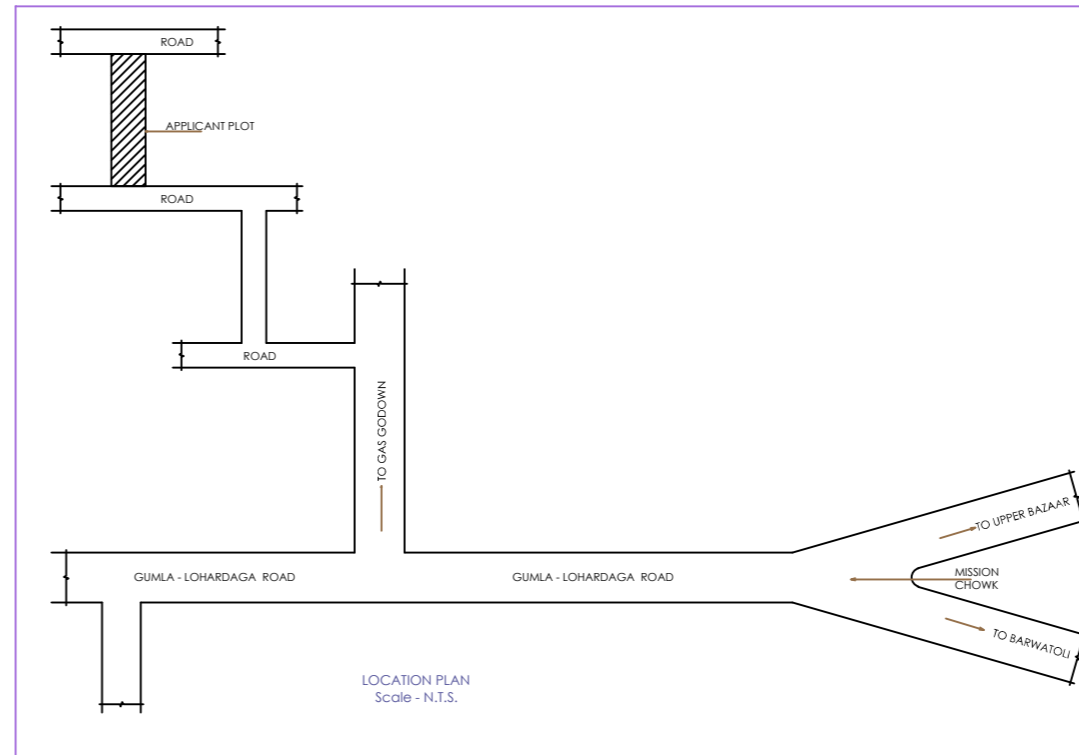
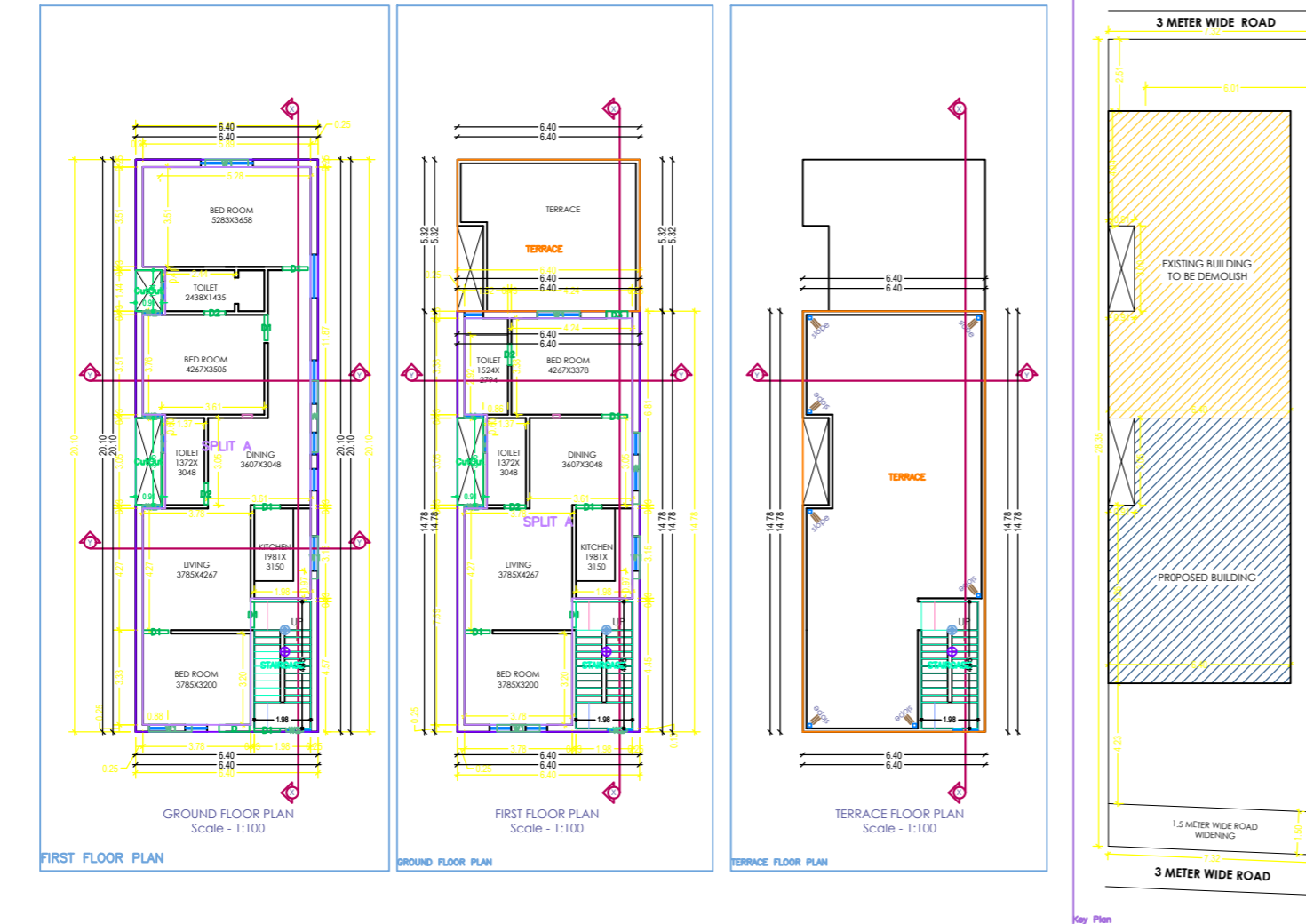
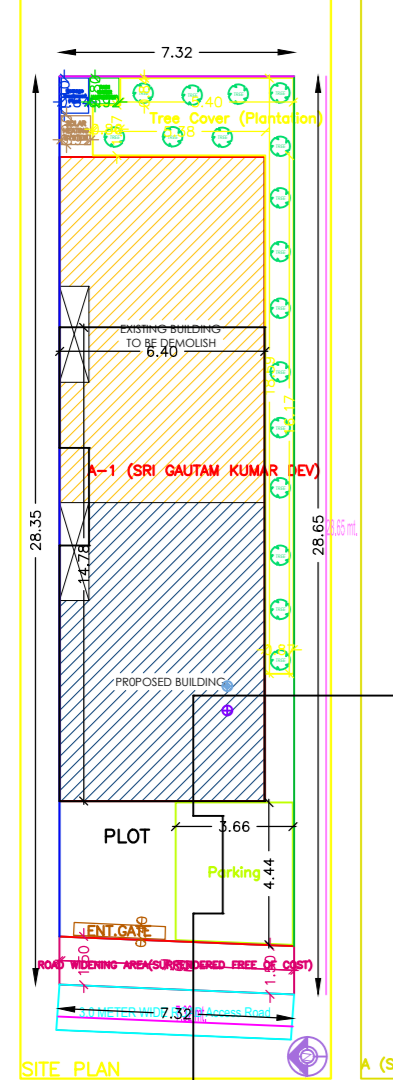

Floor Name	Gross Built Up Area	Deductions From Gross Built Up Area	Total Built Up Area (Sq.m)	Proposed FAR Area (Sq.m)	Total FAR Area (Sq.m)	Tonn (No.)
Ground Floor	223.30	0.00	223.30	216.41	216.41	01
First Floor	0.00	0.00	0.00	0.00	0.00	00
Terrace Floor	0.00	0.00	0.00	0.00	0.00	00
Total	223.30	0.00	223.30	216.41	216.41	01

Building Name	Name	Length	Height	No. of Joinery
A (SRI GAUTAM KUMAR DEV)	D0	0.75	2.13	01
A (SRI GAUTAM KUMAR DEV)	D1	0.75	2.13	04
A (SRI GAUTAM KUMAR DEV)	D2	0.90	2.13	10
A (SRI GAUTAM KUMAR DEV)	D3	1.07	2.13	01
Total	-	-	-	16

Building Name	Name	Length	Height	No. of Joinery
A (SRI GAUTAM KUMAR DEV)	W1	0.80	1.00	04
A (SRI GAUTAM KUMAR DEV)	W2	0.80	2.70	08
A (SRI GAUTAM KUMAR DEV)	W3	1.50	2.70	06
A (SRI GAUTAM KUMAR DEV)	W4	2.50	2.70	02
Total	-	-	-	18

Floor	Name	Area Type	Level/No.	Area (Sq.m)	No. of Rooms	No. of Joinery
GROUND FLOOR PLAN	SPLIT A	FLAT	114.32	174.25	4	1
1st	-	-	174.32	174.25	13	1